

UDC 539.3

THE APPLICATION OF JET GROUTING TECHNOLOGY TO REDUCE GROUND DEFORMATION OF CONSTRUCTION THE METRO LINE IN HO CHI MINH CITY

Nguyen Anh Tuan¹,

Tran Duc Chinh²,

Nguyen Thanh Dat³

¹*MSc. Transportation Engineering Faculty, University of Transport HCMC, Viet Nam*

²*DSc, Prof. (Viet Nam), Academician of ABU Academy, Ukraine*

³*PhD. Civil Engineering Faculty, University of Transport HCMC, Viet Nam*

Abstract: Slump and subsidence of surface deformation are concerned mostly in the process of construction of the Metro, especially in a weak soil environment, which affects the existence of buildings on the ground. This article introduces the application of Jet Grouting technology to reduce deformation of the surface when the Metro tunnel is constructed in the geological condition of the area of Ho Chi Minh City. Jet Grouting is the mixture of soil and cement (Soilcrete) created by the method of drilling the high grout pressure. Using Jet Grouting to strengthen the ground around the tunnel is seen as an effective solution to reduce surface subsidence.

Keywords: Surface subsidence, drilling the high grout pressure, Jet Grouting, Soilcrete, Metro.

1. Introduction

The underground transportation system is one of the optimal solutions to use effectively urban land. However, transportation system has become overloaded with increasing vehicular traffic in Ho Chi Minh City today, so some Metro lines are proposed to solve these traffic problems. Metro line No. 1 (Ben Thanh - Suoi Tien) - one of these Metro lines, has a total length of 19.7 km, including 2.6 km underground across the city which is constructed using a Tunnel Boring Machine (TBM)). And the remarkable advantage when constructing the tunnel by TBM is not to affect traffic and building constructions on the ground. However, underground construction using the TBM may cause surface settlement around a construction site. This is a major influence on major buildings which have high historical significance and importance to the city. Therefore, the maximum surface settlement should be less than 10 mm. As a result, the Metro construction must have solutions to mitigate surface settlement for the buildings. High pressure grout technology (Jet Grouting) is proposed to minimize surface settlement when the metro goes beneath.

2. Content

2.1. Introductions

Jet Grouting is a soil improvement technique using high pressure air, water jet, or cement slurry to erode in-situ soil and mix in-place the soil with cement slurry to create soil cement columns (soilcrete) which has higher strength than that of the in-situ soil.

Jet Grouting can create soilcrete blocks to ensure the intensity with different shapes through factors such as the speed of rotation, the speed of lifting, the layout, the arrangement of the drilled holes, etc., to serve specific purposes. The most common shape of Jet Grouting is mortar-column format created by rotating and lifting during the grout. The other complex structure can be formed by matching the basic structures mentioned above. These constructions make the blocks of soilcrete applied in geotechnic engineering to solve many problems. However, this method requires rigorously about designing technique and engineering in construction, or if there is any the error, it will lead to not qualify for the quality of soilcrete.

2.2. Jet Grouting technology in dealing with soft ground

Jet Grouting technology has been widely used in the world. However, this is still a new technology and not yet widely used in Vietnam. Today, in our country, Jet Grouting technology is applied in the irrigation sector, which brings certain success. In addition, the Jet Grouting is also used successfully to strengthen the concrete base, make diaphragm wall.

Although, Jet Grouting technology has some significant advantages, widespread application, and has been applied successfully in some projects in Viet Nam, there are still some difficulties to apply this technology widely in Viet Nam. One of the reasons is that there is not any procedure to instruct specifically, especially in Transportation and Building Sector. The majority of the projects is concentrated in the irrigation sector. There are two industrial standards of the irrigation sector: 14BC 82-1995 and 14BC 1-2004DD to make instruction in the injection of cement. To apply the Jet Grouting technology in Transportation and Building Sector, we need more specific study of this technology in Vietnam such as process of Designing Technology. Guidelines, construction, acceptance of work and so on.

- Construction of Jet Grouting

Construction process includes the following basic steps:

- + Step 1: Drilling hole must be drilled deeper than the design of Jet Grouting, a diameter of about 100-150 mm.
- + Step 2: Inserting the spray head down to the bottom of the hole
- + Step 3: Proceeding to grouting through nozzles with very great pressure, in order to expand the diameter holes drilled based on erosion. We start to grout either rotate or draw out the jackrod according to the rotation speed, the

speed of withdrawal pressure and flow pumps set before. This process includes the replacement and the mixture of the soil around the stucco sprayer.

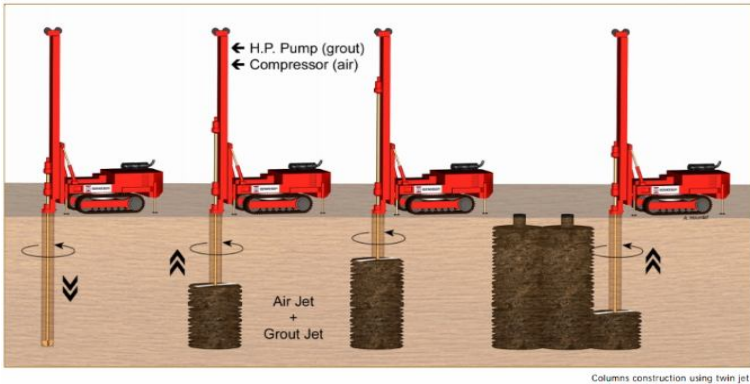

Fig. 1. The steps of the Jet Grouting construction

2.3. The application of Jet Grouting technology to reduce subsidence of surface deformation when constructing the metro tunnel in Ho Chi Minh City

2.3.1. Introduction of the Metro project No.1

Metro Line 1 (Ben Thanh – Suoi Tien) has the total length of 19.7 km including 17.1 km above surface and 2.6 km underground, passed through five Ho Chi Minh's districts: District 1, Binh Thanh District, District 2, District 9 and Thu Duc (in which there is a segment of Hanoi highway passing through Binh Duong Province).

Specifications and equipment of TBM tunnel

- Calculate on Km0 + 900 on the Metro line 1 (Ben Thanh - Suoi Tien).
- Drill U150 hole.
- Two vaults upper and below the bottom: the upper beam bottom is 16.444 m, the below beam bottom is 28.324 m.

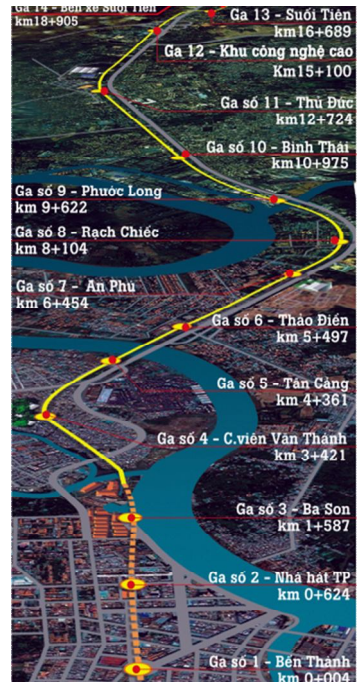

Fig. 2. Average map along Metro No. 1

- Tunnel cross-section: circular tunnel has a diameter of $D = 6.65$ m, thickness $d = 0.3$ m.

Table 1

Data of tunnel range and digging machine TBM of the Metro line 1 (the 2010 design document, QLDS-DT committee)

Components	Unit	Value
Inside Diameter	m	6.05
Outside diameter	m	6.65
The number of tunnel	Tunnel	2
Diameter of the TBM	m	6.79
Length of the TBM	m	7.8

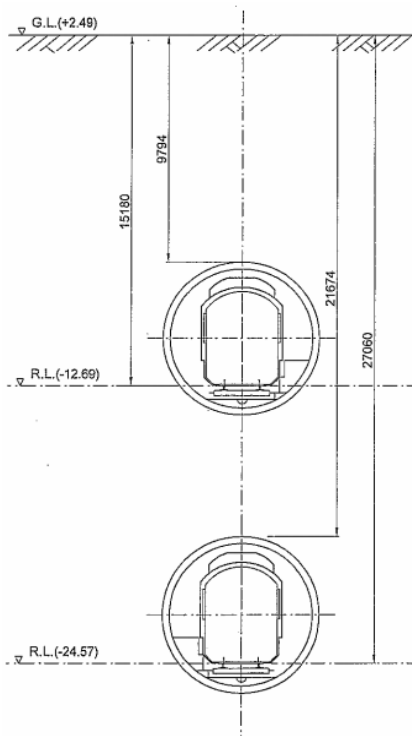

Fig. 3. Cross-section tunnel at Km0 + 900

Table 2

The table of soil general parameters Km0 + 900 (U150 drilled hole)

	Unit	Filled-up soil	Class 1: Soft Clayey Silt	Class 2: Silty Fine Sand Layer 1	Class 3: Sand Layer 2	Class 4: Sand Layer 3	Class 5: Hard Clayey Silt	Class 6: Dense Sand
Soil thickness	m	0.93	2.17	9.2	6.7	13.5	16.3	1.65
Natural Density γ	kN/m ³	19	17.5	19.5	20	19	21	20.5
Saturated Density γ_{sat}	kN/m ³	20.3	19.72	20.6	20.3	20.1	21.1	20.8
Young modulus E_{ref}	kN/m ²	5000	5000	15000	40000	55000	180000	95000
Poisson ratio ν		0.35	0.35	0.3	0.3	0.3	0.3	0.3
Cohesion c	kN/m ²	12	12	0	0	0	300	0
Friction angle ϕ	degree	0	0	26	31	33	0	36
Dilation angle ψ	degree	0	0	0	0	0	0	0
Horizontal permeability K_x	m/day	1.728e-2	4.32e-3	3.024e-2	1.728e-2	1.296e-2	1.296e-3	6.48e-3
Vertical permeability K_y	m/day	1.728e-2	4.32e-3	3.024e-2	1.728e-2	1.296e-2	1.296e-3	6.48e-3

2.3.2. Jet Grouting applications in dealing with soft soil when constructing the tunnel on Metro line 1

Building constructions on the ground where the metro tunnel goes through should be required that the maximum settlement of structure should be the allowable limit (maximum = 10 mm). The author proposes to limit the settlement by using Jet Grouting. The alternative using mortar injection is proposed to use the frame surrounding the 2 – concentricity tunnel.

2.3.3. The analysis of deformation of soils around the tunnel before and after treated by Jet Grouting method

In this analysis, surface settlement is analyzed in the following cases:

- + Without Jet Grouting.
- + After processing by Jet Grouting methods.

Applying Finite Element Method is the major approach to calculate the surface subsidence.

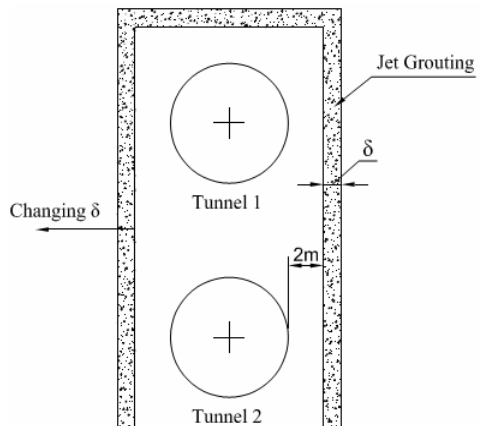

Fig. 4. Alternative using mortar of Jet Grouting at Km0 + 900 on the Metro

2.3.3.1. Calculating the surface subsidence without Jet Grouting:

The Plaxis 2D software is used to modelize the analysis the surface settlement varying with the characteristics of soilcrete based on volume V_L . The input parameters are introduced in the section “**Jet Grouting applications in dealing with soft soil when constructing the tunnel on Metro line 1**”. With the chosen model calculated according to Mohr-Coulomb model, for drainage problems (Drain), with mostly core material of sand, soil layers, without considering types of load effects on the surface.

Soil settlement value depends on the value V_L depending on each type of land values which can be changed in the range from 0.3% to 5.0%. Results of calculation of the soil settlement below are corresponding to the change in the value V_L from 0.5%-3.0%. The value V_L for sand soil in the case that the construction methods are guaranteed for good quality insurance and have no trouble to alter the volume loss so the value V_L is in the range 0.3%-0.8%. However, to calculate for catastrophic failures, as well as forcing to replace the blade in the training process, the value V_L is taken to 3.0% to research. Soil settlement value results are shown in table 4.

Table 3

Parameters of Jet Grouting used for computational models

	Unit	Value
Thickness δ	m	Changed
Unsaturated Density γ_{unsat}	KN/m ³	20
Saturated Density γ_{sat}	KN/m ³	22
Young modulus E_{Ref}	KN/m ²	Change
Possions ratio ν		0.2
Cohesion c	KN/m ²	100
The friction angle ϕ	speed	30
Dilation angle ψ	speed	0
Horizontal permeability K_x	m/day	0.5
Vertical permeability K_y	m/day	0.5

Table 4

Soil settlement value changes depending on the % of value V_L

V_L (%)	S (mm)	
	Surface	S_{max}
0.5	7.42	14.31
1.0	22.41	36.12
1.5	39.82	58.92
2.0	57.39	82.80
2.5	77.27	108.68
3.0	99.46	134.69

From the results of calculating soil settlement value by Finite Element Method by using the Plaxis 2D software v8.5, the calculation results are aggregated from the input data of geology and tunnel shell structure shows that the biggest soil settlement is not in the surface while it is located in the shell structure around the tunnel. Figure 5 and figure 6 demonstrate the distribution of subsidence of surface deformation around the background surrounding the tunnel construction when constructing the tunnels above and below of the Metro No. 1 line in the case that the value V_L is 1.5% and V_L is 3.0%.

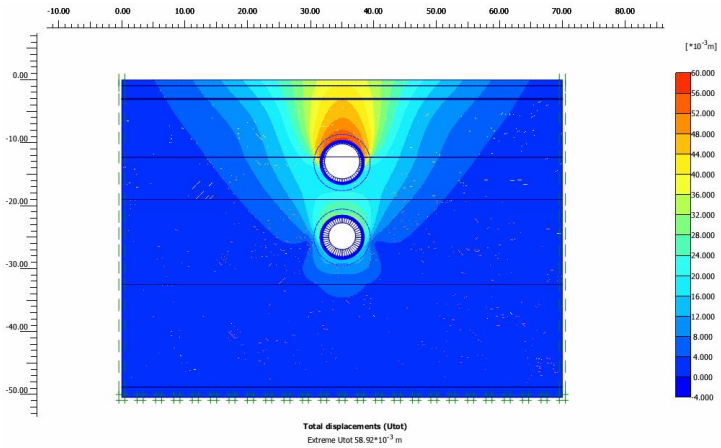

Fig. 5. The distribution of subsidence of surface deformation around the tunnel ($V_L = 1.5\%$)

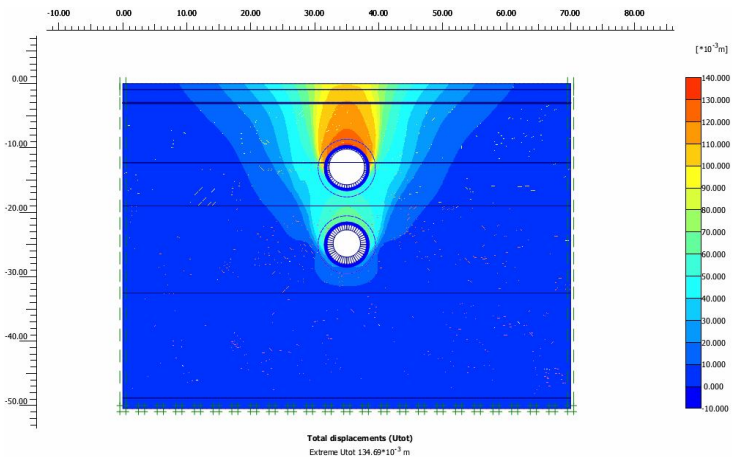

Fig. 6. The distribution of subsidence of surface deformation around the tunnel ($V_L = 3.0\%$)

2.3.3.2. Calculating the settlement of surface deformation after processing by Jet Grouting method:

The use of Plaxis 2D v8.5 is the main method to analyse and calculate the surface deformation when the involvement of the stucco texture format rectangular frame surrounding the 2 tunnels.

The parameters for calculating:

- + The change of thickness δ : 0.5 m, 1 m, 1.5 m, 2 m, 2.5 m and 3 m.
- + The change of Young modulus E: 50MPa, 100MPa, 500MPa, 1000MPa, 2000MPa, 3000MPa, 4000MPa.
- + Distance from outer edge to inwall preserved is 2 m.

The depth of 2 tunnels in turn is 16.444 m for the upper tunnel and 28.324 m for the lower tunnel. Geology in 2 tunnels is mainly sand of the third, fourth, fifth class of soil in the drill hole U150 (2010 design document, QLDSDT Committee). Because of the fact that the construction of two tunnels in the geology is mostly sand soil, the value V_L is got about 0.3% to 0.8%. In this section, the value $V_L = 0.5\%$ is used for all calculations.

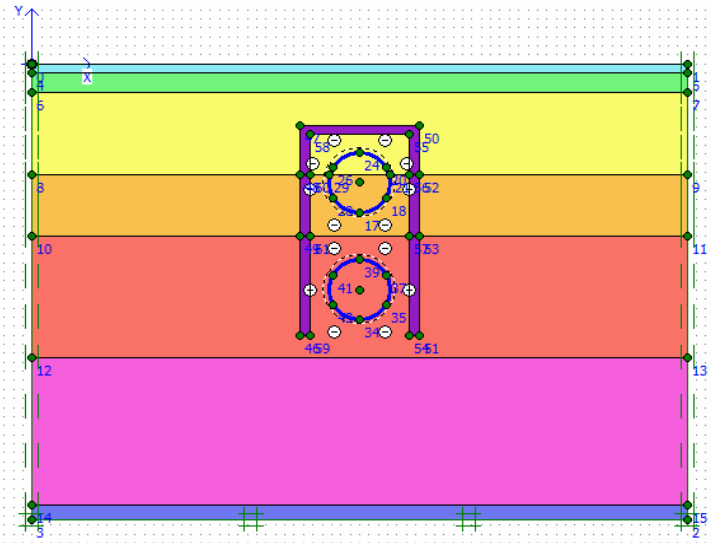

Fig. 7. Computational models using Plaxis 2D

- Calculation results with E-S relations, fixed δ :

With the value $\delta = 1.0$ m (mortar sprayed piles are commonly used) and the change of Elastic Young modulus values about 50MPa, 500MPa, 1000MPa, 2000MPa, 3000MPa, 4000MPa, it is to survey the efficiency of limiting subsidence of surface deformation.

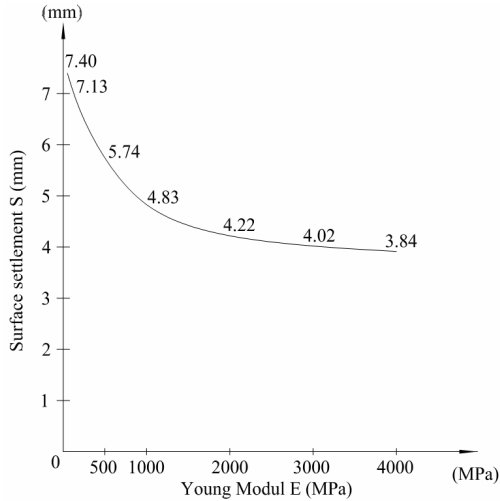

Fig. 8. The relation between Modular E and subsidence of surface deformation with $\delta = 1.0$ m

- Calculation results with δ - S, fixed E:

Fixing the value of Elastic Young modulus $E = 500$ MPa (this is normally the value of module used in cases the land is sand soil), changing the wall thickness of injection mortar δ about 0.5 m, 1.0 m, 1.5 m, 2.0 m, 2.5 m, 3.0 m), it is to survey the relationship between the thickness of the wall plaster spray with limiting the degree of set effectively.

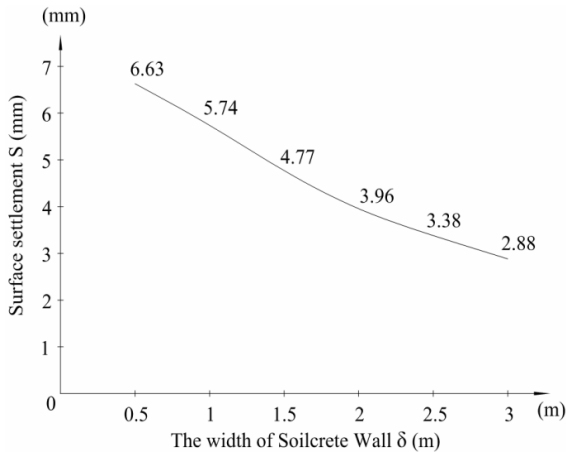

Fig. 9. Relation of thickness of wall plaster spray and subsidence of surface deformation with $E = 500$ MPa

- Calculation results with $\delta - S - E$ for subsidence of surface deformation:

In this content, the value of E is changed in the range from 50 MPa to 1000 MPa, the subsidence of surface deformation is plummeted strongest. The result is represented by the curves on the graph below.

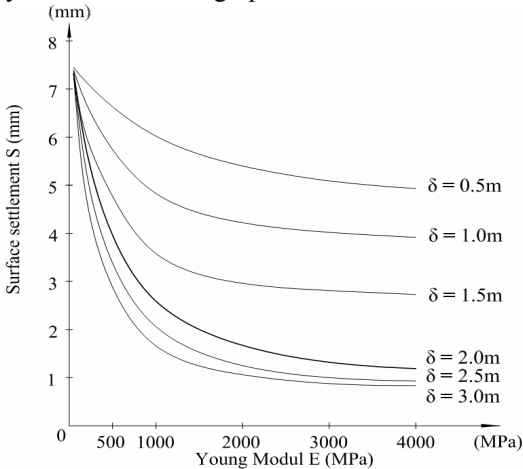

Fig. 10. Relationship among E- δ -S in the surface corresponding to E changed from 50 MPa to 4000MPa

2.3.4. Observations

The higher the value of volume loss V_L is, the more subsidence of surface deformation is increased (table 4), which leads to affect the existing buildings above. Therefore, to overcome the limitation when using shielded methods TBM, it should be considered the use of Jet Grouting method to reduce surface subsidence.

Surface subsidence depends on two factors: the strength of the mortar spray E and the structural geometry of the wall.

When the injection mortar intensity E is increased highly and gained maximum efficiency from 50 MPa to 1000 MPa, the subsidence is falling from 7.40 mm down 4.83 mm (figure 8).

When the injection mortar intensity E is increased from 1000 MPa to 4000 MPa, the subsidence is felt from 4.83 mm down 3.84 mm (figure 8).

When the fixed intensity E = 500 MPa, the surface subsidence is decreased. When increasing the thickness of the wall on average each 0.5 m up, it will reduce the subsidence about 0.75 mm (figure 9).

Thus, the effect of strong subsidence reduction when increasing the injection mortar intensity E from 50 MPa to 1000 MPa and when increasing

insignificantly the injection mortar strength E up from 1000MPa to 4000 MPa (figure 10), while to produce a mixture of great intensity spray mortar, it becomes difficult and the price will be rising. Therefore, the scope of the study should be only considered E from 100MPa to 1000 MPa.

3. Conclusions and recommendations

3.1. The conclusion

In accordance with geological drilling hole with the U-150 at Km0 + 900 on the Metro line 1 (Ben Thanh – Suoi Tien), surface subsidence when constructing the tunnel in the two cases is that there is with Jet grouting and without Jet grouting calculated by finite element method using the Plaxis 2D v.8.5 software as follows:

(1) In the case without Jet Grouting method, this is a rather large result compared with maximum surface subsidence allowed (> 10 mm) with $V_L = 1.5\%$, then $S = 39.82$ mm and $V_L = 3\%$ then $S = 99.46$ mm (table 3)..

(2) In the case of Jet Grouting.

By changing the value of Elastic Young modulus E in the range [50.4000] MPa and thickness of a soilcrete wall δ between [0.5, 3.0] m, calculating the value of surface settlement.

Through the result of research and from the diagrams demonstrating the relationship between the values (surface subsidence S , Young modulus E and thickness δ), it is drawn:

- Price value $V_L = 0.5\%$ is the value which is retrieved as references of experience, in case geology in the area of research is sand and increasing surface settlement depends on the increasing of the V_L .

- When applying the method of Jet Grouting, an intense mortar spraying and thickness of the mortar spray structure are 2 main factors affecting quality of concrete pile and effectively reducing surface subsidence.

- The injection mortar construction affects strongly to the surface subsidence when Young modulus E of the injection mortar is about [50,1000] Mpa. The injection mortar construction affects less when $E > 1000$ MPa (figure 10). Therefore, with the geology of Ho Chi Minh City, $E \leq 1000$ MPa is combined with appropriate thickness, will reduce the level of surface subsidence essentially to ensure design requirements.

3.2. Recommendations

From the results of research at Km0 + 900 of the metro line 1 to Ben Thanh - Suoi Tien, proposal of using Jet Grouting methods to reduce surface subsidence when the tunnel metro is constructed on the particular area and in Ho Chi Minh City in general to make sure the surface settlement smaller than 10mm according to requirements is recommended with the specifications of mortar as followed:

- Ensure construction techniques in the process of Jet Grouting so that the value of Elastic Young modulus value of mortar injection reaches the intensity from 50MPa to 1000Mpa.

- Getting the diameter of mortar injection props can be constructed favorably in case of sand soil of Ho Chi Minh. The value of thickness of mortar injection wall should be about from 1m to 2m.

- After considering the value of Young modulus E and the thickness δ above, it begins to make a field investigation of Jet Grouting with a changed ratio of water and cement, the component of admixture added into the mortar injection, adjusting the pressure of mortar injection and the speed of drawing out the arm, ... After that, it could chose the appropriate components to make the mortar injection, which is suitable for the requirements of design drawing and the application for the project.

REFERENCES

- [1] Management of urban rail (2010), *The document of Designing*.
- [2] Nguyen Tang Thanh Binh, Tran Nguyen Hoang Hung (2013), *Applying grouting to reinforce the Metro line No.1 in Ho Chi Minh city*.
- [3] Nguyen Tran Hoang Hung (2012), *Application of the technology of high pressure grout (Jet Grouting) in Vietnam and development of the Jet Grouting construction equipment*.
- [4] P. P. Xanthakos (1994), *Ground Control and Improvement*.
- [5] R. Essler and H. Yoshida, (2004), *Jet Grouting, Ground Improvement* 2nd Edition By M. P. Moseley and K. Kirsch, Chapter 5, Spon Press: 160-196.
- [6] R. F. Y. Choi (2005), *Review of the jet Grouting Method*.
- [7] Soletanche Bachy (2002), *Expert Solutions in Jet Grouting*.

Nguyen Anh Tuan, Tran Duc Chinh, Nguyen Thanh Dat

THE APPLICATION OF JET GROUTING TECHNOLOGY TO REDUCE GROUND DEFORMATION OF CONSTRUCTION THE METRO LINE IN HO CHI MINH CITY

Slump and subsidence of surface deformation are concerned mostly in the process of construction of the Metro, especially in a weak soil environment, which affects the existence of buildings on the ground. This article introduces the application of Jet Grouting technology to reduce deformation of the surface when the Metro tunnel is constructed in the geological condition of the area of Ho Chi Minh City. Jet Grouting is the mixture of soil and cement (Soilcrete) created by the method of drilling the high grout pressure. The analysis of deformation of soils around the tunnel before and after treated by Jet Grouting method was performed. For the surface subsidence calculation the Finite Element Method was applied. The well known in geotechnical engineering finite element program Plaxis 2D was used for modeling and 2D analysis of the surface settlement varying with the characteristics of soilcrete. It was observed that The higher the value of volume loss is, the more subsidence of surface deformation is increased which leads to affect the existing buildings above tunnel. Therefore, to overcome the limitation when using shielded methods it should be considered the use of Jet Grouting method to reduce surface subsidence. It was marked that surface subsidence depends on two factors: the strength of the mortar spray and the structural geometry of the wall. When the injection mortar intensity is increased highly and gained maximum

efficiency from 50 MPa to 1000 MPa, the subsidence is reducing by 35 percent. When the injection mortar intensity is increased from 1000 MPa to 4000 MPa, the reducing of subsidence reach value of 48 percent. So when applying the method of Jet Grouting, an intense mortar spraying and thickness of the mortar spray structure are two main factors affecting quality of concrete pile and effectively reducing surface subsidence. On the results of research some recommendations was developed which concern setting up the mortar injection suitable for the requirements of design drawing and the application for the project.

Keywords: Surface subsidence, drilling the high grout pressure, Jet Grouting, Soilcrete, Metro.

Нгуєн Ань Туан, Тран Дик Чинь, Нгуєн Тан Дат

ЗАСТОСУВАННЯ ТЕХНОЛОГІЇ СТРУМЕНЕВОГО РОЗЧИНЕННЯ ДЛЯ ЗНИЖЕННЯ ДЕФОРМАЦІЇ ҐРУНТІВ ПРИ БУДІВНИЦТВІ ЛІНІЇ МЕТРО В МІСТІ ХОШИМІН

Деформації ґрунтів враховуються в основному в процесі будівництва метро, особливо в умовах слабкого ґрунтового середовища, що впливає на існування будівель на поверхні землі. Ця стаття представляє застосування технології струменевого розчинення (Jet Grouting) для зменшення деформацій на поверхні землі при будівництві тунелю метро в геологічних умовах області Хошимін. Застосування технології струменевого розчинення в процесі буріння високого тиску утворює суміш ґрунту та цементу (Soilcrete). Використання Jet Grouting для зміцнення ґрунту навколо тунелю розглядається як ефективне рішення для зменшення осідання поверхні землі.

Ключові слова: поверхневі осідання, буріння високого тиску, струменеве розчинення, ґрунтово-цементна суміш, метро.

Нгуєн Ань Туан, Тран Дык Чинь, Нгуєн Тан Дат

ПРИМЕНЕНИЕ ТЕХНОЛОГИИ СТРУЙНОЙ РАСТВОРЕНИЯ ДЛЯ СНИЖЕНИЯ ДЕФОРМАЦИИ ГРУНТА ПРИ СТРОИТЕЛЬСТВЕ ЛИНИИ МЕТРО В ГОРОДЕ ХОШИМИН

Деформации ґрунтов учитываются в основном в процессе строительства метро, особенно в условиях слабого почвенной среды, влияющим на существование зданий на поверхности земли. Эта статья представляет применение технологии струйной растворения (Jet Grouting) для уменьшения деформаций на поверхности земли при строительстве туннеля метро в геологических условиях области Хошимин. Применение технологии струйной растворения в процессе бурения высокого давления образует смесь почвы и цемента (Soilcrete). Использование Jet Grouting для укрепления почвы вокруг туннеля рассматривается как эффективное решение для уменьшения осадки поверхности земли.

Ключевые слова: поверхностная осадка, бурение высокого давления, струйное растворение, ґрунтово-цементная смесь, метро.

УДК 539.3

Nguyen Anh Tuan, Tran Duc Chinh, Nguyen Thanh Dat. Застосування технології струменевого розчинення для зниження деформації ґрунтів при будівництві лінії метро в місті Хошимін // Опір матеріалів і теорія споруд. – 2016. – Вип. 97. – С. 121 – 134.

Застосування технології струменевого розчинення (Jet Grouting) для зміцнення ґрунтів навколо тунелю розглядається як ефективне рішення для зменшення деформацій на поверхні землі при будівництві тунелю метро в геологічних умовах міста Хошимін.

Табл. 4. Іл. 10. Бібліогр. 7 назв.

UDC 539.3

Nguyen Anh Tuan, Tran Duc Chinh, Nguyen Thanh Dat. The application of Jet Grouting technology to reduce ground deformation of construction the metro line in Ho Chi Minh City // Strength of Materials and Theory of Structures. – 2016. – Issue. 97. – P. 121 – 134.

The application of Jet Grouting technology to strengthen the soil around the tunnel is considered as an effective solution to reduce deformations on the surface of the earth during the construction of the metro tunnel in the geological conditions of Ho Chi Minh City.

Table 4. Fig. 10. Ref. 7.

УДК 539.3

Nguyen Anh Tuan, Tran Duc Chinh, Nguyen Thanh Dat. Применение технологии струйной растворения для снижения деформации грунтов при строительстве линии метро в городе Хошимин // Сопротивление материалов и теория сооружений. - 2016. - Вып. 97. - С. 121 - 134.

Применение технологии струйной растворения (Jet Grouting) для укрепления грунтов вокруг тоннеля рассматривается как эффективное решение для уменьшения деформаций на поверхности земли при строительстве тоннеля метро в геологических условиях города Хошимин.

Табл. 4. Ил. 10. Библиогр. 7 назв.

Автор (вчена ступень, вчене звання, посада): *магістр наук факультету транспортного будівництва університету транспорту міста Хо Ши Мін, В'єтнам (MSc. Transportation Engineering Faculty, University of Transport HCMC, Viet Nam) Nguyen Anh Tuan*
Адреса: *02 D3 Street, Ward 25, Binh Thanh District, Ho Chi Minh City, Vietnam.*

Автор (вчена ступень, вчене звання, посада): *доктор наук, професор факультету цивільного будівництва університету транспорту міста Хо Ши Мін, В'єтнам (Faculty of Civil Engineering, Ho Chi Minh city University of Transport) Tran Duc Chinh*
Адреса: *02 D3 Street, Ward 25, Binh Thanh District, Ho Chi Minh City, Vietnam.*
e-mail: *td_chinh@hcmutrans.edu.vn, <http://www.hcmutrans.edu.vn>*

Автор (вчена ступень, вчене звання, посада): *доктор філософії факультету транспортного будівництва університету транспорту міста Хо Ши Мін, В'єтнам (Ph.D Transportation Engineering Faculty, University of Transport HCMC, Viet Nam) Nguyen Thanh Dat*
Адреса: *02 D3 Street, Ward 25, Binh Thanh District, Ho Chi Minh City, Vietnam.*