

Junhong Min (USA), Madhav N. Segal (USA), Debi P. Mishra (USA)

## Modularization as a supplier opportunism safeguard in knowledge process offshoring relationships: theory and empirical evidence

### Abstract

Buyers often procure products and services from suppliers in low cost countries like India and China. Such overseas procurement, or *offshoring*, offers significant direct cost savings vis-a-vis in-house production. Historically, offshoring was primarily confined to manufactured goods. However, in recent years, this practice has spread to the service sector as modern technology has made it possible for geographically dispersed buyers and sellers to interact in real time and exchange data. One area that has witnessed explosive growth is the Knowledge Process Offshoring (KPO) industry comprising services such as marketing and advertising research, financial and management consultancy, research and development, and business and technical analyses, among others. While the main rationale for offshoring knowledge based services centers on direct cost advantages, buyers also have to grapple with an unintended and adverse type of cost inefficiency engendered by supplier opportunism. For example, suppliers have an incentive to expropriate quasi rents by deliberately leaking knowledge based specific assets and diverting them to other clients. Such opportunistic actions expose buyers to significant hidden costs since conventional contractual safeguards breakdown due to information asymmetry, temporal and spatial separation, and vastly different institutional environments facing buyers and sellers. Hence, the overall attractiveness of KPO arrangements is contingent upon effective governance of supplier opportunism. This paper investigates some of the preceding issues by drawing upon Transaction Cost Theory perspectives to develop and empirically test a conceptual model about the antecedents and consequences of supplier opportunism in one KPO setting, i.e., marketing research services. Using an online survey methodology, data were collected from 215 current and future buyers in the market research industry. Results show that suppliers tackle knowledge appropriation hazards by deploying creative non contractual safeguards such as modularization and standardization. Such deterrents curb supplier opportunism and create substantial buyer efficiencies. The paper discusses several managerial and research implications, and outlines the scope for further research.

**Keywords:** opportunism, transaction costs, offshoring, contractual efficiencies, hidden costs, modularization, safeguards, outsourcing.

**JEL Classification:** M31.

### Introduction

Firms face a fundamental choice between using an in-house set-up and contracting with external market based agents. Typically framed as the *make versus buy*, or the *markets versus hierarchy* decision, this governance choice is primarily informed by a vast and growing body of literature commonly referred to as Transaction Cost Economics (TCE). TCE offers normative prescriptions about firms' governance options and holds that the choice between markets and hierarchy is contingent upon the tradeoff between direct in-house production costs and transaction costs of using the market (Williamson, 1975; 2010; Williamson and Ghani, 2012).

In general, direct production costs are minimized when firms use the market or outsource organizational activities. However, markets might contain hidden hazards and present additional risks because contracts cannot always be completely crafted and costlessly enforced (Barthelemy, 2001; Larsen, Manning and Pedersen, 2013). For example, consider the Knowledge Process Offshoring (KPO) industry where buyers procure intangible knowledge intensive services such as marketing research, consulting, and information technology (Javalgi,

Dixit and Scherer, 2009; Quinn and Hilmer, 1994; Sen and Shiel, 2006). In these settings, offshore suppliers may exploit information, knowledge, and spatial asymmetries to opportunistically expropriate quasi-rents (Klein, Crawford and Alchian, 1978). Since knowledge is tacit, embedded, and intangible, buyers can rarely craft a complete contract *ex-ante* to safeguard against *ex-post* supplier opportunism (Stump and Heide, 1996; Wathne and Heide, 2000). Given potential market failure, TCE logic dictates that KPO buyers should boycott the market in favor of an internal command and control hierarchy.

While TCE's fundamental normative prescriptions are theoretically elegant, empirical observation about firms' real life governance choices departs from this neat *market versus hierarchy* abstraction. For example, consider the Knowledge Process Offshoring (KPO) industry comprising services such as marketing and advertising research, financial and management consultancy, research and development, business and technical analyses, and information technology, among others. Given the potential hazards of supplier opportunism in offshore markets, TCE logic dictates that the KPO sector should shrink over time. However, contrary to expectations, the KPO industry has been growing exponentially over the past few years (Davis-Blake and Broschak, 2009; Metter and Verma, 2008; Quinn, 2000; Sen and

Shiel, 2006; Thelen, Yoo and Magnini, 2011; Varadarajan, 2009). As Davis-Blake and Broschak (2009) note, "In 2004, U.S. companies spent over \$16 billion outsourcing information technology jobs ranging from medical transcription to nanotechnology research. In 2008, the level of outsourcing expenditures is expected to grow to \$31 billion for information technology and \$600 billion for all business processes" (p. 322). In summary, it is difficult to reconcile the explosive growth of the modern KPO industry with the normative prescriptions of TCE.

A starting point for reconciling TCE predictions with real life governance structures is to consider the inefficiencies and practical challenges of adopting hierarchical mechanisms. Typically, smaller firms, lacking resources, face stickiness while transitioning to a hierarchy. To overcome such sticky, no-choice challenges, companies deploy creative safeguards against supplier opportunism (Heide and John, 1988), or embrace plural (hybrid) governance forms (Bradach, 1997). For example, in a seminal article, Heide and John (1988) discuss how small insurance service agents who lack the scale to vertically integrate, keep principals' opportunism at bay by forward bonding with customers. Likewise, Bradach (1997) notes how McDonald's uses both company owned (hierarchy) and buy (market) forms simultaneously to control supplier opportunism. Hence, market forms such as KPO arrangements still persist because firms deploy creative safeguards or adopt plural forms to mitigate supplier opportunism. In other words, although TCE predicts the gradual shrinkage of the KPO sector, emerging theory suggests that firms may be able to mimic the advantages of a hierarchy by deploying creative safeguards against offshore suppliers.

In view of the preceding discussion, the central goal of this paper is to understand how one particular creative safeguard, i.e., service modularization, is deployed by buyers in the marketing research KPO industry to combat potential offshore supplier opportunism. Modularization entails breaking down or decoupling an entire project into distinct standardized and functionally independent parts or modules that have to be reassembled to create the final project. The central idea is that if buyers procure individual modules instead of the entire project, the offshore supplier will never be able to gain complete tacit knowledge and understanding about the entire project. The key safeguard here is for the buyer to deliberately create a knowledge deficit so that the seller cannot piece together different pieces of the puzzle. In the end, it is the buyer who reassembles the modules and delivers the complete solution to

customers. In such situations, suppliers can at best gain some fragmented knowledge which is of less value than knowledge about the entire project. This fragmented knowledge is less likely to be expropriated opportunistically by offshore suppliers.

The remainder of this paper is organized as follows. *First*, we discuss the origins of modularization and its relationship to firm strategy. We then describe how modularization can be deployed as a safeguard against supplier opportunism in service settings. Next, we develop a conceptual model and formulate hypotheses about modularization, opportunism, and satisfaction. This is followed by a description of the research design, i.e., development of scale items and the survey instrument, questionnaire administration, sampling, and data collection. In the penultimate section we discuss the results of our empirical tests. *Finally*, we describe the impact of our findings, highlight contributions, and outline directions for future research.

## 1. Modularization and opportunism

A product is the main object of exchange between buyers and sellers and is composed of various components designed to work in unison. In design and engineering terms, firms face a choice while deciding how these components should be related to the final product. At one extreme, parts could be tightly coupled, or highly interdependent, so that modification of an individual component might necessitate a radical redesign of the entire product. On the other hand, components could be independent, modular, and loosely coupled, so that change in one module will not result in major product modification (Sanchez, 1999). For example, consider a personal computer which has several main independent modular components such as hard drives, memory, etc. A designer can easily alter one component such as a memory module without a need to redesign the entire computer. According to research in marketing and management, such deliberate modularization strategies can lead to product customization (Ghosh, Dutta and Stremersch, 2006), flexibility, and speed of innovation (Sanchez, 1999) benefits. Furthermore, firms can outsource the procurement of modularized parts and generate cost efficiencies (Hoetker, Swaminathan and Mitchell, 2007; Sanchez, 1999).

While the concept of modularization was introduced in the context of product design, it applies to service situations equally well. For example, consider a typical consumer segmentation project in marketing. The marketer can decouple the project into several independent modules (e.g., questionnaire development, data collection, data entry, data analysis, tabulations and charting, and report stage). Next, the

marketer considers which of these modules can be effectively and efficiently performed by a supplier. Let's say the marketer decides to purchase data collection services from a supplier and carry out other activities in-house. In the end, the marketer will obtain the modular outsourced service and seamlessly integrate it into the final segmentation study. Notice that the supplier does not have any knowledge about the intended use of the data. Hence, this knowledge deficit precludes any opportunistic behavior on the part of the supplier. Simply put, companies can use a modular procurement strategy not only to realize cost benefits, but also to control the potential supplier opportunism.

## 2. Conceptual model

The conceptual model in Figure 1 depicts the antecedents and consequences of supplier opportunism. In particular, buyers' long-term relationship orientation and proclivity to share information are proposed as antecedents of opportunism, while modularization is proposed as a consequence. We also specify an additional direct path between opportunism and relationship satisfaction, and an indirect path between opportunism and relationship satisfaction that is mediated by modularization. The rationale for our conceptual model together with relevant hypotheses is presented in the next section.

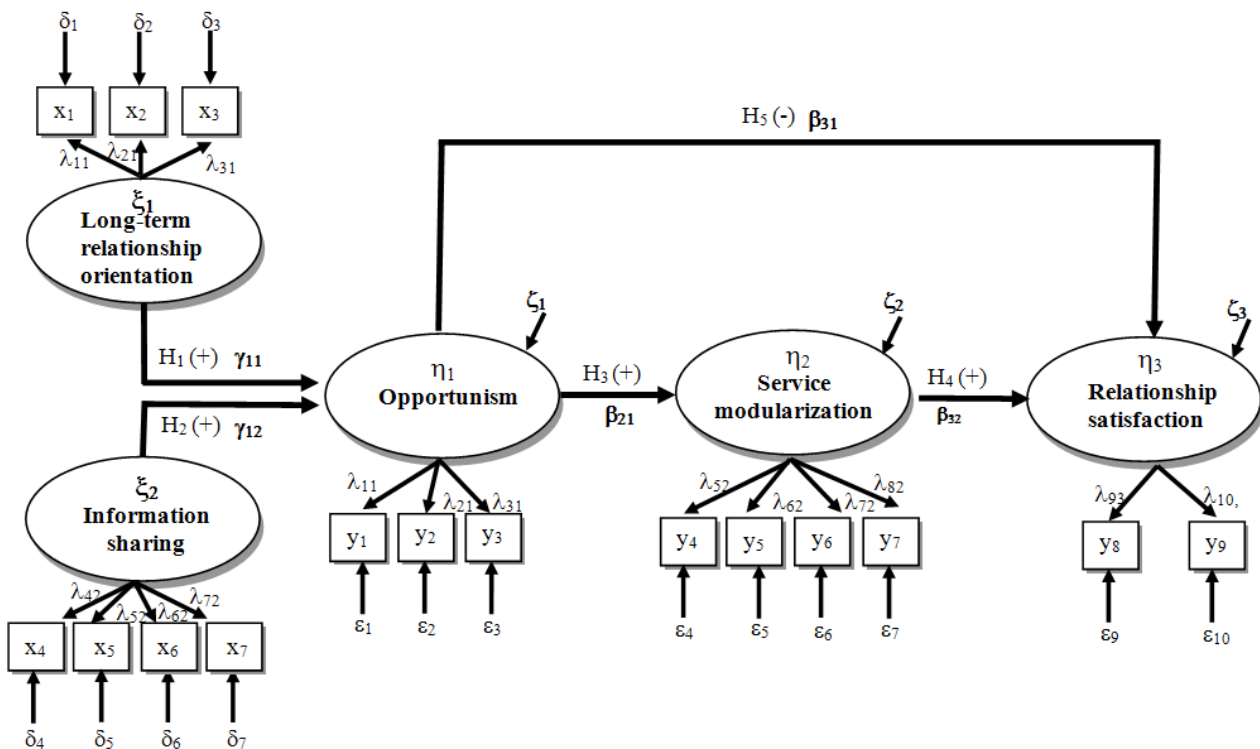

Fig. 1. Conceptual model

## 3. Hypotheses

**3.1. Buyer's long-term relationship orientation and supplier opportunism.** Long-term relationship orientation refers to exchange partners' expectations that a relationship will continue into the future (Ganesan, 1994; Kalwani and Narayandas, 1995). In general, a long-term mindset can lead to positive outcomes given trust and commitment that accompany such mental models (Palmatier, Dant, Grewal, and Evans, 2006).

While the general arguments for the positive effects of a long-term orientation are straightforward, emerging research under the rubric of the 'dark side of marketing relationships' discusses some potentially negative outcomes of a relational mindset (Anderson and Jap, 2005; Grayson and Ambler,

1999; Moorman, Zaltman, and Deshpande, 1992; Noordhoff, Kyriakopoulos, Moorman, Pauwels, and Dellaert, 2011). In general, as per this research stream, higher levels of trust and commitment might have negative outcomes because relationship partners might refrain from undertaking risk and innovating. Consequently, as suggested by Jap (1999), partners might not be motivated to expand the pie. In a related vein, Heide and Wathne (2006), argue that such relationships may come to be dominated by a 'friendship' role based on the logic of appropriateness and therefore not achieve optimal economic outcomes.

In addition to the diminishing and negative returns from increased trust, there is another potential reason for the negative effects of a long-term orientation. Typically, in offshoring situations, buyers are

removed in space and time from overseas suppliers. This knowledge and spatial asymmetry creates significant challenges in monitoring suppliers. Hence, a one sided relationship mindset on the part of the buyer will actually lead to negative outcomes since supplier opportunism cannot be controlled (Barthelemy, 2001; Varadarajan, 2009). In view of the preceding discussion, we offer the following refutable hypothesis for empirical testing:

*H<sub>1</sub>: In offshoring situations, the greater a buyer's long-term relationship orientation, the greater will be the supplier's opportunism.*

**3.2. Buyer's information sharing and supplier opportunism.** Typically, buyers have no choice but to share a certain amount of information with their suppliers with respect to product features, technical specifications, quality, and other issues (Frazier, Maltz, Antia and Rindfleisch, 2009). The main question for a buyer is the extent to which information can be shared with a supplier without incurring adverse costs. At one level, higher amounts of information sharing have been associated with positive benefits like a non-coercive influence strategy (Boyle, Dwyer, Robicheaux and Simpson, 1992), relationship commitment (Anderson and Weitz, 1992; Palmatier, Dant, Grewal and Evans, 2006), relationship satisfaction, and performance (Cannon and Perreault Jr., 1999; Glazer, 1991; Lusch and Brown, 1996). On the other hand, absent safeguards, increased information sharing creates an element of dependence and encourages supplier opportunism (Cannon and Perreault Jr., 1999; Gundlach and Cadotte, 1994; Hewett and Bearden, 2001; Rindfleisch and Moorman, 2001). In offshoring situations, because of informational asymmetries, suppliers are expected to be motivated more by the advantages of expropriating information provided by the buyer than by cooperative considerations. Hence, in hypothesis form:

*H<sub>2</sub>: In offshoring relationships, the greater the buyer's information sharing attitude, the greater will be the supplier's opportunism.*

**3.3. Supplier's opportunism and service modularization.** Opportunism or "self-interest seeking with guile" (Williamson, 1975, p. 6) is a central concept in the inter-firm relationship area (Crosno and Dahlstrom, 2008; Samaha, Palmatier, and Dant, 2011; Stump and Heide, 1996; Wathne and Heide, 2000). Absent appropriate safeguards and governance mechanisms, opportunism creates huge transaction costs and associated inefficiencies (Anderson and Jap, 2005; Heide, Wathne, and Rokkan, 2007). Not surprisingly, a sizeable body of literature has emerged on appropriate mechanisms that firms might deploy to curb partner opportunism.

In the context at hand where a buyer is dealing with an overseas supplier, direct monitoring of the supplier is not a feasible option. In addition, other conventional safeguards such as vertical integration are not available. We argue that offshoring situations are unique given temporal, informational, and knowledge asymmetries that characterize the buyer-seller relationship. As such, we suggest one exclusive type of safeguard that can be deployed by suppliers in such offshoring situations, e.g., modularization. As discussed previously, modularization implies that a project can be broken down into standardized independent modules that can be integrated into a final output only by the buyer who possesses adequate knowledge about the project. The supplier therefore suffers from knowledge deficit and finds it difficult to expropriate information opportunistically. Hence:

*H<sub>3</sub>: The greater the supplier's opportunism, the greater will be the buyer's deployment of the modularization safeguard.*

**3.4. Buyer's service modularization, supplier opportunism, and relationship satisfaction.** In general, buyers who are able to successfully deploy modularization safeguards will be more inclined to believe that opportunism will be kept in check. Such buyers therefore are not concerned about potential asset loss, and therefore weigh the favorable cost savings from outsourcing more positively. In contrast, this positive view is compromised because of potential opportunism that might still be present in the relationship in a residual sense. Notice that although modularization is deployed as a safeguard, it might not adequately control all aspects of opportunism (deliberate project delays, unauthorized modifications, unnecessary tinkering). Hence, we offer the following hypotheses for empirical testing:

*H<sub>4</sub>: The greater the buyer's deployment of modularization, the greater will be the buyer's relationship satisfaction.*

*H<sub>5</sub>: The greater the supplier's opportunism, the lower will be the buyer's relationship satisfaction.*

#### 4. Research design

We studied the relationship between buyers in the U.S. and their global suppliers. From a total of two hundred fifteen current and future buyers from a nationwide online survey, we selected only current 'active' buyers to test the proposed model and the hypotheses.

**4.1. Survey context.** We selected marketing research service as our context because of the following reasons. First, an overseas marketing research service

supplier's opportunism is difficult to monitor because important knowledge and skills are hidden inside the supplier. Second, modularization as a safeguard appears to be widely prevalent in the marketing research offshoring setting. Specifically, marketing research service processes are relatively easy to modularize into standardized stages (e.g., online survey hosting, data collection, recruiting, data coding and input, and data analysis). Finally, in these offshore settings, it is very uncommon for firms to set aside resources for directly monitoring overseas suppliers. Under these conditions, unique governance mechanisms such as modularization assume importance.

**4.2. Sampling frame and key informant selection.** We obtained the list of firms from the *Quirk's Marketing Research Review*. The *Quirk's Marketing Research Review* is one of the few specialized and well-known sources that identify and publish the names of marketing research service buyers and their overseas suppliers. The sample list provides names, titles, and email addresses of prospective key informants. The key informants in this sample

were expected to be knowledgeable about their company policies and outsourcing decisions. Most respondents held upper-level management positions (e.g. CEO, president, owner, and managers). After removing firms without email addresses and other contact information, the initial sampling frame consisted of 2,919 firms.

**4.3. Questionnaire and measures.** The questions in our online survey consisted of four parts, i.e., (1) a range of descriptive questions about suppliers (e.g., respondent job title, revenue, number of employees, and a screening question about the use of services), (2) measures of constructs discussed earlier, and (3) an important control variable-years spent in the marketing research industry. Before distributing the final questionnaire to the key informants, seven marketing research practitioners participated in several pilot tests. Based on their feedback, a few changes were made and integrated into the final online survey. Table 1 displays the scale items and their psychometric properties. The correlation matrix is depicted in Table 2.

Table 1. Scale items and reliability

Construct	Item	Scale item <sup>d</sup>	$\mu^a$	$\sigma^b$	$\alpha^c$
Long-term relationship orientation	x <sub>1</sub>	Over the long run, a relationship with this supplier will be profitable for our company	3.64	0.93	0.92
	x <sub>2</sub>	Maintaining a long-term relationship with this supplier is important for our company	3.75	0.97	
	x <sub>3</sub>	Our company is willing to make sacrifices to help this supplier from time to time	3.43	0.98	
Information sharing	x <sub>4</sub>	Our company shares information about our internal training programs that will help this supplier	2.75	0.86	0.88
	x <sub>5</sub>	Our company shares information about useful resources that will help this supplier	3.06	0.97	
	x <sub>6</sub>	Our company shares know-how with this supplier	3.29	1.03	
	x <sub>7</sub>	Our company shares information about internal procedures and routines with this supplier	3.56	1.07	
Opportunism	y <sub>1</sub>	This supplier thinks that it is alright not to discuss what our company doesn't want to hear	2.88	1.05	0.83
	y <sub>2</sub>	This supplier exaggerates their difficulties experienced while working with us	2.44	0.87	
	y <sub>3</sub>	This supplier representative often changes his/her belief if it differs from what our company doesn't want to know	3.71	0.99	
Service modularization	y <sub>4</sub>	Our company standardizes each stage of marketing research process	4.29	1.01	0.92
	y <sub>5</sub>	Each stage of the marketing research process is well-documented	4.47	0.97	
	y <sub>6</sub>	Our employee's job description is defined based on each stage of marketing research process	4.18	1.13	
	y <sub>7</sub>	Our company's marketing research process can be modularized	4.00	0.95	
Relationship satisfaction	y <sub>8</sub>	How satisfied is your company with the relationship with this supplier	4.95	1.57	0.82
	y <sub>9</sub>	How satisfied is your company with the outcomes from this supplier	4.38	1.29	

Notes: <sup>a</sup> Refers to item mean; <sup>b</sup> refers to standard deviation; <sup>c</sup> refers to composite scale reliability (Cronbach's alpha); <sup>d</sup> 7- point Likert scale with strongly disagree and strongly agree as anchors. Anchors for the relationship satisfaction items were "Not at all satisfied" and "Extremely satisfied". Supplier refers to an OMRO (Overseas Market Research Organization) supplier.

Table 2. Correlation matrix

	x <sub>1</sub>	x <sub>2</sub>	x <sub>3</sub>	x <sub>4</sub>	x <sub>5</sub>	x <sub>6</sub>	x <sub>7</sub>	y <sub>1</sub>	y <sub>2</sub>	y <sub>3</sub>	y <sub>4</sub>	y <sub>5</sub>	y <sub>6</sub>	y <sub>7</sub>	y <sub>8</sub>	y <sub>9</sub>
x <sub>1</sub>	1.000															
x <sub>2</sub>	.965**	1.000														
x <sub>3</sub>	.728**	.690**	1.000													
x <sub>4</sub>	.291*	.362**	.367**	1.000												
x <sub>5</sub>	.385**	.366**	.608**	.566**	1.000											
x <sub>6</sub>	.328*	.381**	.362**	.666**	.717**	1.000										
x <sub>7</sub>	.336**	.400**	.442**	.437**	.740**	.758**	1.000									
y <sub>1</sub>	.367**	.451**	.067	.363**	.272*	.345**	.427**	1.000								
y <sub>2</sub>	.522**	.508**	.289*	.276*	.457**	.244	.317*	.799**	1.000							
y <sub>3</sub>	.413**	.421**	.119	-.156	.112	-.059	.094	.486**	.581**	1.000						

Table 2 (cont.). Correlation matrix

	X <sub>1</sub>	X <sub>2</sub>	X <sub>3</sub>	X <sub>4</sub>	X <sub>5</sub>	X <sub>6</sub>	X <sub>7</sub>	Y <sub>1</sub>	Y <sub>2</sub>	Y <sub>3</sub>	Y <sub>4</sub>	Y <sub>5</sub>	Y <sub>6</sub>	Y <sub>7</sub>	Y <sub>8</sub>	Y <sub>9</sub>
Y <sub>4</sub>	.504**	.546**	.520**	.499**	.554**	.422**	.427**	.318**	.494**	.384**	1.000					
Y <sub>5</sub>	.438**	.535**	.388**	.502**	.559**	.617**	.703**	.509**	.408**	.346*	.803**	1.000				
Y <sub>6</sub>	.453**	.543**	.556**	.676**	.623**	.696	.769**	.484**	.439**	.059	.783**	.812**	1.000			
Y <sub>7</sub>	.609**	.635**	.687**	.534**	.730**	.495**	.693**	.347*	.386**	.146	.629**	.753**	.691**	1.000		
Y <sub>8</sub>	.463**	.533*	.527**	.392**	.445**	.466**	.753**	.433**	.402**	.066	.579**	.662**	.851**	.609**	1.000	
Y <sub>9</sub>	.507**	.541**	.461**	.116	.171	.151	.476**	.195	.192	.300**	.520**	.605**	.537**	.596**	.695**	1.000

Notes: x<sub>1</sub>, x<sub>2</sub>, x<sub>3</sub> – long-term relationship orientation; x<sub>4</sub>, x<sub>5</sub>, x<sub>6</sub>, x<sub>7</sub> – information sharing; y<sub>1</sub>, y<sub>2</sub>, y<sub>3</sub> – opportunism; y<sub>4</sub>, y<sub>5</sub>, y<sub>6</sub>, y<sub>7</sub> – modularization; y<sub>8</sub>, y<sub>9</sub> – relationship satisfaction. \*Correlation is significant at the 0.01 level ( $p < 0.05$ ); \*\* correlation is significant at the 0.01 level ( $p < 0.01$ ).

To ensure adequate reliability of measures, constructs were measured using multiple items. *First*, we defined long-term relationship orientation as the orientation of a buyer toward developing long-term relationship with an overseas supplier. We used three items based on Ganesan’s (1994) study. The scale items are depicted in Table 1. The three-item scale’s reliability estimate was 0.92. *Second*, information sharing refers to the buyer’s strategic support for its supplier evidenced by sharing internal information, resources, or offering special learning opportunities that may enhance the supplier’s performance outcomes. Based on several prior studies (Cannon and Perreault Jr., 1999; Frazier, Maltz, Antia and Rindfleisch, 2009), four scale items were used. The four-item scale’s reliability estimate was 0.88. *Third*, opportunism is defined as “self-interest seeking with guile” (Williamson, 1975, p. 6). On the basis of several prior studies (Grayson and Ambler, 1999; Heide, Wathne and Rokkan, 2007; Anderson and Jap, 2005), we developed three scale items depicted in Table 1. The scale’s reliability estimate was 0.83. *Fourth*, on the basis of previous studies by Sanchez (1999) and Ghosh, Dutta and Stremersch (2006), we developed four scale items for service modularization involving standardizing each stage of the marketing research process, documenting each stage of the marketing research process, job descriptions associated with each stage of marketing research process, and capability of modularization. The four-item scale’s reliability estimate was 0.92. *Finally*, the relationship satisfaction scale used in this research consisted of two scale items focusing on overall satisfaction of the relationship and satisfaction with outcomes. The two-item scale’s reliability estimate was 0.82.

**4.4. Data collection procedure and response rate.**

We chose an online survey procedure as our data collection method. Major strengths of the web survey approach include easy sampling management, fast and accurate data entry, effective advance notification control, and a scheduled follow-up system (Couper, Traugott and Lamias,

2001). Although prior studies have used online surveys some concerns such as low response rates (Roster, Rogers, Hozier Jr., Baker and Albaum, 2007) have also surfaced.

To minimize the response rate problem, we followed the approach suggested by Kaplowitz, Hadlock and Levine (2004). *First*, email notifications were sent to all subjects in the sample list. *Second*, another email containing a cover letter with instructions to complete the online survey and a hyper-text link which connected the subjects to the online survey was distributed to 2,919 marketing research companies. We also provided some basic definitions about outsourcing, offshoring, and overseas market research organizations (ORMO) to ensure all respondents understood the relevant concepts. *Finally*, a reminder email was sent a week following the start of the field work to increase the response rate.

The online survey software we used to collect data is commercially known by the brand name of *SurveyMonkey.com*. The online survey was conducted for 1 month and we collected a total of 215 usable surveys. Thus, the overall response rate is 7%.

**5. Survey results**

**5.1. Sample description.** The respondents in this data analysis had an average of 24 years of experience in the marketing research industry and an average of 15 years working in their current companies. A large number of respondents held leadership positions such as CEO, President or Chairman (50%), Owner (26%) or V.P. (11%). These statistics supported our assumption that key informants in this research would be greatly involved in the respondent firms’ decision making processes. About half the firms (50.5%) had average revenues of less than \$350,000. The average revenue for the top 25% of the firms in the sample was more than \$2,000,000. On an average, the mean age of the buyer-supplier relationship was 3.8 years.

**5.2. Top five future OMRO activities.** The 215 respondents were asked which marketing research projects were likely to be outsourced in the near

future. The survey results revealed that “Internet survey hosting” is the most desired activity in the quantitative research area while it is “chart or slide production” in the qualitative research area (see Table 3).

Table 3. Top 5 future OMRO activities in quantitative and qualitative research area

Top 5 future OMRO activities in quantitative research area		Top 5 future OMRO activities in qualitative research area	
Category	% of future usage	Category	% of future usage
Internet survey hosting	69%	Chart or slide production	73%
Online survey programming	68%	Discussion/interview guideline development	72%
CATI	65%	Ethnography study	72%
Intercept research support	65%	Moderating tasks	72%
CAPI	65%	Audio/video transcribing	71%

Note:  $n = 215$ , multiple responses were allowed.

**5.3. Current status of offshoring.** The results from the survey revealed that only 2% out of two hundred fifteen marketing research service buyers have procured from their global suppliers. The result indicates that offshore marketing research outsourcing is still in a developmental stage and a new business trend in the marketing research sector.

## 6. Hypotheses testing

**6.1. Key informant check.** Of the 215 current and future buyers, only 59 current buyers were included in testing the proposed model and hypotheses. To investigate whether current service users ( $n = 59$ ) and non-users ( $n = 156$ ) were systematically different, we

conducted *t*-tests with several descriptive variables about characteristics of key informant (e.g., years working in company, years working in marketing research industry) and that of the firm (e.g., revenue and years of business in marketing research industry). The results of *t*-tests showed that the null hypothesis of indifference between current service users and non-users was not rejected for “number of years hired years in company” ( $t = 1.554, p = .696$ ), “years working in marketing research industry” ( $t = 1.219, p = .750$ ), “revenue ( $t = .572, p = .200$ ), and “years of business in marketing research ( $t = .176, p = .213$ ). Although the results suggest that there was no systematic difference between buyers and non-buyers, their knowledge about firms’ service management and policies were expected to be different. Hence, we conducted additional *t*-test analysis to examine the hypothesis that the two groups were not different in terms of their knowledge of service. Results showed that these two groups were different in terms of amount of knowledge about service ( $t = 9.012, p = 0.001$ ).

**6.2. Reliability.** As shown in Table 1, the values of Cronbach  $\alpha$  for all constructs ranged from 0.78 to 0.92.

**6.3. Construct validation.** First, as depicted in Table 4, overall goodness of fit indices for the measurement model was acceptable. Hu and Bentler (1998) recommend that acceptable value of CFI should be close to 0.95, with a SRMR of 0.08. Results of the EQS program show that the comparative fit index (CFI) was 0.993, while the standardized root mean square residual (SRMR) was 0.032. All items loaded on their respective latent constructs, and are positive and significant.

Table 4. Results of measurement model

Item	Variable	Estimate	<i>t</i>
Long-term relationship orientation ( $\xi_1$ )			
$x_1$	$\lambda_{11}$	.980	7.229**
$x_2$	$\lambda_{21}$	.992	7.263**
$x_3$	$\lambda_{31}$	.698	- <sup>a</sup>
Information sharing ( $\xi_2$ )			
$x_4$	$\lambda_{41}$	.701	5.924**
$x_5$	$\lambda_{51}$	.828	7.492**
$x_6$	$\lambda_{61}$	.864	7.975**
$x_7$	$\lambda_{71}$	.835	- <sup>a</sup>
Opportunism ( $\eta_1$ )			
$y_1$	$\lambda_{11}$	.847	4.547**
$y_2$	$\lambda_{21}$	.899	4.574**
$y_3$	$\lambda_{31}$	.581	- <sup>a</sup>
Service modularization ( $\eta_2$ )			
$y_4$	$\lambda_{41}$	.793	6.399**
$y_5$	$\lambda_{52}$	.846	6.907**
$y_6$	$\lambda_{62}$	.970	8.102**
$y_7$	$\lambda_{73}$	.751	- <sup>a</sup>

Table 4 (cont.). Results of measurement model

Item	Variable	Estimate	t
Relationship satisfaction ( $\eta_3$ )			
$\gamma_8$	$\lambda_{84}$	1.00	7.123**
$\gamma_9$	$\lambda_{93}$	.683	-.a
Overall goodness of fit indices			
$\chi^2$ <sup>p</sup>	691.863	df = 94	$p < 0.001$
NFI <sup>c</sup>	.991		
NNFI <sup>d</sup>	.990		
CFI <sup>e</sup>	.992		
SRMR <sup>f</sup>	.032		

Notes: <sup>a</sup> Fixed to one for identifying the corresponding parameter; <sup>b</sup> average model Chi-square; <sup>c</sup> average normed fit index; <sup>d</sup> average non normed fit Index; <sup>e</sup> average comparative fit index; <sup>f</sup> average standardized root mean-square residual. \*\* Correlation is significant at the 0.01 level ( $p < 0.01$ ).

We followed Anderson and Gerbing's (1988) guidelines to assess discriminant validity. To assess discriminant validity, we first ran a confirmatory factor analysis restricting correlations pair-wise to unity ( $\Phi_{ij} = 1.0$ ). We then ran a second confirmatory factor analysis relaxing the previous assumption that correlation between the two estimated constructs was one. Next, we performed a chi-square test of differences by subtracting the value of  $\chi^2$  of the first confirmatory factor analysis from the second confirmatory factor analysis. If this computed value of  $\chi^2$  difference was statically significant (e.g., exceeding +/- 3.841 with 1 degree of freedom for a 0.05 size test), it provided evidence of discriminant

validity. Finally, in addition to the Chi-square different test, we examined the comparative fit index (CFI) and the standardized root mean square residual (SRMR) for the two estimated constructs. The results of discriminant validity analysis are available in Table 5.

The results of the  $\chi^2$  test of differences between the models restricting factor inter-correlations for long-term relationship, information sharing ( $\Phi_{ij} = 1.0$ ) and the unrestricted model was significant. Similar tests were obtained for service modularization, opportunism, and relationship. Results showed that in general, discriminant validity of the measures was achieved.

Table 5. Results of discriminant validity test

	Variable	Goodness of fit				Discriminant validity (model comparisons)		
		$\chi^2$ <sup>a</sup>	df	CFI <sup>b</sup>	$p$	$\Delta\chi^2$	$\Delta df$	$p$
Independent variable	Long-term relationship orientation ( $\xi_1$ ), information sharing ( $\xi_2$ ),							
	$\Phi(\xi_1, \xi_2) = 1.0$	705.46	95	.992	< 0.01	13.59	1	< 0.01
Dependent variable	Opportunism ( $\eta_1$ ), Service modularization ( $\eta_2$ ), Relationship satisfaction ( $\eta_3$ )							
	$\Phi(\eta_1, \eta_2) = 1.0$	712.07	95	.991	< 0.01	20.2	1	< 0.01
	$\Phi(\eta_1, \eta_3) = 1.0$	708.81	95	.992	< 0.01	16.9	1	< 0.01
	$\Phi(\eta_2, \eta_3) = 1.0$	697.59	95	.993	< 0.01	5.7	1	< 0.05

Notes: <sup>a</sup> Tests the null hypothesis that the population covariance matrix and the covariance matrix implied by sample parameters are equal. <sup>b</sup> Comparative fit index.

Table 6. Results of structural paths

Hypotheses	Independent variable	Dependent variable	Path	Estimate	t	$p$
H <sub>1</sub>	Long-term relationship orientation ( $\xi_1$ )	Opportunism ( $\eta_1$ )	$\gamma_{11}$	.474	2.769	< 0.05
H <sub>2</sub>	Information sharing ( $\xi_2$ )	Opportunism ( $\eta_1$ )	$\gamma_{12}$	.307	2.091	< 0.05
H <sub>3</sub>	Opportunism ( $\eta_1$ )	Service modularization ( $\eta_2$ )	$\beta_{21}$	.590	3.080	< 0.05
H <sub>4</sub>	Service modularization ( $\eta_2$ )	Relationship satisfaction ( $\eta_3$ )	$\beta_{32}$	.833	4.475	< 0.05
H <sub>5</sub>	Opportunism ( $\eta_1$ )	Relationship satisfaction ( $\eta_3$ )	$\beta_{31}$	.002	.021	NS <sup>*</sup>
Overall goodness of fit indices						
			$\chi^2$ <sup>a</sup>	754.959	df = 99	$p < 0.01$
			NFI <sup>b</sup>	.990		



Table 6. Results of structural paths

Overall goodness of fit indices					
			NNFI <sup>c</sup>	.990	
			CFI <sup>d</sup>	.992	
			SRMR <sup>e</sup>	.034	

Notes: <sup>a</sup> Tests the null hypothesis that the population covariance matrix and the covariance matrix implied by sample parameters are equal; <sup>b</sup> normed fit index; <sup>c</sup> non-normed fit index; <sup>d</sup> comparative fit index; <sup>e</sup> average standardized root mean-square residual. \* Not significant.

**6.4. Overall goodness of fit.** As indicated in Table 6, the estimated  $\chi^2$  statistic for the structural model was significant ( $\chi^2 = 811.44$ ,  $df = 115$ ,  $p = < 0.01$ ), suggesting that the hypothesized model reproduces sample correlations within sample error (Bentler, 1995, p. 93). However, since the  $\chi^2$  statistic is often susceptible to sample size issues, we investigated several additional goodness of fit indexes including the normed fit index (NFI), the non-normed fit index (NNFI), the comparative fit index (CFI), and the standardized root mean square residual (SRMR). The results show that NFI, NNFI, and CFI were close to the recommended cut-off level of 0.90, and SRMR was 0.034. Thus, we conclude that the hypothesized structural model provides a good fit to the data.

**6.5. Parameter estimates.** A structural equation analysis (EQS software) was used to estimate the model parameters. *First*, the hypothesized structural path from the buyer's long-term relationship orientation to supplier's opportunism (H1) is statistically significant and positive ( $\gamma_{11} = .474$ ,  $t = 2.769$ ). *Second*, the path from buyer's information sharing to supplier's opportunism (H2) is also positive and significant ( $\gamma_{12} = .307$ ,  $t = 2.091$ ). Thus, both H1 and H2 were accepted.

*Third*, we examined the relationship between the supplier's opportunism and service modularization. Results show that this path was positive and significant ( $\beta_{21} = .590$ ,  $t = 3.080$ ), which supports H3. *Fourth*, to test H4, we investigated the relationship between service modularization and the buyer's relationship satisfaction. Results showed that the standardized coefficient of the path from service modularization to the buyer's relationship satisfaction ( $\beta_{32} = .833$ ,  $t = 4.475$ ) was positive and significant.

*Finally*, to test H5, we examined the indirect impact of opportunism on relationship satisfaction. As expected, the indirect impact of supplier's opportunism was weak and statistically insignificant ( $\beta_{31} = .002$ ,  $t = .021$ ).

## Conclusion

We argued at the outset that the phenomenon of offshoring services is a relatively new and growing trend. While practitioners in the field of marketing research are generally aware of the unique benefits of the offshoring marketing research activities, academicians generally draw attention to the

challenges in such relationships especially concerning supplier opportunism. Interestingly, while there is a vast amount of research in the area of governance mechanisms for controlling opportunism, there is a paucity of work in the area of offshoring relationships involving marketing research firms. This study attempts to fill a gap in our understanding of such relationships by studying how firms might deploy creative safeguards such as modularization in offshoring situations.

The findings of this research support our hypothesis that modularization can be deployed as a strategic mechanism to control supplier opportunism. More specifically, this research makes two important contributions. *First*, prior studies in outsourcing look at the make or buy decision rather narrowly in terms of cost minimization (Quinn and Hilmer, 1994), or the choice between single and multiple sourcing (Stremersch, Weiss, Dellaert and Frambach, 2003). In contrast, we believe that modularization serves a dual purpose of acting as a viable supplier safeguard, while contributing to value. Note that overseas suppliers typically possess considerable expertise and knowledge, and firms' ability to tap into this mind set yields unique benefits.

*Second*, and as noted earlier, our research provides evidence that service modularization plays an important role in governing partner opportunism when knowledge, experience, and skills are present in buyer-supplier relationships.

## Limitations and future research

As in any research, this study is not without its limitations. *First*, the relatively small sample size might have biased certain parameter estimates. To this extent, future research can build upon this exploratory study using more robust and comprehensive research designs. *Second*, it may be worthwhile to investigate whether there is any variation in the use of modularization across different cultural situations. It is conceivable that certain institutional environments might amplify or diminish the importance of this construct. For example, in naturally trusting cultures like Japan and Korea, it is possible that modularization may not be an effective strategy to control opportunism. *Finally*, it would be interesting to investigate what effect modularization has when deployed jointly with other conventional safeguards.

## References

1. Anderson, Erin and Barton Weitz (1992). The Use of Pledges to Build and Sustain Commitment in Distribution Channels, *Journal of Marketing Research*, 29, pp. 18-34.
2. Anderson, Erin and Sandy D. Jap (2005). The Dark Side of Close Relationships, *Sloan Management Review*, 46 (3), pp. 74-82.
3. Anderson, James C. and David W. Gerbing (1988). Structural Equation Modeling in Practice: A Review and Recommended Two-Step Approach, *Psychological Bulletin*, 103 (3), pp. 411-423.
4. Barthelemy, Jerome (2001). The Hidden Costs of IT Outsourcing, *MIT Sloan Management Review*, 42 (Spring), pp. 60-69.
5. Bentler, Peter M. (1995). *EQS: Structural Equations Program Manual*, Encino, CA: Multivariate Software, Inc.
6. Boyle, Brett, F. Robert Dwyer, Robert A. Robicheaux and James T. Simpson (1992). Influence Strategies in Marketing Channels: Measures and Use in Different Relationship Structures, *Journal of Marketing Research*, 29 (4), pp. 462-473.
7. Bradach, Jeffrey L. (1997). Using the Plural Form in the Management of Restaurant Chains, *Administrative Science Quarterly*, 42, pp. 276-303.
8. Cannon, Joseph P. & William D. Perreault, Jr. (1999). Buyer-Seller Relationships in Business Markets, *Journal of Marketing Research*, 36, pp. 439-460.
9. Couper, Mick P., Michael W. Traugott, and Mark J. Lamias (2001). Web Survey Design and Administration, *Public Opinion Quarterly*, 65 (2), pp. 230-253.
10. Crosno, Jody L. and Robert Dahlstrom (2008). A Meta-Analytic Review of Opportunism in Exchange Relationships, *Journal of Academy of Marketing Science*, 36, pp. 191-201.
11. Davis-Blake, Alison and Joseph P. Broschak (2009). Outsourcing and the Changing Nature of Work, *Annual Review of Sociology*, 35, pp. 321-340.
12. Frazier, Gary L., Elliot Maltz, Kersi D. Antia, and Aric Rindfleisch (2009). Distributor Sharing of Strategic Information with suppliers, *Journal of Marketing*, 73, pp. 31-43.
13. Ganesan, Shankar (1994). Determinants of Long-Term Orientation in Buyer-Seller Relationships, *Journal of Marketing*, 58, pp. 1-19.
14. Ghosh, Mrinal, Shantanu Dutta and Stefan Stremersch (2006). Customizing Complex Products: When Should the Vendor Take Control, *Journal of Marketing Research*, 43, pp. 664-679.
15. Glazer, Rashi (1991). Marketing in an Information-Intensive Environment: Strategic Implications of Knowledge as an Asset, *Journal of Marketing*, 55, pp. 1-19.
16. Grayson, Kent and Tim Ambler (1999). The Dark Side of Long-Term Relationships in Marketing Services, *Journal of Marketing Research*, 36, pp. 132-141.
17. Gundlach, Gregory T. and Ernest R. Cadotte (1994). Exchange Interdependence and Inter-firm Interaction: Research in Simulated Channel Setting, *Journal of Marketing Research*, 31 (4), pp. 516-532.
18. Heide, Jan B. and George John (1988). The Role of Dependence Balancing in Safeguarding Transaction-Specific Assets in Conventional Channels, *Journal of Marketing*, 52, pp. 20-35.
19. Heide, Jan B. and Kenneth H. Wathne (2006). Friends, Businesspeople, and Relationship Roles: A Conceptual Framework and a Research Agenda, *Journal of Marketing*, 70, pp. 90-103.
20. Heide, Jan B., Kenneth H. Wathne, and Aksel I. Rokkan (2007). Interfirm Monitoring, Social Contracts, and Relationship Outcomes, *Journal of Marketing Research*, 44, pp. 425-433.
21. Hewett, Kelly and William O. Bearden (2001). Dependence, Trust, and Relational Behavior on the Part of Foreign Subsidiary Marketing Operations: Implications for Managing Global Marketing Operations, *Journal of Marketing*, 65 (4), pp. 51-66.
22. Hoetker, Glenn, Anand Swaminathan and Will Mitchell (2007). Modularity and the Impact of Buyer-Supplier Relationships on the Survival of Suppliers, *Management Science*, 53 (2), pp. 178-191.
23. Hu, Li-tze and Peter M. Bentler (1998). Fit Indices in Covariance Structure Modeling: Sensitivity to Underparameterized Model Misspecification, *Psychological Methods*, 3 (4), pp. 424-453.
24. Jap, Sandy D. (1999). Pie-expansion efforts: Collaboration Processes in Buyer-Supplier Relationships, *Journal of Marketing Research*, 36, pp. 461-475.
25. Javalgi, Rajshekhar G., Ashutosh Dixit and Robert F. Scherer (2009). Outsourcing to emerging markets: Theoretical perspective and policy implications, *Journal of International Management*, 15, pp. 156-168.
26. Kalwani, Manohar U. and Narakesari Narayandas (1995). Long-Term Manufacturer Relationships: Do They Pay Off for Firms, *Journal of Marketing*, 59, pp. 1-16.
27. Kaplowitz, Michael D., Timothy D. Hadlock and Ralph Levine (2004). A Comparison of Web and Mail Survey Response Rates, *Public Opinion Quarterly*, 68 (1), pp. 94-101.
28. Klein, Benjamin, Robert G. Crawford and Armen A. Alchian (1978). Vertical Integration, Appropriable Rents, and the Competitive Contracting Process, *Journal of Law and Economics*, 21 (2), pp. 297-326.
29. Larsen, Marcus M., Stephan Manning and Torben Pedersen (2013). Uncovering the Hidden Costs of Offshoring: The Interplay of Complexity, Organizational Design, and Experience, *Strategic Management Journal*, 34, pp. 533-552.

30. Lusch, Robert F. and James R. Brown (1996). Interdependency, Contracting, and Relational Behavior in Marketing Channels, *Journal of Marketing*, 60, pp. 19-38.
31. Metters, Richard and Rohit Verma (2008). History of offshoring knowledge services, *Journal of Operations Management*, 26, pp. 141-147.
32. Moorman, Christine, Gerald Zaltman and Rohit Deshpande (1992). Relationships between suppliers and users of market research: The Dynamics of Trust within and between organizations, *Journal of Marketing Research*, 29, pp. 314-328.
33. Noordhoff, Corine S., Kyriakos Kyriakopoulos, Christine Moorman, Pieter Pauwels and Benedict G.C. Dellaert (2011). The Bright Side and Dark Side of Embedded Ties in Business-to-Business Innovation, *Journal of Marketing*, 75, pp. 34-52.
34. Quinn, James B. (2000). Outsourcing Innovation: The New Engine of Growth, *Sloan Management Review*, 41 (4), pp. 13-28.
35. Quinn, James and Frederick G. Hilmer (1994). Strategic Outsourcing, *Sloan Management Review*, pp. 43-55.
36. Palmatier, Robert W., Rajiv P. Dant, Dhruv Grewal and Kenneth R. Evans (2006). Factors Influencing the Effectiveness of Relationship Marketing: A Meta-Analysis, *Journal of Marketing*, 70, pp. 136-153.
37. Rindfleisch, Aric and Christine Moorman (2001). The Acquisition and Utilization of Information in New Product Alliances: A Strength-of-Ties Perspective, *Journal of Marketing*, 65, pp. 1-18.
38. Roster, Catherine A., Robert D. Rogers, George C. Hozier Jr., Kenneth G. Baker and Gerald Albaum (2007). Management of Marketing Research Projects: Does Delivery Method Matter Anymore in Survey Research? *Journal of Marketing Theory and Practice*, 15 (2), pp. 127-144.
39. Samaha, Stephen A., Robert W. Palmatier and Rajiv P. Dant (2011). Poisoning Relationships: Perceived Unfairness in Channels of Distribution, *Journal of Marketing*, 75, pp. 99-117.
40. Sanchez, Ron (1999). Modular Architectures in the Marketing Process, *Journal of Marketing*, 63, pp. 92-111.
41. Sen, Falguni and Michael Shiel (2006). From Business Process Outsourcing (BPO) to Knowledge Process Outsourcing (KPO): Some issues, *Human Systems Management*, 25, pp. 145-155.
42. Stremersch, Stefan, Allen M. Weiss, Benedict G.C. Dellaert and Ruud T. Frambach (2003). Buying Modular Systems in Technology-Intensive Markets, *Journal of Marketing Research*, 40, pp. 335-350.
43. Stump, Rodney L. and Jan B. Heide (1996). Controlling Supplier Opportunism in Industrial Relationship, *Journal of Marketing Research*, 33 (4), pp. 431-441.
44. Thelen, Shawn T., Boonghee Yoo and Vincent P. Magnini (2011). An Examination of Consumer Sentiment Toward Offshored Services, *Journal of the Academic Marketing Science*, 39, pp. 270-289.
45. Varadarajan, Rajan (2009). Outsourcing: Think more expansively, *Journal of Business Research*, 62, pp. 1165-1172.
46. Wathne, Kenneth H. and Jan B. Heide (2000). Opportunism in Interfirm Relationships: Forms, Outcomes, and Solutions, *Journal of Marketing*, 64 (4), pp. 36-51.
47. Williamson, Oliver E. (1975). *The Economic Institutions of Capitalism: Firms, Markets, Relational Contracting*, New York: The Free Press.
48. Williamson, Oliver E. (2010). Transaction Costs Economics: the Natural Progression, *The American Economic Review*, 100 (3), pp. 673-690.
49. Williamson, Oliver E. and Tarek Ghani (2012). Transaction Cost Economics and Its Uses in Marketing, *Journal of the Academy of Marketing Science*, 40, pp. 74-85.