

UDC 555.6

Velizar Vassilev

Technical University of Sofia, Bulgaria

## MEASUREMENT OF THE GUN-DRILL SHIFT IN THE PROCESSING OF LARGE HOLLOW SHAFTS

The large hollow shafts are essential machine elements with specific application. A significant technological problem is the shifting of the gun-drill during the processing of the hole. This paper refers to the measurement of the shift and the possibilities of affecting it.

**Keywords:** large hollow shafts, measurement, gun-drill shift.

### Introduction

The large hollow shafts are details with specific application and their manufacturing is related to numerous metrological and technological difficulties. One of them is the measurement of the gun-drill shift in the process of drilling, which requires the control of this shift during processing and the application of technological measures for its shut-off. This measurement is the main topic of the current paper.

### Measurement Scheme

The gun-drill shift can be determined by measuring the change of the thickness of the shaft during processing. The measurement scheme is shown on Fig. 1.

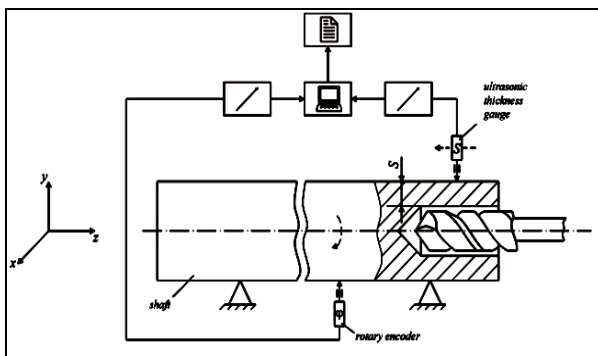

Fig. 1. Measurement Scheme

The measuring system consists of: ultrasonic thickness gauge, rotary encoder with position display unit, and computer.

When the shaft is positioned, the thickness  $S$  of the shaft is measured with an ultrasonic thickness gauge after the rotation of the shaft at an angle  $\alpha$ . The angle of rotation is measured with a rotary encoder. The two signals from the thickness gauge and from the rotary encoder are sent for processing to a computer with the use of specific software.

### Measurement Parameters

- Gun-drill shift –  $e$  (in a surface perpendicular to the  $z$  axis),  $e_x$  (projection in the  $XZ$  plane),  $e_y$  (projection in the  $YZ$  plane).
- Coaxiality deviation of the inner and outer rotating surfaces of the shaft –  $EPC$ .
- Sinusoidal deviation –  $EFS$ .

The sinusoidal deviation is the deviation of the thickness of the shaft in a definite section of the ideal sinusoid as a result of the deviation of the profile of the inner and outer rotating surfaces in the corresponding section.

### Measuring Procedure

The measuring procedure includes the following steps:

- 1 The shaft is positioned on the processing machine.
- 2 The shaft is marked in one longitudinal section (in a horizontal plane) and in  $n$  transversal sections  $z_j$ , ( $j = 1 - m$ ; see Fig. 2). In every transversal section,  $n$  equally distributed points are marked (ex.  $n = 16$  or  $n = 24$ ).

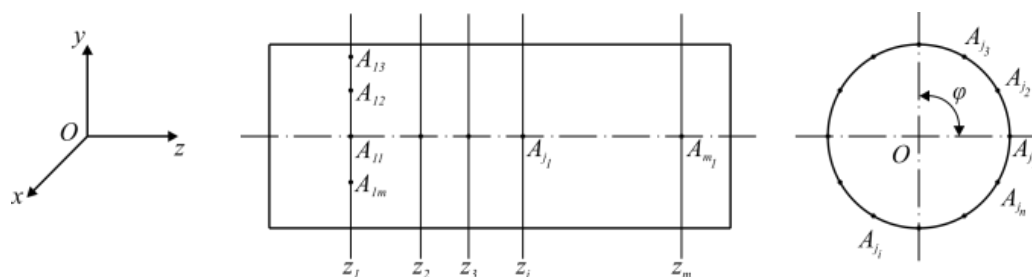

Fig. 2. Marking of the shaft

3 The rotary encoder is connected with the shaft in a random transversal section.

4 The ultrasonic thickness gauge is positioned for measurement on the first transversal section  $z_1$ , i.e. at point  $A_{11}$  situated on the marked horizontal line.

5 The indications of the rotary encoder are set to zero, i.e. the beginning of the polar coordinate system ( $u_1 = 0$ ) is determined (see Fig. 3 and Fig. 5) with the software (see Fig. 3 and Fig. 4).

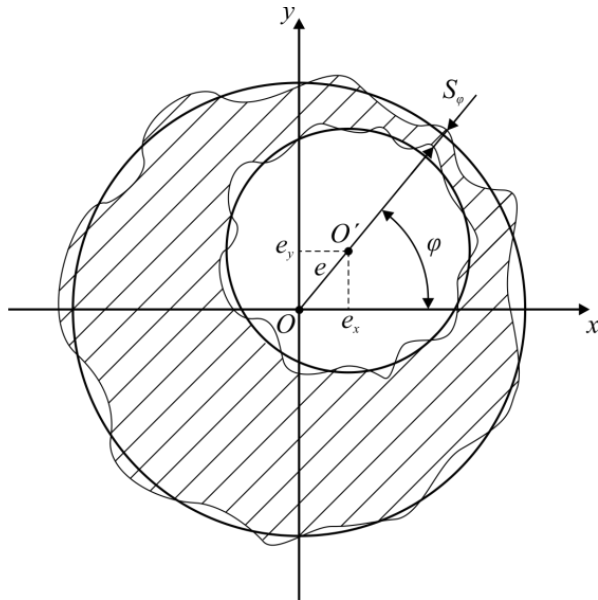

Fig. 3 Gun-drill shift

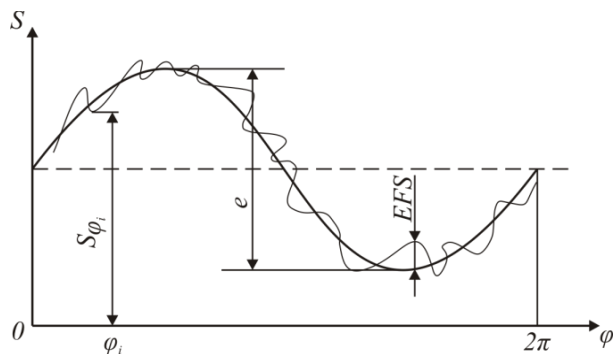

Fig. 4 Sinusoidal deviation

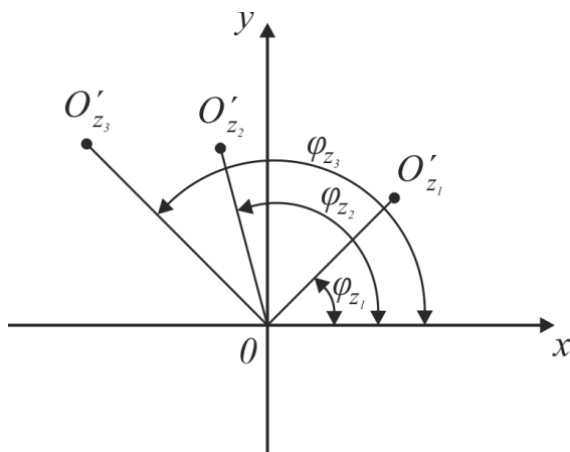

Fig. 5 Measurement of the gun-drill shift

6 The indications of the thickness gauge at point  $A_{11}$  are recorded.

7 The shaft is rotated and its thickness is measured at points  $A_{1j}$ .

8 The results are imported in the computer and the shift of the gun-drill  $e_1, e_{x1}, e_{y1}$  and the deviation from the sinusoid in the section  $z_1$  are determined

9 The same measuring procedure is repeated in the next  $j$  transversal sections, i.e. the thickness of the shaft at point  $A_{ji}$  is determined.

10 Using the results from the measurement of the shaft thickness at points  $A_{ji}$ , the parameters  $e_j, e_{xj}, e_{yj}, EFS_j, EPC_j$  are calculated.

11 The results are displayed in tables and graphs (see Fig. 3, 4, 5, and 6 and table 1).

### The results of a measurement in real conditions

The system for the measurement of the gun-drill shift in the processing of large hollow shafts is part of the mobile automated drawing-measurement complex “MARITZA”, developed for the needs of Novokramatorsky mashinostroitelny zavod (NKMZ). The complex is designed for measurement and control of large shafts and large hollow shafts (with length up to 20 m, diameter 1.8 m, and mass up to 50 t).

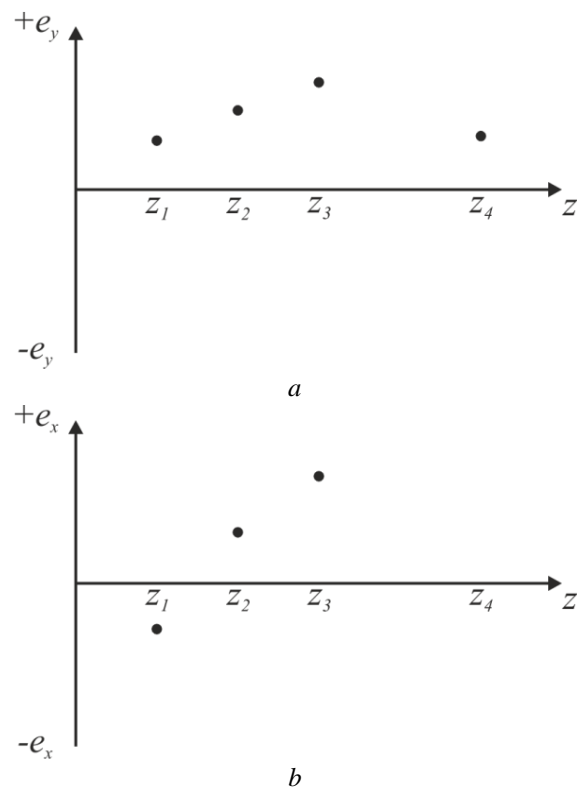

Fig. 6 The gun-drill shift in XZ and YZ planes

The testing of complex “MARITZA” at NKMZ confirms the high functional metrological potential of the complex (Новокраматорський машиностроитель-

ний завод. Производство валов и энергетического оборудования, Механический цех №5. Отчет о выполненной опытно-конструкторской работе разработка и испытание мобильного автоматизированного разметочно-измерительного цехового комплекса контроля параметров валов «МАРИЦА», 17.05.2010 г., г. Краматорск)

In table 1 and fig. 7, part of the measurement protocol of a hollow shaft, set on the processing machine 1001 in industrial unit 5 of NKMZ, is shown.

The shift of the gun drill in its three transversal sections is shown in table 1 and on fig. 7.

Table 1  
A part of the measurement protocol  
of a hollow shaft

Section j	1	2	3
$z_j$ [mm]	500	1000	1500
$e_{xj}$ [mm]	-0.59	-1.379	-1.734
$e_{yj}$ [mm]	0.504	-0.348	-1.482
$e_j$ [mm]	0.776	1.442	2.281
$\epsilon_j$ [°]	139.48	194.16	220.53

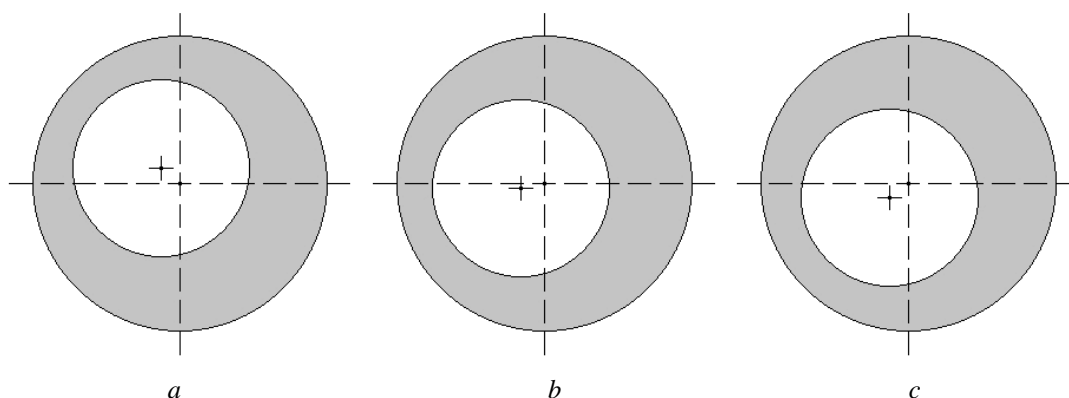

Fig. 7. A part of the measurement protocol of a hollow shaft:  
a – section 1; b – section 2; c – section 3

### Conclusion

1. A method and a system for the measurement of the gun-drill shift in the processing of large hollow shafts, as well as the non-coaxiality and the concentricity of the inner and outer rotary surfaces, are developed.

2. The testing of the system for the measurement of large hollow shafts at NKMZ, confirms the high f

unctional metrological potential of the measurement method and system.

Надійшла до редколегії 22.08.2011

**Рецензент:** д-р техн. наук, проф. Ю.П. Мачехин, Харківський національний університет радіоелектроніки, Харків, Україна.

### ВИМІРЮВАННЯ ПЕРЕМІЩЕННЯ СВЕРДЛА ПРИ ОБРОБЦІ ВЕЛИКОГАБАРИТНИХ ПОРОЖНІХ ВАЛІВ

Велизар Васильєв

Великогабаритні порожнисті вали є найважливішими елементами машинобудівних деталей спеціального призначення. Суттєвою технологічною проблемою є вимірювання переміщення свердла в процесі обробки отвору. У статті розглядається вимірювання переміщення свердла та впливаючі на нього фактори.

**Ключові слова:** великогабаритні порожнисті вали, вимірювання, переміщення свердла.

### ИЗМЕРЕНИЕ ПЕРЕМЕЩЕНИЯ СВЕРДЛА ПРИ ОБРАБОТКЕ КРУПНОГАБАРИТНЫХ ПОЛЫХ ВАЛОВ

Велизар Васильєв

Крупногабаритные полые вали являются важнейшими элементами машиностроительных деталей специального назначения. Существенной технологической проблемой является измерение перемещения свердла в процессе обработки отверстия. В статье рассматривается измерение перемещения свердла и влияющие на него факторы.

**Ключевые слова:** крупногабаритные полые вали, измерение, перемещение свердла.