

UDC 006/86:519

Z.L. Warsza<sup>1</sup>, A. Idzkowski<sup>2</sup>

<sup>1</sup>Industrial Institute of Control and Measurement, Warszawa, Poland

<sup>2</sup>Bialystok Technical University, Bialystok, Poland

## UNCONVENTIONAL DOUBLE OUTPUT BRIDGE FOR SIMULTANEOUS MEASUREMENT OF TWO PARAMETERS

*In this paper some interesting and unexpected features of unconventionally supplied a four-terminal (4T) bridge network are presented. DC current source is switched in parallel to opposite arms supply this circuit which can contain the differential sensor (connected in neighbor arms). This circuit of two simultaneous outputs from the both bridge diagonals is named as double current (2J) bridge. The output voltages are different functions of arm resistance increments and their values are given in absolute and relative units. As the example of application circuit with two sensors acting simultaneously as strain gauge and as RTD's is proposed. Signal conditioning formulas of two-parameter measurement of strain and temperature are discussed in detail. Some results obtained with the use of this bridge circuit are briefly described. This new type DC bridge is dedicated as the input analogue conditioning circuit of all type resistance sensors used in measurement and diagnostic systems applied in industry and other fields including gas and petrol installations.*

**Keywords:** bridge circuits, strain and temperature measurement, two-variable circuits.

### Introduction

The Wheatstone bridge has been a standard and most popular the resistance measurement circuit for over 160 years. Also the applications the newest analog-to-digital (ADC) converters and digital parts of measurement systems assure satisfying resolution, speed and universality due to programming facilities. At present, an improvement of strain, pressure, force, torque or other measurements depends mainly on metrological properties of the input analog part of these systems.

The sensor's thermal error (drift of sensor's offset and span) is compensated in the digital part of a conditioner by proper correction algorithms. For pressure measurement a piezoresistive sensor can be powered by an adjustable current source combined with a programmable-gain amplifier and external trim able resistors (e.g. MAX1450) [1], or two amplifiers and two digitally controlled potentiometers [2], or four digital-to-analog converters (DAC) resulting in a temperature-dependent bridge voltage (e.g. MAX1452) [3].

In a mass production of silicon piezoresistive-bridge pressure sensors, sensor-error correction is often affected by use of a laser or abrasive trimming machine, which trims resistors and thermistors in the signal conditioning circuit to the values required for offset and sensitivity compensation (e.g. in X-ducer piezoresistive pressure bridge-sensors [4], or NPC series of GE Novasensor pressure sensors [5]).

Apart from well-known instrumentation for the measurement of single variables, the development of methods of continuous indirect multivariable measurement is urgently needed. High accuracy measurement of increments of input immittances of multi-terminal cir-

cuit and of some quantities affecting them is an example.

Relevant problems have been considered on the example of two-parameter simultaneous measurement of resistance increments of the four-terminal (4T) network [6]. Since 1998 Warsza has been proposing two types of structures for such measurement and for the primary signal conditioning on the input analogue part of instrumentation channels. One is the circuit of two four-arm classic bridges connected in cascade [7]. The others of the unconventionally supplied 4T circuits are: supplied by two equal current sources in parallel to opposite arms – under acronym **2J** or in practice by two unequal sources between switching over these arms – **2x2J** or even only one switched source – **2x1J**. For all of these circuits Warsza proposed a common name: **double current bridges**. The circuits were described in [8], and more extensively in [9].

To illustrate this concept of simultaneous two-parameter measurement, either one-axis strain and temperature or two-axis strain using strain gauges plugged in a double current bridge, an experimental bridge-circuit was built. It can be competitive to the other solutions [1 – 3] and it has following advantages:

- there are two different output voltages depending on two measured quantities, i.e. strain and temperature;
- the temperature reading and compensation in whole measuring span is realized without any additional temperature sensor such as thermistor or thermistor-resistor parallel networks [4, 5].

Two output signals (representing temperature and strain) are interfaced to a microcontroller by ADCs.

The 2J bridge circuits and the cascade bridge circuit are applicable also for the GMR (*Giant Magneto-Resistive*) [11], and other impedance sensors. These circuits can compete successfully with an alternative idea of Pallas-Areny and collaborators [12]. It is indirect method based on detecting changes of resistances by measuring three times needed to discharge a given capacitor which is switched in turn to three nodes of the bridge circuit.

### 1. Unbalanced Double Current Bridge with Four Variable Arms

In this section the simple relations in the double current bridge (2J) introduced by Warsza [6] are described.

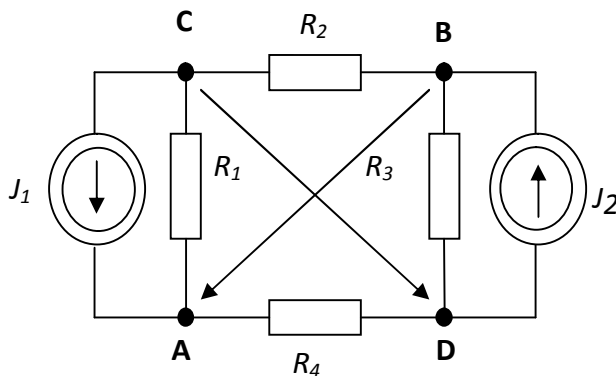

Fig. 1. The two output circuit supplied by two current sources  $J_1, J_2$  (introduced by Warsza on name 2J bridge [6]) with balance conditions:  
 $R_1R_2=R_3R_4$  for DC output  
 and  $R_1R_4=R_2R_3$  for AB output

The bridge shown in Fig. 1 is unconventionally supplied by two current sources  $J_1, J_2$  connected in parallel to opposite arms ( $R_1, R_3$ ) and has two outputs from diagonals A-B, D-C. Because of that it is named double current bridge. If two current sources  $J = J_1 = J_2$  are equal then the output voltages of the bridge of Fig. 1 are:

$$U_{DC} = J \frac{R_1R_2 - R_3R_4}{\sum R_i} = J \cdot t_{DC}(\varepsilon_i); \quad (1)$$

$$U_{AB} = J \frac{R_1R_4 - R_2R_3}{\sum R_i} = J \cdot t_{AB}(\varepsilon_i). \quad (2)$$

Where:  $\sum R_i = R_1 + R_2 + R_3 + R_4$ ,  $t_{DC}, t_{AB}$  – open-circuit voltage to current transmittances of DC and AB outputs.

The balance condition for the single output AB or DC is

$$U_{DC} = 0 \quad \text{if} \quad R_{10}R_{20} = R_{30}R_{40} \quad (1a)$$

or

$$U_{AB} = 0 \quad \text{if} \quad R_{10}R_{40} = R_{20}R_{30}. \quad (2a)$$

Where:  $R_i = R_{i0}(1 + \varepsilon_i)$ ,  $R_{i0}$  – the initial nominal

resistances.

If the current excitations are not equal, equations (1) and (2) have additional components which are dependent on the difference  $\Delta J$  [9]. Each output AB or DC is balanced for the equal products of resistances in its neighboring bridge arms. To fulfill both above conditions simultaneously for nominal initial values it is sufficient that

$$R_{10} = R_{30}, R_{20} = R_{40}.$$

After separation the relative resistance increments  $\varepsilon_i$  of the resistances  $R_i$  the formulas (1) and (2) are

$$U_{DC} = J \frac{R_{10}R_{20}(\varepsilon_1 + \varepsilon_2 - \varepsilon_3 - \varepsilon_4 + \varepsilon_1\varepsilon_2 - \varepsilon_3\varepsilon_4)}{\sum R_{i0} \left( 1 + \frac{\sum R_{i0}\varepsilon_i}{\sum R_{i0}} \right)} = T_{0DC} \cdot f_{DC}(\varepsilon_i); \quad (3)$$

$$U_{AB} = J \frac{R_{10}R_{20}(\varepsilon_1 - \varepsilon_2 - \varepsilon_3 + \varepsilon_4 + \varepsilon_1\varepsilon_4 - \varepsilon_2\varepsilon_3)}{\sum R_{i0} \left( 1 + \frac{\sum R_{i0}\varepsilon_i}{\sum R_{i0}} \right)} = T_{0AB} \cdot f_{AB}(\varepsilon_i). \quad (4)$$

Where:  $\varepsilon_i$  – the relative changes of resistances  $R_i$  from  $R_{i0}$ ;  $T_{0DC} = T_{0AB} = T_0$  – initial voltage sensitivities of circuits;  $f_{DC}(\varepsilon_i), f_{AB}(\varepsilon_i)$  – their imbalance functions.

Assume that sensors are in all arms of the bridge and their resistance changes are small, then  $\varepsilon_i\varepsilon_j \ll \varepsilon_i + \varepsilon_j$  and . Thus the equations can be simplified as follows

$$U_{DC} = J \frac{R_{10}R_{20}(\varepsilon_1 + \varepsilon_2 - \varepsilon_3 - \varepsilon_4)}{\sum R_{i0}} = T_0(\varepsilon_1 + \varepsilon_2 - \varepsilon_3 - \varepsilon_4); \quad (5)$$

$$U_{AB} = J \frac{R_{10}R_{20}(\varepsilon_1 - \varepsilon_2 - \varepsilon_3 + \varepsilon_4)}{\sum R_{i0}} = T_0(\varepsilon_1 - \varepsilon_2 - \varepsilon_3 + \varepsilon_4). \quad (6)$$

For i.e.  $J_1 = J_2 = 0.02 \text{ A}$ ;  $\varepsilon_1 = \varepsilon_2 = 0.1$ ;  $\varepsilon_2 = -\varepsilon_4 = 0.02$  and  $R_{10} = R_{30} = 1 \text{ k}\Omega$ ;  $R_{20} = R_{40} = 120 \Omega$ , the differences between voltage values received from (3) and (5) or (4) and (6) do not exceed 10%.

It is easy to notice that voltages  $U_{DC}, U_{AB}$  equally depend on relative changes  $(\varepsilon_1 - \varepsilon_2)$ , and with inverse sign on  $(\varepsilon_2 - \varepsilon_4)$ . In papers [6] and [9] another method to measure all separate arm increments (or decrements) of 4R bridge is given. Example of 2J bridge-circuit application for 2-parameter measurement is presented in the next sections.

### 2. 2J Bridge with Two Active Arms

The bridge on Fig 2 is supplied by single current source  $J$  switched over to the opposite arms. Then each

of the output voltages is held, summed up in two cycles (the superposition theorem) and measured. Such a supply does not cause the aforesaid problem of the different excitation currents. It ensures a compensation of thermoelectric voltages (of equal opposite values between output terminals) and the independence of the current  $J$  direction.

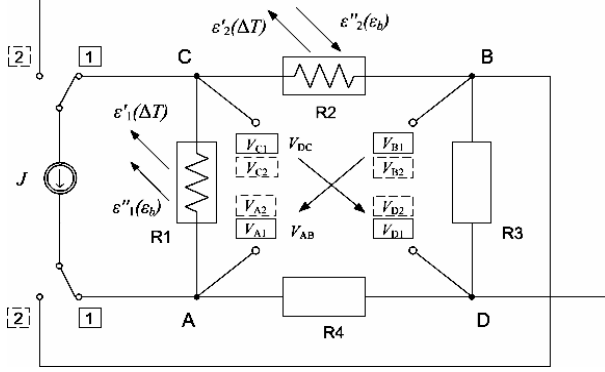

Fig. 2. Double current bridge circuit supplied by single switched source  $J$  for temperature  $\Delta T$  and bending strain  $\varepsilon$  measurements

Assuming that there are only two sensors in adjoining arms, the resistances of others are:  $R_3 = R_{30}$ ,  $R_4 = R_{40}$  (which is tantamount to  $\varepsilon_3 = \varepsilon_4 = 0$ ).

If modules of the values  $|\varepsilon_1|$ ,  $|\varepsilon_2|$  are small enough, equations (5), (6) are simplified to:

$$U_{DC} = T_0(\varepsilon_1 + \varepsilon_2); \quad (7)$$

$$U_{AB} = T_0(\varepsilon_1 - \varepsilon_2). \quad (8)$$

Where:  $T_0 = J \frac{R_{10}R_{20}}{2(R_{10} + R_{20})}$  – the initial voltage sensitivity is equal for both outputs.

The first output voltage is proportional to the sum and the other one to the difference of increments.

### 3. Example of Strain and Temperature Measurement

The 4T structure of the 2J bridge circuit is applied to one-axis strain and temperature measurement. The placement of two strain gauges A and B on the beam is shown in Fig. 3.

The right end of this beam is loaded, the left one is supported.

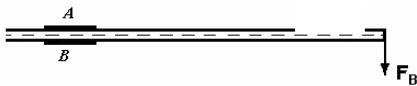

Fig. 3. One-axis strain measurement, A, B – strain gauges,  $F_B$  – bending force

The changes in resistance of strain gauges consist of two parts:  $\varepsilon_1 = \varepsilon' + \varepsilon''$ ,  $\varepsilon_2 = \varepsilon' - \varepsilon''$ , respectively. One part is increment due to temperature (9), the other one is

the increment (or decrement) due to mechanical stress (10). If there are two strain gauges of the same type, the relative increments in temperature are of the same value and of the same sign. Because the first gauge A is stretched (Fig. 2) and the other B compressed in the same time then the increments due to mechanical stress are of the opposite signs.

$$\varepsilon'_1(\Delta T) = \varepsilon'_2(\Delta T) = \varepsilon'; \quad (9)$$

$$\varepsilon'_1(\varepsilon_b) = -\varepsilon'_2(\varepsilon_b) = \varepsilon''. \quad (10)$$

From (7) and (8)

$$U_{DC} = T_0(\varepsilon' + \varepsilon''); \quad U_{AB} = T_0(\varepsilon'' - \varepsilon'). \quad (11)$$

Changes could be considered as linear for both measured quantities, i.e.:

$$\varepsilon'(\Delta T) = K_1 \cdot \alpha_T \cdot \Delta T;$$

$$\varepsilon''(\varepsilon_b) = K_2 \cdot k \cdot \varepsilon_b.$$

Where:  $\alpha_T$  – the temperature coefficient of gauge's resistance,  $\Delta T$  – change of temperature,  $k = k_0(1 + \alpha_K \Delta T)$  – strain gauge factor,  $\varepsilon_b$  – bending strain,  $K_1$ ,  $K_2$  – coefficients depend on parameters of measuring circuit (current value and initial resistances of strain gauges).

After substitution, both functions are as follows:

$$\varepsilon' = K_1 \cdot \alpha_T \cdot \Delta T = \frac{U_{DC}}{2T_0} = \frac{U_{DC}(\sum R_{i0})}{2JR_{10}R_{20}};$$

$$\varepsilon'' = K_2 \cdot k \cdot \varepsilon_b = U_{AB} / (2T_0) = (U_{AB}(\sum R_{i0})) / (2JR_{10}R_{20})$$

and

$$\Delta T = \frac{U_{DC}(\sum R_{i0})}{2JR_{10}R_{20}\alpha_T K_1} = \frac{\varepsilon_1 + \varepsilon_2}{2\alpha_T K_1}; \quad (12)$$

$$\varepsilon_b = \frac{U_{AB}(\sum R_{i0})}{2JR_{10}R_{20}kK_2} = \frac{\varepsilon_1 - \varepsilon_2}{2kK_2}. \quad (13)$$

The both measured quantities depend linearly and separately on the output voltages  $U_{AB}$  and  $U_{CD}$ , supplying current  $J$  and the parameters of the gauges. Such an advantage of this circuit is difficult to achieve in other DC bridges [12, 13].

### 4. Description of the Experiment

The conclusion presented above has been verified experimentally. The switched current source was applied to achieve  $J_1 = J_2$ . It was constructed (Fig. 4) with the use of LM317 and four MOSFET switches, which have low on-resistance  $R_{ON} = 0.06 \Omega$ . The current excitation can be manually adjustable from 9 mA to 38 mA. Transistors work in pairs – two switched on and two switched off at the same time. Their work is controlled by Atmega16 microcontroller port. The output voltages  $U_{AB}$  and  $U_{DC}$  are connected to 24-bit sigma-delta ADC via post-conditioning module. ADC assures  $\approx 0.3 \mu V$  resolution when reference voltages are +2.5 V and

-2.5 V. Input range is from -2.56V to +2.56 V. Post conditioning module consists of two instrumentation amplifiers AD620AN. The voltages are processed by the microcontroller Atmega16.

As shown in Fig. 4, as opposed to other publications [14], the temperature and strain measurement is carried out together only by single differential strain gage sensor and the separate circuit with an RTD (Resistance Temperature Device) or thermocouples are not used. The bridge circuit has 4 terminals, each gauge is

connected in 2 terminals way, and load cell may have a cable with 8 wires.

In strain measurements with the use of classical bridge 4-wire or 6-wire connection with Kelvin sensing is a standard. 4-wire current supply and 4-wire output cabling in this circuit effects that there is no Kelvin sensing and it is not needed.

The experiment has been performed for two values of temperature (22 °C and 65 °C) of a beam while the beam was being bent by a micrometer screw (Fig. 5).

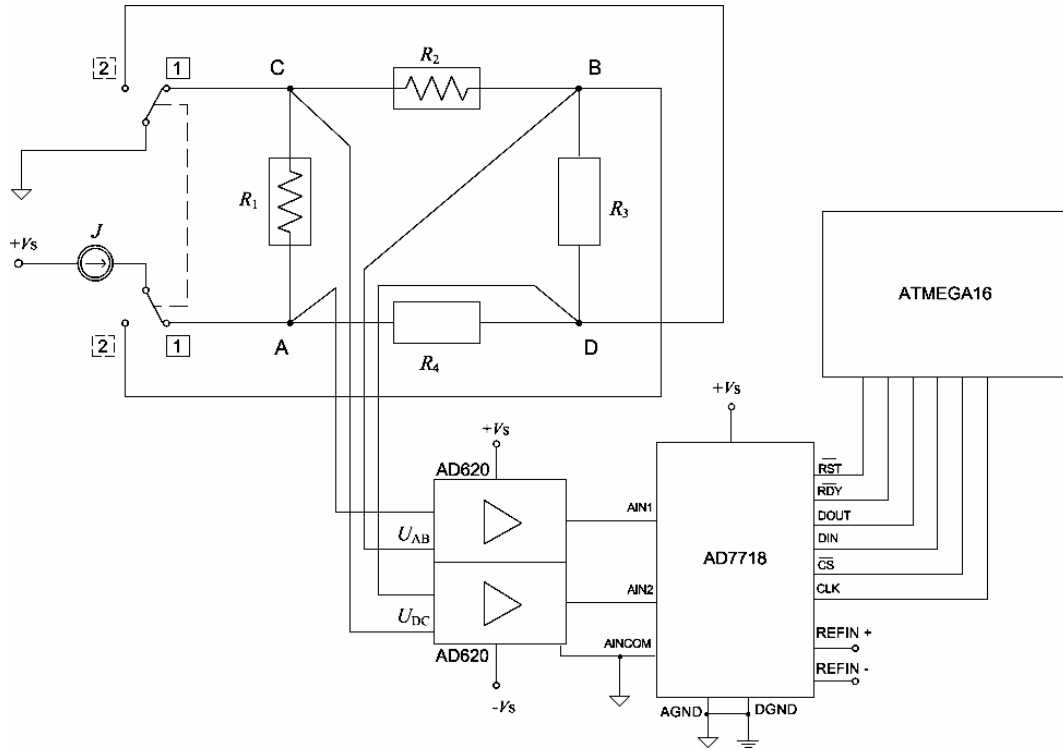

Fig. 4. Transducer system of double current bridge for measurement of strain and temperature

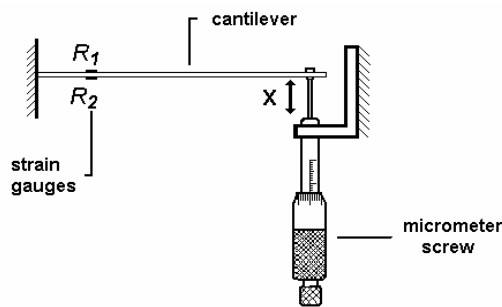

Fig. 5. Laboratory stand (the cantilever had rectangle cross-section, width  $b = 20$  mm, height  $h = 0.8$  mm, length  $L = 200$  mm, the distance between strain gauges and the place of force fixing  $l = 180$  mm, Young's modulus  $E = 2.1 \cdot 10^{11}$  N/m<sup>2</sup>)

### 5. Experimental Results

The results of the experiment are shown in Fig. 6 – 8. They present the bending strains  $\epsilon_b$  and the temperature values in response to the beam X deflection.

The theoretical values of bending strains are received from the dependences presented below. In this

experiment and theoretical calculations the following values of parameters have been applied

$$\alpha_T = 0.04 \cdot 10^{-3} \text{ deg}^{-1}, k = 2.15. \quad (14)$$

For rectangular cross section the maximum deflection is

$$X = \frac{F \cdot L^3}{3E \cdot I_x}. \quad (15)$$

Where: F – force acting on the tip of the beam; L – length of the beam; E – modulus of elasticity;  $I_x$  – area moment of inertia.

Area moment of inertia of a cantilever (weightless) beam is

$$I_x = \frac{b \cdot h^3}{12}. \quad (16)$$

Where: b – width, h – height of a beam's cross section.

The dependence between bending strain and the acting force is

$$\epsilon_b = \frac{6 \cdot F \cdot L}{b \cdot h^2 \cdot E}. \quad (17)$$

For geometrical parameters of used cantilever it follows that

$$\varepsilon_b = \frac{3 \cdot h \cdot X}{2 \cdot L^2} = 30 \cdot X(\mu D). \quad (18)$$

The experiment results are completely in accord with theory.

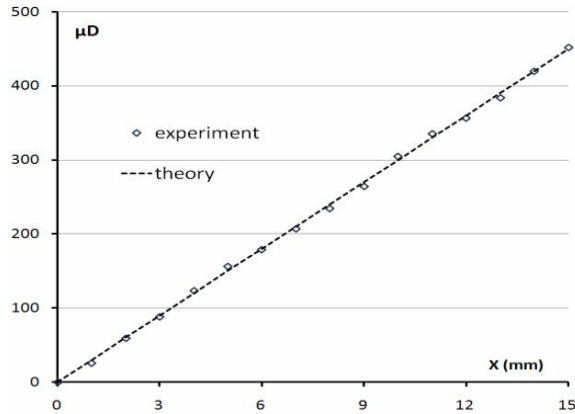

Fig. 6. Relative increments in bending strain  $\varepsilon_b$  in term of the beam deflection X for  $\Delta T \approx 0$  ( $\mu\text{strain} = \mu D$ )

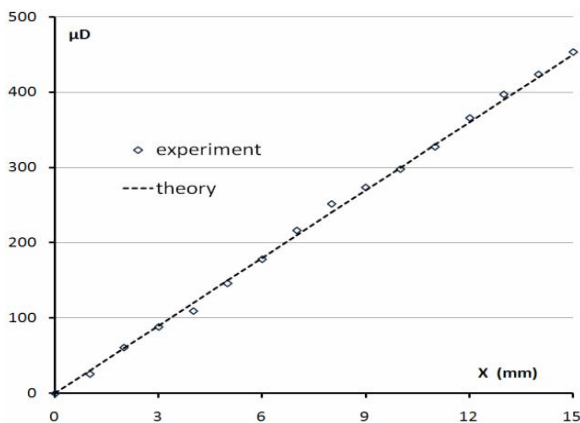

Fig. 7. Relative increments in bending strain  $\varepsilon_b$  in term of the beam deflection X for  $\Delta T = 40^\circ\text{C}$

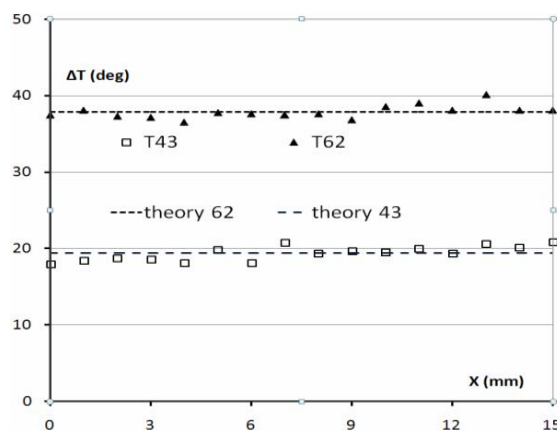

Fig. 8. The measured change of temperature in term of the beam deflection X for  $T_0 = 23^\circ\text{C}$  and  $\Delta T \approx 20^\circ\text{C}, 38^\circ\text{C}$  (adequately)

The nonlinearity error with respect to mechanical stress has maximum value 1.4% FSR and 0.2% FSR in average.

In this case the nonlinearity error with respect to mechanical stress has maximum value 2.5% FSR and 0.2% FSR in average. There is a slender influence of temperature change on these characteristics. This circuit does not require any additional temperature compensation.

The changes of temperature are calculated from equation (12). Only the temperature coefficient of gauge's resistance is considered. Other temperature influences are neglected. In Fig. 8 the measured changes of temperature are presented together with expected theoretical results. For this measurement the maximum error of nonlinearity is a little higher – 5% FS (1.0% FS – average).

## Conclusions

The unconventional 2J bridge measures simultaneously the mechanical stress and the real change of temperature of strain gauges in their localization. The innovation of this method consists in a particular supplying by current sources and in measuring the voltages on two diagonals. The main advantage is that this circuit does not require any additional circuit of temperature compensation as signals from both diagonals can be processed on the digital part of the measurement system.

The maximum nonlinearity error with respect to mechanical stress is 2.5% and to changes in temperature is 5%. These values are acceptable for many industrial applications.

However some additional experimental tests are still predicted.

Furthermore this kind of bridge sensors will be applied also for semiconductor strain gauges which are more sensitive to stress and temperature.

The 2J bridge circuits could be also implemented to design different types of MEMS sensors. It will be the aim of further work by the authors.

## Acknowledgments

This work has been done within the framework of the project N N505 263735 financed by Ministry of Science and Higher Education of Poland in the years 2008-2010.

## References

1. "MAX1450, low cost 1%-accurate signal conditioner for piezoresistive sensors", Maxim product data sheet.
2. "Sensor circuits and digitally controlled potentiometers", Intersil application note AN135, 2005.
3. "Sensor temperature compensation using the four DAC signal conditioning architecture", Maxim application note 1839, 2002.

4. Swartz C., Derrington C., Gragg J., "Temperature Compensation Methods For The Motorola X-ducer Pressure-Sensor Element", Motorola Semiconductor application notes.

5. "NPC-1210 series medium pressure sensor", Product data sheet of GE NovaSensor Inc.

6. Warsza Z.L. Bridges Supplied by Two Current Sources—New Tool for Impedance Measurements and Signal Conditioning / Z.L. Warsza // Proc. of IMEKO-TC-7 Symposium. — Cracow (Poland), 2002. — P. 231-236.

7. Warsza Z.L. Backgrounds of two variable (2D) measurements of resistance increments by bridge cascade circuit / Z.L. Warsza // Proc. of SPIE vol. 6347 part 2, 63472R, 2006.

8. Warsza Z.L. Two Parameter (2D) Measurements in Four Terminal (4T) Impedance Bridges as the New Tool for Signal Conditioning part 1 and 2 / Z.L. Warsza // Proc. of the 14th International Symposium on New Technologies in Measurement and Instrumentation and 10th Workshop of IMEKO TC-4. — Gdynia/Jurata 2005. — P. 31-42.

9. Warsza Z.L. Two Parameter (2D) Measurements in Double — current Supply Four-terminal Resistance Circuits / Z.L. Warsza // Metrology and Measurement Systems. — Polish Academy of Science, 2006. — Vol. XIII, no 1. — P. 49-65.

10. Idzkowski A. Application of Double Current Bridge-Circuit for Simultaneous Measurements of Strain and Temperature / A. Idzkowski, J. Makal, Z.L. Warsza // IEEE Instrumentation, Measurement and Technology Conference, (IMTC 2007). — Warsaw, Poland, May 2007. — P. 1-4.

11. Sifuentes E., Casas O., Pallas-Areny R., "Direct Interface for Magnetoresistive Sensors", IMTC 2007 Conference Proceedings, #7386.

12. Jordana J. A simple efficient interface circuit for piezoresistance pressure sensors / J. Jordana, R. Pallas-Areny // Sensors and Actuators A-Physical. — 2006. — Vol. 127, Issue 1, 28. — P. 69-73.

13. Sydenham P.H., Thorn (eds) R., Handbook of Measuring System Design, John Wiley & Sons, Chapter 126: "Electrical Bridge Circuits — Basic Information" by Z. L. Warsza, pp. 867–877, New York 2005.

14. Parker A.R. Simultaneous Measurement of Temperature and Strain Using Four Connecting Wires, NASA Technical Memorandum 104271, 1993.

Надійшла до редколегії 10.01.2012

**Рецензент:** д-р техн. наук, проф. И.П. Захаров, Харьковский национальный университет радиоэлектроники, Харьков, Украина.

### НЕТРАДИЦІЙНІ МОСТИ З ДВОМА ВИХОДАМИ ДЛЯ ОДНОЧАСНОГО ВИМІРЮВАННЯ ДВОХ ПАРАМЕТРІВ

З.Л. Варша, А. Ідсковскій

В даній роботі представлено кілька цікавих і несподіваних особливостей нестандартно живленої чотирьохполюсної (4Т) мостової схеми. Джерело постійного струму ввімкнено в паралельні протилежним плечам живлення цієї схеми, яка може містити диференціальні датчики (підключені до сусідніх плечей). Ця схема двох одночасних виходів з обох діагоналей моста названа двострумним (2J) мостом. Вихідні напруги є диференціальними функціями збільшення опору плечей і їх значення наведені в абсолютних і відносних одиницях. У якості прикладу пропонується застосування схеми з двома датчиками, що діють одночасно, такими як тензодатчик і резистивний датчик температури. Детально обговорюються формули формування двох сигналів вимірювання параметрів напруги і температури. Коротко описані деякі результати, отримані з використанням цієї схеми моста. Цей новий тип моста постійного струму призначений як схема узгодження аналогового входу для всіх типів резистивних датчиків, що використовуються в діагностичних вимірюваннях і систем, що застосовуються в промисловості та інших областях, включаючи газові і бензинові установки.

**Ключові слова:** мостові схеми, вимірювання деформації і температури, біваріантні схеми.

### НЕТРАДИЦИОННЫЕ МОСТЫ С ДВУМЯ ВЫХОДАМИ ДЛЯ ОДНОВРЕМЕННОГО ИЗМЕРЕНИЯ ДВУХ ПАРАМЕТРОВ

З.Л. Варша, А. Идсковский

В данной работе представлено несколько интересных и неожиданных особенностей нестандартно запитанной четырехполюсной (4Т) мостовой схемы. Источник постоянного тока включен в параллельные противоположным плечам питания этой схемы, которая может содержать дифференциальные датчики (подключенные к соседним плечам). Эта схема двух одновременных выходов с обеих диагоналей моста названа двухтоковым (2J) мостом. Выходные напряжения являются дифференциальными функциями приращения сопротивления плечей и их значения приведены в абсолютных и относительных единицах. В качестве примера предлагается применение схемы с двумя датчиками, действующими одновременно, такими как тензодатчик и резистивный датчик температуры. Подробно обсуждаются формулы формирования двух сигналов измерения параметров напряжения и температуры. Кратко описаны некоторые результаты, полученные с использованием этой схемы моста. Этот новый тип моста постоянного тока предназначен как схема согласования аналогового входа для всех типов резистивных датчиков, используемых в диагностических измерениях и систем, применяемых в промышленности и других областях, включая газовые и бензиновые установки.

**Ключевые слова:** мостовые схемы, измерение деформации и температуры, бивариантные схемы.