

Запобігання та ліквідація надзвичайних ситуацій

UDC 629.52.7

Al-Tameemi Raheem Qasim Naser, Lami Dheyaa Juhi Hussein

State ecological Academy of postgraduate education and management, Kyiv

SCIENTIFIC SUBSTANTIATION OF CIRCUIT SOLUTIONS OF CREATION A FUNCTIONAL STABLE COMPLEXES WITH THE US OF ENVIRONMENTAL MONITORING WITH USAGE OF PSEUDO SATELLITE TECHNOLOGIES

In the article, methodology of improving functional stability board information and control systems available vehicles are considered. The proposed models, methods and tools for automating the process control ergatic innovative systems of transport. At a time when increases the risk of critical (crisis) situations caused by the actions of environmental factors and threatening accidents and disasters, they provide security functional stability in a single space-time continuum.

Keywords: *traffic safety, functional stability, automation technology.*

Introduction

Functional stability (FS) difficult engineering systems should function in hazardous environment. Their high cost and potential risks of environment require a non-traditional supplying of the appropriate level of reliability, survivability and safety critical application.

Paradigms based on repeated reserving, introduction of the systems of self test and elements with increased level of reliability are known. Unfortunately, it worsens technical and economical specifications of ergatic innovative systems (EIS). In the event of extreme dangerous situations, traditional methods do not lead to the desired reduction in accident rate. Necessity of introduction of significant hardware redundancy for supplying of survivability and reliability of EIS became a basic limitation of this approach without whilst active timely role of automated intelligent information technologies (IIT) on the transport.

The purpose of given article is the technique of decision by the means of artificial intellect on increase of functional stability of on-board information-controlling complexes which on the criteria of accident-free of trajectory movement, at occurrence of failure (emergency situation) includes three phases: identification, making a decision, realization of supplying of functional stability of movement of maneuverable vehicle in action of factors of influence of environment, but with qualities of a safe navigation area.

Basic material

The first phase of the technique depends on degree of accuracy of display of the risk of crisis situation for bringing to the attention of EIS in the conditions of diffi-

cult dynamic systems. The model which filters noise, interferences, indignation, forms attracting condition of the situation display, at once attracts the attention of the EIS. Those are failures which are followed brightly by expressed changes of the spatial situation regarding initial and is predicted to safe path of a maneuverable vehicle in space-time continuum of difficult dynamic system.

Failures with a hidden attracting effect which introduce lateness to the active, timely role of intelligent information technologies, are defined only by the way of complex procedures of comparison of the conditions of a few, previously forming, measuring, computational entrance channels of on-board information-controlling complex. Identification of particular modes of failures is defined by presence of control systems of databases [1]. Information technology is branched out at the absence of knowledges of further future consequences from the occurrence of ambiguity and growth of the risks of impact of approach of emergency events.

The second stage of the methodology - to activate the onboard information and control complex for the new criteria guaranteed adaptive control where images are stored, the standards for a variety of threats, disturbances, noise inherent in a critical situation. Active perception of the reference signs of failures in their space-time development actualizes qualitative image-primary standard and in on-board information-controlling complex, making a decision takes place regarding the type of emergency situation [2]. If, on any signs, image-primary standard does not develop, then computing system of on-board information-controlling complex continues search - comparison - synthesis of the model of the observer, until finalizes by the decision of configuration - made situation.. Offered construction of on-

board information-controlling complex is necessary that identification of crisis situation was in due time finalizes in a real (and possibly accelerated) time scale. Only then, against a background of dynamic changes performance by choosing variety of maneuvers of vehicle is implemented.

The third stage in the functional stability of the onboard information and control complex, classified under emergency situations, is to implement timely anti-crisis measures on the basis of a logical chain

$$\langle \text{if } \{ i \in I \text{ situation} \} \Rightarrow \text{then } f_i \in F_1 \rangle,$$

in order to prevent unwanted models previously accumulated threats and consequences of disturbance. Increase of stability and creation of the conditions for dependable automated means of critical application straight depends on construction of qualitative information through communications to each cause-effect circuit of specialized support service of decision on accident precaution and accidents [3].

The principal cause of emergency losses of functional stability of known traditional means in non regular, not diagnosed situations - is unavailability of obsolete subsystems of on-board information-controlling complexes to emergency actions in unforeseen crisis conditions of uneven development of threatening events.

Step 1 methodology. The work proposed computational functional stability of the onboard information and control complex at the stage of identifying any current emergency situation involves the execution of such rapid and major operations:

- measurements of deviations of actual dependable adaptive parameters of movement of maneuverable vehicles from given (reference), which formalize a practical experience of ITS;
- classification of the most likely model to which the state of denial;
- updating the full image situational failure and effective trouble-free solution;
- implementation, according to the criteria of safety of life adopted by the forecast of the most plausible solutions based on the model-reference image (from an accurate reflection of the situation) and causal action without damaging the ecology of the environment, the economy breakeven flight maneuvering of vehicles on a given route and time schedule simulation transport work [4].

Step 2: Control and complex diagnostics of identified emergency situations.

Each sequential changeover of the condition of off-line situations in on-board information-controlling complex displays specifically dynamic model which we describe by an expendable uneven parameter vector $\gamma(k)$. These events occur at random times, probabilistic characteristics are not known in advance. Parameter vector $\gamma(k)$ characterizes parameterized and structural

ordered properties of the operating mode of on-board information-controlling complex, which is synchronized with the time of vital activity of difficult dynamic system (dynamics of transients).

Step 3. Decomposition algebraization real situations of on-board information-controlling complex in three sub phases.

Establishment of the fact of the appearance and the detection of failure. Fixed time and the signal "Crash" with explanations (see Fig. 1 and refinement: where, what, when, as it happened).

2. Localization and definition diagnosed qualities of failure. The circle of the space and the source of failure is defined (in information-measuring, computational, energy parts of difficult dynamic system).

3. An estimate of the variation of the parameter with respect to a reference. Establish the extent of damage is, the components of the onboard information and control complex. Identify ways to target their further use (possibly degraded). Such evaluation formalize procedures by the way of introduction to on-board information-controlling complex of compensating amendments of restoring control, including iterative selection of more effective observer on robustness criterion to disagreements between real and calculated evaluations of parameters of a difficult dynamic system.

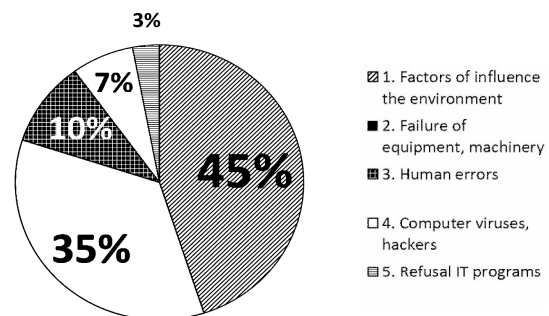

Fig. 1. The example of preliminary distribution of the type of traffic safety threats factors on a confidence level of 10^{-7} hour⁻¹

Step 4. Formalizing, in certain circumstances, rational interaction, the task of preventing emergency situations given the board information and control complex. Unified on equation invariant patterns accurately forecast the state to the next step, which is described in the form of functional dependence

$$X(k+1) = F\{X(k), U(k), W(k)\gamma(k)V_1(m_1), V_2(m_2), \dots, V_N(m_N)\}, \quad (1)$$

where vector $\gamma(k)$ depends on unevenly varied parameters N , size gallop of i - parameter V_i and the time of its occurrence $m_i, i = \overline{1, N}$ are unknown size.

In the equation, observations onboard information and control complex may also include all of these parameters, which abruptly, situational and accidentally changed:

$$Y(k) = h\{X(k), U(k), V(k)\gamma[K, V_1(m_1), V_2(m_2), \dots, V_N(m_N)]\} \quad (2)$$

In each instant of time of current step of the simulation of difficult dynamic system additionally one parameter for simplification of algorithm in the system of support of decision can change.

Step 5. Linguistics of intelligent information technologies of the systems of support of decision and structural models allows:

- to establish the fact of the appearance of the jump - change "working" normalized states;
- define (identify) the number and priority of the estimated parameter;
- estimate the parameters $V_i \quad \forall i = \overline{1, n}$, like value of detected jump;

- compare the state vector $X(k)$ and the accuracy of its forecast $X(k+1)$.

Each operation of the subsystem of support of decision on the class of tasks realizes (Fig. 2) a joint evaluating of non-stationary parameters and conditions of on-board information-controlling complex. Equal mathematical description and a linguistic visualization, any off-line situations, we form by the way of introduction of unevenly varied components of the vector of condition of a difficult dynamic system [5].

Step 6. Block-modules functionally stable on-board information and control systems, along with bilateral actors communication interfaces, coordinate data of direct and inverse problems of dynamics within a single system model of terminal control.

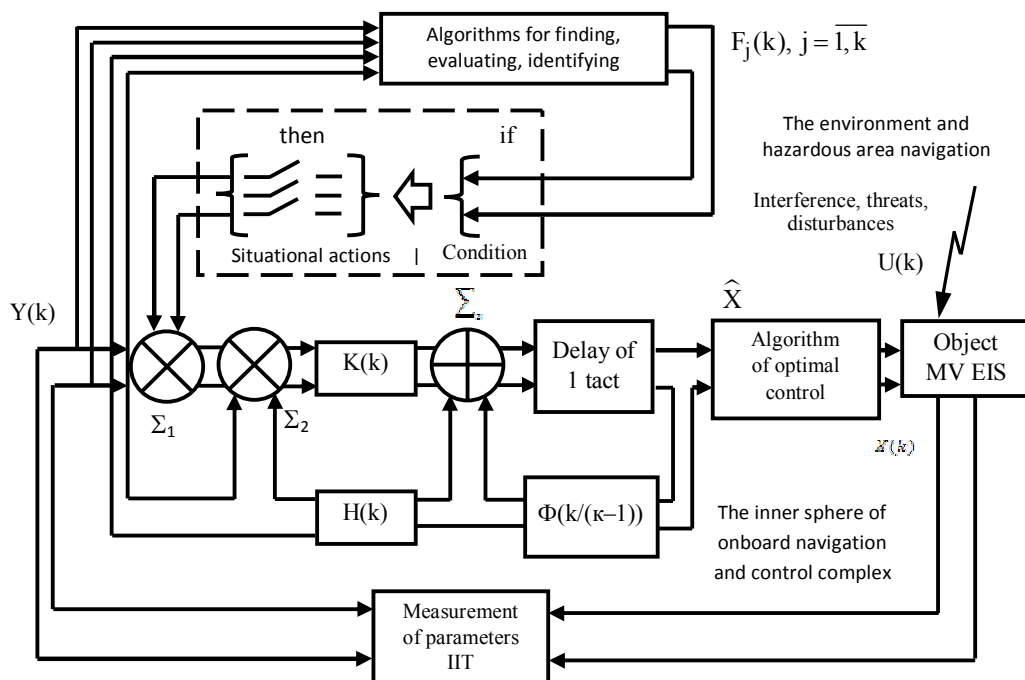

Fig. 2. Structural implementation of the proposed detection technology - the identification of failures in-vehicle information and control systems

Known typical module supply functions, in which it is necessary to support outgoing signal (mode) of the controlled device on the same constant level (stabilization task); to provide observation of specifying the impact (tracking task) of the variable unknown beforehand. In perturbing, transient conditions of work of controlled devices, innovative adaptive modules calculate at first desired law of augmented changeover of the controlled process (prognosis pulsing movement), but only then synthesized program control law is realized. These modules guaranteed of adaptive control of maneuverable vehicles realize, in the conditions of crisis occurrence of emergency situations, an accurate or approximate positioning in a safe navigation area. Quick implementation of process of trouble-free movement of maneuverable vehicles to terminal trajectory supplies a functional stability, survivability, failure-safety and reli-

ability of the subsystems, complexes and the components of difficult dynamic systems [6].

Step 7. Specification of the current situation and the current terminal trajectory.

1. Removal of disagreements and contradictions, when condition substantially is different from desired program. Conflict is an unforeseen emergency situation as determined in the initial moment between description of initial indignation and occurrence at stage real movement in the conditions of impact of the external environment.

2. The co-ordination of parameters of the controlled device with their evaluations which are determined pursuant to equations for the particular parameterized indignation of the current situation.

3. Quasi-optimal decision on the operating mode of on-board information-controlling complex, move-

ment of maneuverable vehicles and indignation, if they, on maximum distance between the participants of a difficult dynamic system, have been not yet entirely classified.

If the control system is not capable to be adapted automatically to existing external conditions, as well as two inside, caused by failures of on-board equipment, then, to contradiction to planned program, the risk of a dangerous movement of maneuverable vehicle sharply grows. If the purpose of control (movement to program trouble-free trajectory), at such indistinct, guaranteed conditions of safety of the Li, is not reached, then threat exists to turn out in a dangerous area of navigation instead of safe navigation area [7].

Then classical methods of construction of the systems of traditional control of programs motion bring nearer break-down. For the moment of occurrence of crisis situations a series of existing properties of controlled object and the conditions of his functioning are not known beforehand. An active search of these knowledges is minimal requirements for timely synthesis of the law guaranteed of adaptive control, only on the basis of definition of return dynamics task. Then, during movement of maneuverable vehicles, due to information-program observers, a real decrease in the level of indefinite and random components in phase coordinates of condition of interaction of components of a difficult dynamic system arises.

Step 8. Formalization of the task of compulsory stabilization on purpose-oriented prognosis trajectory of a safe area of navigation on the criteria of trouble-free movement in the conditions of impact of indefinite situation in space-time continuum of difficult dynamic system.

Controlled object, condition of which corresponds instant of time X, we describe by the vector function $X(t) = [X_1(t), \dots, X_n(t)]$. Components $X_i(t)$, $i = \overline{1, n}$ in creating the phase coordinates and n - and measured Euclidean space R^n points X - n a space of states of a dynamic system.

We equal dynamics of movement of maneuverable vehicle, as particular, controlled in time, object (using invariant law), for example, matrix differential equation:

$$\begin{aligned} \dot{X}(t) &= F[X(t), U(t), Z(t)] + P(t); \\ X(t_0) &= X_0, \quad t \in [t_0, t_T], \end{aligned} \quad (3)$$

where $U(t)$ - m-measurable vector control actions; $Z(t)$ - r-measurable parameter vector object that responds to the impact of various environmental factors; $P(t)$ - n-measurable vector of external disturbances; X_0 - a similar condition; $T = t_T - t_0$ - the burden in the motion of the object within the frame changes through guaranteed adaptive management.

To parameters of control and condition of the object given limitations of safe navigation zone:

$$X(t) \in Q_X; U(t) \in Q_U. \quad (4)$$

Constant supervision and monitoring of zones of space-time continuum allows to receive the evaluations of real risks and to enter changes to the parameters of the vectors of terminal conditions. At time intervals $[t_0, t_T]$ control function $U(t)$ time-continuous and may, due to switching, branching at isolated points have discontinuities of the first kind.

Parameter value ξ_i unknown, only limited plenty $Q_\xi = \{\Xi\}$ of admissible values of parameter ξ_i is given.

$$\Xi(t) = [\xi_1(t), \xi_2(t), \dots, \xi_r(t)]. \quad (5)$$

By unknown external indignation can be and external indignation which constantly act $P(t)$ and their probability properties. This is due to the fact that the perturbations are treated as unobservable and immeasurable. Regarding indignation $P(t)$ it is known that $P(t) \in Q_p$ for all $t \in [t_0, t_T]$, where Q_p - given physical plenty on the planning stage of this route.

The aim is to provide a terminal control the movement of the object within the safe navigation area on a given conditional standard motion path by an appropriate choice $U(t) \in Q_u$.

The decision of these equations produces the admissible terminal control $U(t) \in Q_u$, which generates $X_n(t)$ the program of the object to respond to all kinds of perturbations and control.

Task formulated by E.A. Barbashin, allows to define a purpose-oriented program control $U_n(t)$ and trajectory produced by it $X_p(t)$, which are optimum $U_n^0(t)$, $X_n^0(t)$ in the conditions of a safe area of navigation and minimum of the given (on vector convolution) functional quality

$$J[U_n^0(\cdot), X_n^0(\cdot)] = \min J[U_n(\cdot), X_n(\cdot)]. \quad (6)$$

Step 9: Implementation of the resulting general algorithm to ensure trouble-free movement maneuverable vehicles. Depending on the conditions of threatening situation and control system optimization requirements by functioning of the object, we decide one of three basic tasks:

- stabilization terminal programmed motion with best speed in a safe navigation area;
- terminal control pursuant to the nearest safe navigation zones and dangerous navigation areas;
- tracking for guaranteed safe distance up to the largest risk of events.

Unified standard laws of operating control in clearly specified types of the risks, in the conditions of action of factors of perturbing environment are always realized (Fig. 2) by present blocks-modules of functional stability of on-board information-controlling

complexes. According to steps 6, 9, for li safety assurance, is passed the control to performance of local transients. On each sequential interval it emerges accidentally and short-term acts, up to maintenance from perturbing route zones of movement of maneuverable vehicles, in local space-time continuum, situational change (co-ordination of serial realization of three of above-mentioned) of the laws of control which allows continuously to prevent approach to dangerous (risky) zones and constantly to be in a safe zone without the risks of breakdowns and accidents due to dependable adaptive on-board information-controlling complex that realizes a functional stability.

Findings

Offered technique supplies an implementation as on-board information-controlling complexes ensuring the level of traffic safety of maneuverable vehicles in extreme conditions. She is different from known by structural self-organizing algorithms and self reconfiguration interaction between modules active to adequately situational factors of influence on environment to the movement of maneuverable vehicles. The model of the module of "functional stability" in the cases of development of critical off-line situations in a real of the time is formalized, when adequate decisions about emergency measures of counteraction as a sequential set of controlling impacts directed to minimize losses of resources, maximizations of ratings of quality and efficiency of the safe movement of maneuverable vehicles are formed. Methods and the facility are offered which, in emergency situations, actively and increase in due time a functional stability of on-board information-controlling complexes of vehicles.

References

1. Машков О.А. Особенности разработки системы мобильного экологического мониторинга техногенных

систем с использованием космических технологий / О.А. Машков, Р.К.Н. Аль-Тамими, Д.Д.Х. Лами // V-й Всеукраїнський з'їзд екологів з міжнародною участю (Екологія/ Ecology-2015), 23-26 вересня, 2015. Збірник наукових праць. – Вінниця: ТОВ «Нілан-ЛТД», 2015. – С. 110.

2. Баранов Г.Л. Особливості побудови алгоритму керування в позовжньому русі кутом тангажу на основі рішення зворотної задачі динаміки / Г.Л. Баранов, О.А. Машков, В.Р. Косенко // Інтелектуальні системи прийняття рішень та проблеми обчислювального інтелекту ISDMCI'2011: Збірка наукових праць у двох томах. – Т. 1. – Євпаторія, 2011. – С. 414-422.

3. Машков О.А. Синтез функціонально-стійкої системи керування рухомим об'єктом із заданими динамічними властивостями / О.А. Машков, В.Р. Косенко // Збірник наукових праць. – К.: Інститут проблем моделювання в енергетиці НАН України, 2011. – Вип. 60. – С. 186-214.

4. Машков О.А. Проблеми створення функціонально стійкої автоматизованої системи управління рухомих об'єктів / О.А. Машков, В.Р. Косенко // Інтелектуальні системи прийняття рішень та проблеми обчислювального інтелекту ISDMCI'2012: Збірка наукових праць. – Євпаторія, 2012. – С. 497-508.

5. Баранов Г.Л. Критерії діагностування в функціонально стійких системах управління / Г.Л. Баранов, О.А. Машков, В.Р. Косенко // Інтелектуальні системи прийняття рішень та проблеми обчислювального інтелекту ISDMCI'2013: Збірка наукових праць. – Євпаторія, 2013. – С. 61-65.

6. Баранов Г.Л. Синтез структури складної системи на основі методів ранжування показників якості / Г.Л. Баранов, О.А. Машков, В.Р. Косенко // Інтелектуальні системи прийняття рішень та проблеми обчислювального інтелекту ISDMCI'2014: Збірка наукових праць. – Херсон: ХНТУ, 2014. – С. 108-114.

7. Машков О.А. Застосування інформаційних аерокосмічних технологій для оцінки транскордонних екологічних конфліктів / О.А. Машков, Р.К.Н. Аль-Тамими, Д.Д.Х. Лами // Інформаційні процеси, технології та системи на транспорті. – К.: НТУ, 2015. – № 3. – С. 136-147.

Надійшла до редколегії 15.01.2016

Рецензент: д-р техн. наук, проф. О.А. Машков, Державна екологічна академія післядипломної освіти та управління, Київ.

НАУКОВЕ ОБҐРУНТУВАННЯ СХЕМНИХ РІШЕНЬ СТВОРЕННЯ ФУНКЦІОНАЛЬНО СТІЙКИХ КОМПЛЕКСІВ ЕКОЛОГІЧНОГО КОНТРОЛЮ З ВИКОРИСТАННЯМ ПСЕВДОСПУТНИКОВИХ ТЕХНОЛОГІЙ

Аль-Тамімі Рахім Касім Насер, Ламі Діа Джухі Хуссейн

У статті викладена методика підвищення функціональної стійкості проходження інформації для засобів контролю та управління існуючих систем. Запропоновані моделі, методи та засоби автоматизації процесу управління інноваційних ергатичних систем руху. У той час, коли підвищується ризик розвитку критичних (кризових) ситуацій, викликаних діями екологічних факторів і загрозливих аварій і катастроф, вони забезпечують безпеку і функціональну стійкість в єдиному просторово-часовому континуумі.

Ключові слова: безпека руху, функціональна стійкість, технологія автоматизації.

НАУЧНОЕ ОБОСНОВАНИЕ СХЕМНЫХ РЕШЕНИЙ СОЗДАНИЯ ФУНКЦИОНАЛЬНО УСТОЙЧИВЫХ КОМПЛЕКСОВ ЭКОЛОГИЧЕСКОГО КОНТРОЛЯ С ИСПОЛЬЗОВАНИЕМ ПСЕВДОСПУТНИКОВЫХ ТЕХНОЛОГИЙ

Аль-Тамими Рахим Касим Насер, Лами Диа Джухи Хуссейн

В статье изложена методика повышения функциональной устойчивости прохождения информации для средств контроля и управления существующих систем. Предложенные модели, методы и средства автоматизации процесса управления инновационных эргатических систем движения. В то время, когда повышается риск развития критических (кризисных) ситуациях, вызванных действиями экологических факторов и угрожающих аварией и катастроф, они обеспечивают безопасность и функциональную устойчивость в едином пространственно-временном континууме.

Ключевые слова: безопасность движения, функциональная устойчивость, технология автоматизации.