

B. Gorkunov, S. Lvov, Y. Borysenko

*National technical university "Kharkiv polytechnic institute", Kharkiv*

## UNCERTAINTY ESTIMATION WHILE PROCEEDING MULTI-PARAMETER EDDY CURRENT TESTING

*The article deals with the problem of non-destructive testing of metal products and shows the advantage of the multiparameter eddy current method, which allows, to determine the conductivity and magnetic permeability of tested object in addition to defects detection. The design and operation description of an eddy-current transducer using spatially periodic decomposition of the electromagnetic field is presented. A mathematical apparatus that allows the inverse task solution, namely to determine the parameters of the object being tested is described. A graph-analytical method for estimating the standard uncertainty of determining the parameters of a controlled object is presented, and its use is justified.*

**Keywords:** *nondestructive multi-parameter eddy-current testing, spatially-periodic decomposition of electromagnetic field.*

### Introduction

**Problem statement.** Eddy current measuring transducers are widely used in solving problems of non-destructive testing (NDT), in particular, in defect-detection and structure-scanning. The eddy current NDT method is based on the analysis of the electromagnetic field generated by eddy currents flowing in a controlled metal object. Physically, the eddy current transducer (ECT) is a transformer with one excitation wire and several measuring wires. A key-feature of the eddy current method is the possibility of its use in multi-parameter testing, and this approach is often the only one that can identify the material of the metal object under test (OUT) or detect its stress-strain state. Specific conductivity  $\sigma$ , magnetic permeability  $\mu$  and product radius  $d$  are considered to be parameters of the OUT. Also, the state of the structure of OUT can be studied while estimating object's stress or strain. Multi-parameter testing allows definition of the electromagnetic parameters of the studied sample by processing the parameters of a series of electromagnetic field spatial harmonics, according to certain algorithm. Anyway, the question of the reliability of described testing is also important. Namely what are the values of uncertainties of measured quantities. Due to the fact that observed algorithm assumes indirect measurements without an explicitly given measurement equation, the solution to the problem of estimating uncertainty is also of certain practical interest.

**The analysis of recent researches and publications.** Among the competing methods of multi-parameter NDT electro-potential, eddy current magnetic multi-frequency eddy current and pulsed eddy current should be mentioned [1–2]. Eddy-current magnetic method is used to reduce the effect of magnetic permeability and increase the depth of penetration by using a constant magnetic field. To achieve the greatest effi-

ciency of such a method, it is necessary to optimize the operating frequency of the electromagnetic field also the bias current value should be selected depending on the type of controlled metal so that measurements would be taken at the saturation threshold of the material.

Electric potential method is mainly used to control large-sized objects. Significant current (up to tens of kA) is passed through the controlled object and both surface and subsurface defects are detected by the distribution of the electric potential across the product. The electro-potential method is complicated because of need for significant currents. Eddy current magnetic method requires an accurate adjustment of the bias current for studying certain material [2].

Pulsed eddy current method implies the use of a probing signal with a wide spectrum for example of rectangular shape [3]. A wide spectrum allows the use of indirect method to determine the frequency-dependent parameters of the OUT, usually conductivity and magnetic permeability. Due to the dependence on the intensity of the influence of magnetic permeability and conductivity on frequency, the analysis of the spectrum of the measuring winding signal allows us to indirectly determine these parameters. However, the absence of a well-developed algorithm for processing the spectral components of the signal of the measuring winding hinders the widespread introduction of this method [4].

In case of multi-frequency eddy current method, it should be considered that as the frequency changes, the maximum current density will shift to another layer of object's material, where, due to structural heterogeneity, material's properties may be different. The influence of the skin effect on the result of the product diameter measurement due to the influence of roughness may also be significant [5–6]. Moreover, mentioned methods are mainly used for defects detection and they usually aren't

suitable for structure or type of material study. Defects detection tasks are in some kind of way simpler than determining the composition and structure of a material, since the defect's emerging in the sensing zone leads to a drastic change in the output signal of the transducer.

**Purpose of the article.** So, the universality of the eddy current testing method necessitates elaboration of the mathematical description of the electromagnetic field picture arising in the "ECT – OUT" system. Availability of this model and normalized transformation functions give an opportunity to solve the task of identifying an unknown object by analysis of the electromagnetic field reaction to its occurrence.

It is possible to identify the ferromagnetic material from which the OUT is made of by such characteristic features as magnetic permeability  $\mu$  and specific conductivity  $\sigma$  taking into account the geometric parameter. In addition, the influencing factors are anisotropy of the material and the structure of its crystal lattice, which can be influenced by internal stresses arising in the process of casting and mechanical processing of the sample. With such initial data, it should be spoken about solving the problem of multi-parameter testing. It is obvious that the more parameters are subjects to control, the more measured parameters should be collected from the output signal.

When solving problems of multi-parameter testing, it is convenient to implement the model of spatially periodic field structure to expand the number of controlled parameters of the product [7]. According to this model, the measuring windings can be placed in such a way that it is possible to get information about parameters of several spatial harmonics. In this case, amplitudes and phases of each spatial harmonic are, in general, independent informative parameters. The algorithm for spatial field harmonics parameters determination is described in [8]. The task of determining the parameters of a cylindrical metal sample is studied below.

**Exposition of basic material**

Suppose there is a ferromagnetic cylinder 6 (fig. 1) of radius  $a$ , which is located in an electro-magnetic field created by excitation wire (EW) 1 that is placed at a distance  $d$  from the sample's axis.

A sinusoidal current of density  $J$  flows in the conductor 1 in the direction coinciding with the positive direction of the  $z$  axis. The longitudinal axis  $z$  of the sample is the center of a circle of radius  $r$ , along which measuring wires (MW) 2, 3, 4, 5 are located. The position of each wire is described by the angular coordinate measured from wire 1.

In order to eliminate edge effects longitudinal length of MWs is made 10–20% less than one of EW. This construction allows making an assumption of electromagnetic field homogeneity.

For such spatial model in [7–8] expressions for the  $r$ -th and  $n$ -th components of the magnetic field inside

and outside a cylindrical product were obtained. Those expressions allows to represent these components as an expansion in Fourier series by spatial harmonics taking into account the angular pole widths  $\gamma$ :

$$H_r(r, \varphi, t) = e^{i\omega t} j \sum_n \frac{\sin(n\gamma)}{n\gamma} f_n(r) \sin(n\varphi); \tag{1}$$

$$H_\phi(r, \varphi, t) = e^{i\omega t} j \sum_n \frac{\sin(n\gamma)}{n\gamma} g_n(r) \cos(n\varphi),$$

where  $n$  – spatial harmonic number;  $\omega = 2\pi f$  – excitation field frequency;  $f_n$  and  $g_n$  – distribution functions for sine and cosine components of corresponding spatial harmonics of electromagnetic field.

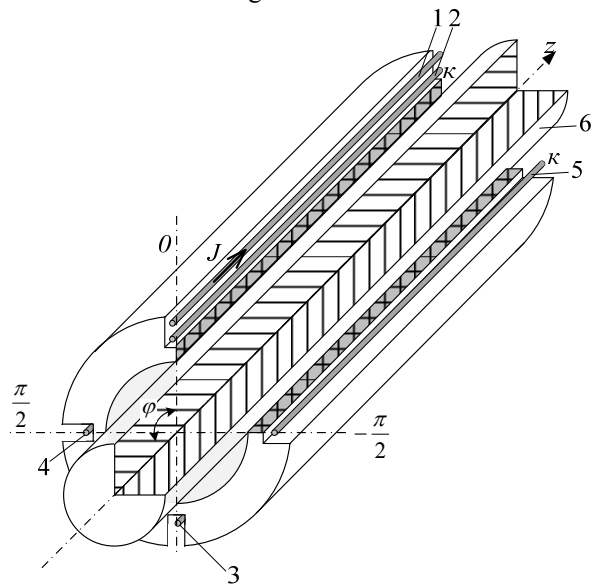

Fig. 1. Mutual arrangement of the metal cylinder, measuring and excitation wires

Fig. 2 shows the spatial pattern of the field when first two harmonics of Fourier series are considered and depicts measuring and excitation wires location.

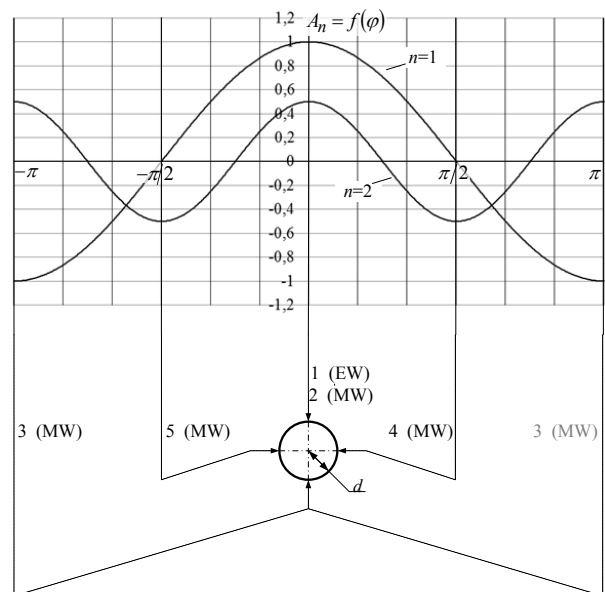

Fig. 2. First and second spatial harmonics of electromagnetic field

To acquire the amplitudes of spatial harmonics, it is necessary to perform the measurement procedure without OUT. To distinguish the amplitude  $E_{10}$  of the first spatial harmonic, measuring wires 2 and 3 need to be connected in series in subtractive polarity. To distinguish second spatial harmonic  $E_{20}$ , measuring wires 4 and 5 need to be connected in series in additive polarity. Then OUT (cylindrical sample) is placed into the transducer, the amplitudes of the spatial harmonics  $E_1$  and  $E_2$  are again determined using the algorithm described above, and the angle of the first spatial harmonic relative to the current of the EW is measured with a phase-shift meter. It is important to keep the same value of current density  $J$  in the EW in case of sample's presence and absence.

Next, the normalized amplitude of the first and second spatial harmonics is determined as the ratios

$$A_1 = \frac{E_1}{E_{10}}, \quad A_2 = \frac{E_2}{E_{20}}.$$

To determine the sample's parameters, it is necessary to obtain theoretical dependences for the first and second spatial harmonics. [9–10]. System of equations (1) has a solution for functions  $f_n$  and  $g_n$ , which after distinguishing real and imaginary components of Bessel function, by the means of *ber* and *bei* Kelvin functions allow us to obtain formulas for amplitudes and phase shifts of  $i$ -th spatial harmonic. As for practical applying it is advisable to perform EMF normalization as the ratio of EMFs values with and without inspected product. Such normalization let us to eliminate field dissymmetry and difference in wires parameters. Consequently we can get expressions to determine theoretical values of normalized amplitudes of  $n$ -th spatial harmonic

$$A_n = \left(\frac{a}{d}\right)^n \sqrt{(\operatorname{Re}(f_n))^2 + (\operatorname{Im}(f_n))^2} \quad (2)$$

and its phase shift

$$\operatorname{tg}(\Phi_n) = \frac{\operatorname{Im}(f_n)}{\operatorname{Re}(f_n)}, \quad (3)$$

where

$$\operatorname{Re} f_n = \frac{a_n^{(+)}(\mu a_n^{(+)} + a_n^{(-)}) + b_n^{(+)}(\mu b_n^{(+)} + b_n^{(-)})}{(\mu a_n^{(+)} + a_n^{(-)})^2 + (\mu b_n^{(+)} + b_n^{(-)})^2}$$

$$\operatorname{Im} f_n = \frac{-a_n^{(+)}(\mu b_n^{(+)} + b_n^{(-)}) + b_n^{(+)}(\mu a_n^{(+)} + a_n^{(-)})}{(\mu a_n^{(+)} + a_n^{(-)})^2 + (\mu b_n^{(+)} + b_n^{(-)})^2}$$

$$a_n^{(+)} = \operatorname{ber}_{n-1}x + \operatorname{ber}_{n+1}x; \quad a_n^{(-)} = \operatorname{ber}_{n-1}x - \operatorname{ber}_{n+1}x;$$

$$b_n^{(+)} = \operatorname{bei}_{n-1}x + \operatorname{bei}_{n+1}x; \quad b_n^{(-)} = \operatorname{bei}_{n-1}x - \operatorname{bei}_{n+1}x.$$

While deriving these expressions the variable  $x$  was introduced, which is the function of initial quantities:

$$x = a\sqrt{\mu_0\mu\sigma\omega}. \quad (4)$$

If there is a structure change or a flaw in controlled zone owing to measurement of several parameters (spatial harmonics amplitudes and phase shifts) mentioned issues could be identified more reliably.

Universal functions application leads to reverse task solving that lies in determining electromagnetic and geometric parameters of studied sample.

Reverse task algorithm is following. Basing on the knowledge of spatially-periodic field structure (fig. 2) MW and EW are placed in certain way, that allows to get amplitude and phase shift of the first spatial harmonic from the output signal. After these amplitudes normalization we will get opportunity to compose expression for universal amplitude determination –

$$A_{21} = \frac{A_2}{(A_1)^2}.$$

Utilizing known from [7–8] theoretical dependencies for  $A_{21} = f(\operatorname{tg}\Phi_1)$  (fig. 3, a) with the use of previously measured values  $A_2$ ,  $A_1$  and  $\operatorname{tg}\Phi_1$  it is possible to define the value of magnetic permeability  $\mu$ .

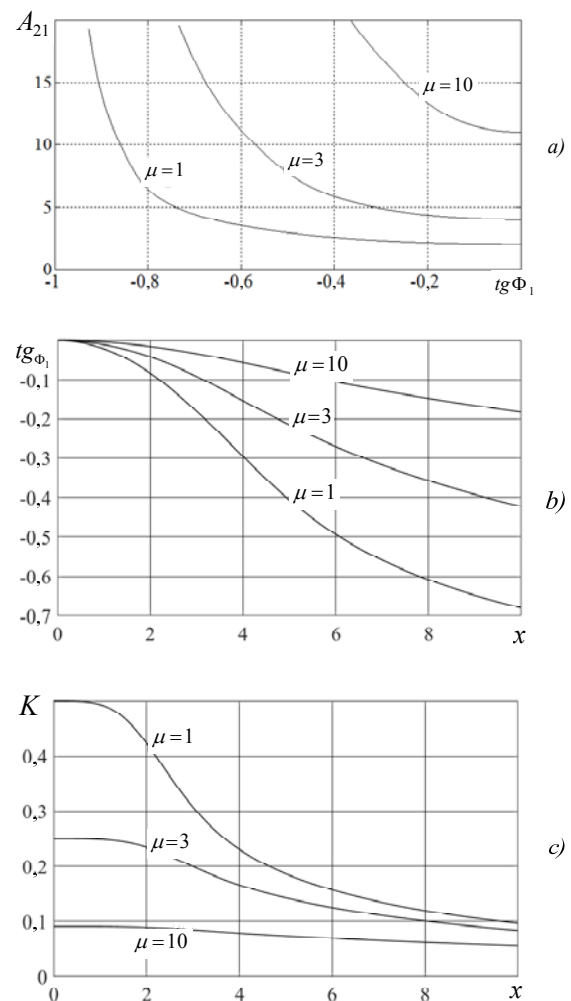

Fig. 3. Theoretical dependencies to determine the parameters of the sample

Utilizing known from [7–8] theoretical dependencies for  $\text{tg}\Phi_1 = f(x)$  (fig. 3, b) with the use of measured value of  $\text{tg}\Phi_1$  and defined on the previous stage value of  $\mu$  we define a value of  $x$ . In some occasions the value of diameter  $a$  of OUT can be unknown, in that case for  $\sigma$  determination the value of diameter should be defined at first. This can be done with the use of known theoretical dependencies  $K = f(x)$  (fig. 3, c) by the expression

$$a = A_1 \frac{d}{K} \tag{5}$$

And after that from

$$\sigma = \frac{x^2}{a^2 \mu_0 \mu_r \omega} \tag{6}$$

the value of specific conductivity can be defined. This in the end gives us the values of  $\mu$  and  $\sigma$  and these parameters could be used to distinguish the type of material of OUT.

Due to mathematical complexity of described algorithm it seems difficult to proceed standard uncertainty calculation after classical approach. According to this approach in order to calculate standard uncertainty type b the functional relationship that connects measurand and measured quantities should be given explicitly. Described algorithm for determining  $\mu$  and  $\sigma$  supposes indirect measurements whose uncertainty accordingly to GUM should be estimated with the use of partial derivatives of quantities, included in that functional relationship and those quantities should contribute significantly to the value of the measurand. And if in case of determining  $\sigma$  and  $a$  required functional relationships are given (eq. 5–6) there is no such relationship for  $\mu$  uncertainty determination.

The paper proposes discussion of graphical way of uncertainty value estimation which essence is illustrated by the example of magnetic permeability uncertainty calculation. Fig. 4, a, b shows graphical dependencies of magnetic permeability as a function upon arguments  $A_{21}$  and  $\text{tg}\Phi_1$ . Let's suppose the values of  $A_{21m1}$  and  $\text{tg}\Phi_{1m1}$  and corresponding uncertainties were obtained while studying some OUT. It is proposed to compare two ways of uncertainty calculation. The first one supposes that uncertainty value can be estimated as a length of a diagonal of a rectangular area of uncertainty spans overlapping (the diagonal lies on the line 1) (fig. 4, a, b). The second one supposes that uncertainty value can be estimated as a segment length of a line 2 that is perpendicular to the tangent to the curve  $\mu = f(A_{21}, \text{tg}\Phi_1)$  in the point with coordinates  $(A_{21m1}; \text{tg}\Phi_{1m1})$  and this segment lies inside the area of uncertainty spans overlapping. Fig. 4a, b illustrates straight 1 and 2 for areas with different curve steepness.

To determine lengths of mentioned segments it is proposed to use approximation method that assumes

magnetic permeability values definition, which corresponds to the segment ends of straight 1 (fig. 4, a). To approximate  $\mu = f(l)$  dependence (where  $l$  is coordinate over an axis with known values of  $l$  for  $\mu = 1$ ,  $\mu = 3$  and  $\mu = 10$ ). Fig. 5 shows the example of  $\mu$  determination.

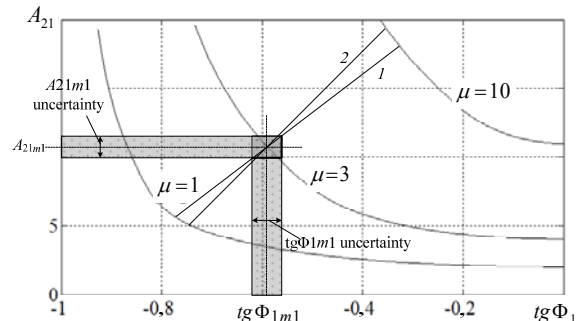

a)

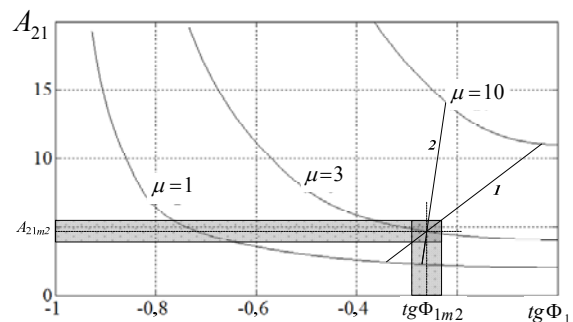

b)

Fig. 4. Ways of uncertainty estimation for the areas with different steepness of  $\mu = f(A_{21}, \text{tg}\Phi_1)$  curve

Margins for the uncertainty for the point  $(A_{21m1}; \text{tg}\Phi_{1m1})$  calculated for the segment of straight 1 accordingly to the method described is  $\pm 0,52$  and for the segment of straight 2 is  $\pm 0,43$ ; as for the point  $(A_{21m2}; \text{tg}\Phi_{1m2})$  values are  $\pm 0,8$  и  $\pm 0,6$  respectively.

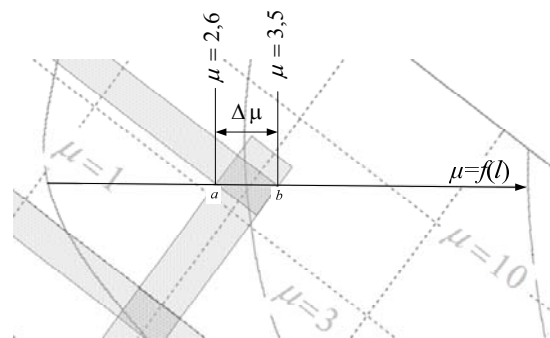

Fig. 5. Example of graphical method of uncertainty calculation

Fig. 6 shows curves for  $\mu = f(A_{21}, \text{tg}\Phi_1)$  for the values of  $\mu$  which corresponds to the calculated values of uncertainty margins.

Footnotes on fig. 6 show in what way one or the other curve was obtained (i. e. curve  $4a_1$  is for segment of straight 1 of the 4a figure and so forth).

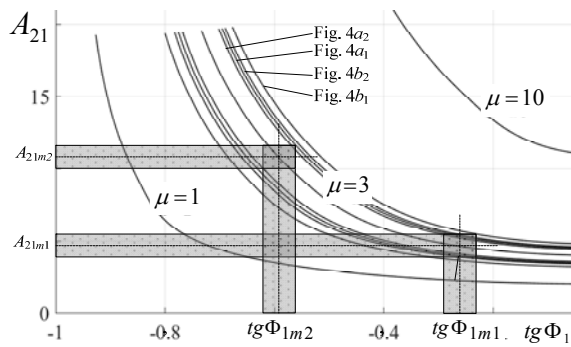

Fig. 6. Magnetic permeability curves corresponding to its calculated uncertainty values

### Conclusion

In the result of research has been made it is possible to assert that obtained with the use of graph-analytical way values of standard uncertainty with enough exactness characterize the area of OUT mag-

netic permeability dispersion. Authors of this research has developed mathematical apparatus allowing to calculate magnetic permeability as the function  $\mu = f(A_{21}, \text{tg}\Phi_1)$ . This apparatus allows to calculate magnetic permeability values intrinsic to maximum permissible error of measurement instruments used (voltmeter and phase shift meter) then maximum difference of calculated magnetic permeability values gives us its dispersion (uncertainty). But in certain circumstances proposed graph-analytical method would be the only one that allows estimating uncertainty, especially if there is only graphic data available and there is no mathematical apparatus to calculate  $\mu$  value. Given algorithm of measurement performing and proposed structure of the transducer allows determining geometrical and electromagnetic parameters of metal cylindrical sample being tested. Advantage of proposed algorithm and transducer is capability of simultaneous measuring of three OUT parameters and presumes contactless testing of cylindrical metal samples.

### Список літератури

1. Ключев В.В. Измерения, контроль, испытания и диагностика / В.В. Ключев. – М.: Машиностроение, 1996. – 464 с.
2. Ключев С.В. Комбинированные методы вихрекового, магнитного и электропотенциального контроля / С.В. Ключев, П.Н. Шкатов, В.В. Ключев. – М.: Спектр, 2011. – 190 с.
3. García-Martín J. Non-Destructive Techniques Based on Eddy Current Testing / J. García-Martín, J. Gómez-Gil, E. Vázquez-Sánchez // *Sensors*. – 2011. – No. 11. – P. 2525-2565. <https://doi.org/10.3390/s110302525>.
4. Electromagnetic and eddy current NDT: a review / A. Sophian, G.Y. Tian, D. Taylor, J. Rudlin // *Insight*. – May 2001. – Vol. 43, No. 5.
5. Неразрушающий контроль: справочник в 7 т.; под общ. ред. В.В. Ключева. – Т. 2. – М.: Машиностроение, 2003. – 688 с.
6. Büyüköztürk Oral. Nondestructive Testing of Materials and Structures / Oral Büyüköztürk, Mehmet Ali Taşdemir. – RILEM Bookseries. – 2012. – Vol. 6. – 1278 p. <https://doi.org/10.1007/978-94-007-0723-8>.
7. Горкунов Б.М. Вихрековый двухпараметровый контроль ферромагнитных цилиндрических изделий / Б.М. Горкунов, И.В. Тюпа // *Вестник НТУ "ХПИ"*. – 2004. – № 5. – С. 93-99.
8. Горкунов Б.М. Многопараметровый электромагнитный контроль токопроводов в пространственнопериодических полях / Б.М. Горкунов, А.А. Тищенко, И.Б. Горкунова // *Актуальні проблеми автоматики і приладобудування*. – Х.: НТУ "ХПИ". – 2014. – С. 39-40.
9. Landau L.D. Electrodynamics of continuous environments / L.D. Landau, E.M. Livshits. – М.: Гос. Издательство физико-математической литературы, 1959. – 532 p.
10. Справочник по специальным функциям с формулами, графиками и математическими таблицами / М. Абрамовиц, М. Стиган. – М.: Наука, 1979. – 832 с.

### References

1. Klyuev, V.V. (1996), "Izmereniya, kontrol, ispytaniya i diagnostika" [*Measurement, control, testing and diagnostics*], Mashinostroenie, Moscow, 464 p.
2. Klyuev, S.V., Shkatov, P.N. and Klyuev, V.V. (2011), "Kombinirovannyye metody vihretkovogo, magnitnogo i elektropotentsialnogo kontrolya" [*Combined methods of eddy-current, magnet, electromagnetic testing*], Spektr, Moscow, 190 p.
3. García-Martín, J., Gómez-Gil, J. and Vázquez-Sánchez, E. (2011), Non-Destructive Techniques Based on Eddy Current Testing, *Sensors*, No. 11, pp. 2525-2565. <https://doi.org/10.3390/s110302525>.
4. Sophian, A., Tian, G.Y., Taylor, D. and Rudlin, J. (2001), Electromagnetic and eddy current NDT: a review, *Insight*, Vol. 43, No. 5.
5. Klyuev, V.V. (2003), "Nerazrushayuschiy kontrol: Spravochnik v 7 T." [*Non-destructive testing. Handbook in 7 Vol.*]: Mashinostroenie, Moscow, 688 p.
6. Büyüköztürk, Oral, Taşdemir, Mehmet Ali (2012), Nondestructive Testing of Materials and Structures, *RILEM Bookseries*, Vol. 6, 1278 p. <https://doi.org/10.1007/978-94-007-0723-8>.
7. Gorkunov, B.M. and Tyupa, I.V. (2004), "Vihretkovyyiy dvuhparametrovyyiy kontrol ferromagnitnykh tsilindricheskikh izdeliy" [*Eddy-current two-parameter testing of ferromagnetic cylindrical bodies*], *Vesnik NTU "KhPI"*, No. 5, pp. 93-99.

8. Gorkunov, B.M., Tischenko, A.A. and Gorkunova, I.B. (2014), “Mnogoparmetrovyiy elektromagnitnyiy kontrol tokoprovodov v prostranstvennoperiodicheskikh polyah” [Multi-parameter electromagnetic testing of current conductors in spatially-periodical fields], *Aktualni problemi avtomatiki i priladobuduvannya*, NTU “KhPI”, pp. 39-40.

9. Landau, L.D. and Livshits, E.M. (1959), *Electrodynamics of continuous environments*, Gos. izdatelstvo fiziko-matematicheskoy literatury, Moscow, 532 p.

10. Abramovits, M. and Stigan, M. (1979), “*Spravochnik po spetsialnyim funktsiyam s formulami, grafikami i matematicheskimi tablitsami*” [Handbook for special functions with formulas, graphs and math tables], Nauka, Moscow, 832 p.

Received by Editorial Board 12.09.2018

Signed for Printing 11.12.2018

**Відомості про авторів:**

**Горкунов Борис Митрофанович**

доктор технічних наук професор  
Національного технічного університету  
“Харківський політехнічний інститут”,  
Харків, Україна  
<https://orcid.org/0000-0002-8175-858X>

**Львов Сергій Геннадійович**

кандидат технічних наук доцент  
Національного технічного університету  
“Харківський політехнічний інститут”,  
Харків, Україна  
<https://orcid.org/0000-0003-3830-0570>

**Борисенко Євген Анатолійович**

кандидат технічних наук  
Національного технічного університету  
“Харківський політехнічний інститут”,  
Харків, Україна  
<https://orcid.org/0000-0001-7511-2590>

**Information about authors:**

**Borys Gorkunov**

Doctor of Technical Sciences Professor  
of National Technical University  
of “Kharkiv Polytechnic Institute”,  
Kharkiv, Ukraine  
<https://orcid.org/0000-0002-8175-858X>

**Sergii Lvov**

Candidate of Technical Sciences Associate Professor  
of National Technical University  
of “Kharkiv Polytechnic Institute”,  
Kharkiv, Ukraine  
<https://orcid.org/0000-0003-3830-0570>

**Yevhen Borysenko**

Candidate of Technical Sciences  
of National Technical University  
of “Kharkiv Polytechnic Institute”,  
Kharkiv, Ukraine  
<https://orcid.org/0000-0001-7511-2590>

**ОЦІНКА НЕВИЗНАЧЕНОСТІ ПРИ БАГАТОПАРАМЕТРОВОМУ ВИХРОСТРУМОВОМУ КОНТРОЛІ**

Б.М. Горкунов, С.Г. Львов, Є.А. Борисенко

*Стаття присвячена проблемі неруйнівного контролю металевих виробів та показує перевагу багатопараметрового вихрострумowego методу, який дозволяє визначити провідність та магнітну проникність випробуваного об'єкта на додаток до виявлення дефектів. Наведено опис конструкції та способу підключення вихрострумowego перетворювача із використанням просторово-періодичного розкладання електромагнітного поля. Описаний математичний апарат, який дозволяє вирішувати зворотну задачу, а саме визначити параметри випробуваного об'єкта. Наведено та обґрунтовано доцільність використання графічно-аналітичного методу оцінки стандартної невизначеності параметрів контрольованого об'єкта.*

**Ключові слова:** *неруйнівний багатопараметровий вихрострумовой контроль, просторово-періодична структура електромагнітного поля.*

**ОЦЕНКА НЕОПРЕДЕЛЕННОСТИ ПРИ МНОГОПАРАМЕТРОВОМ ВИХРЕТОКОВОМ КОНТРОЛЕ**

Б.М. Горкунов, С.Г. Львов, Е.А. Борисенко

*В статье рассмотрена задача неразрушающего контроля металлических изделий с целью определения их электромагнитных характеристик либо идентификации принадлежности к определенной марке сплава. Показано преимущество многопараметрового вихретокового метода, который кроме обнаружения дефектов позволяет решить обратную задачу неразрушающего контроля, которая заключается в определении электропроводности, магнитной проницаемости и геометрического параметра контролируемого изделия путем обработки измерительных сигналов, обусловленных реакцией электромагнитного поля на внесение в него исследуемого объекта. Также в статье использован подход, позволяющий представить структуру поля внутри, вблизи поверхности и за пределами исследуемого объекта в виде ряда пространственных гармоник для радиальной и тангенциальной составляющих напряженности. Приведена конструкция и описан алгоритм работы вихретокового преобразователя, использующего пространственно-периодическое представление электромагнитного поля. Описан алгоритм, позволяющий совместно определить магнитную проницаемость, удельную проводимость и диаметр цилиндрического металлического объекта при обработке сигнала первых двух пространственных гармоник поля. Показано, что в виду использования громоздкого математического аппарата представляется затруднительным расчет стандартной неопределенности по классическому подходу. Приведен графо-аналитический метод оценивания стандартной неопределенности на примере измерения магнитной проницаемости. Произведено сравнение двух методов с применением аппроксимации значений магнитной проницаемости на числовой оси, построенной по графическим данным, полученным с применением описанного в статье математического аппарата. Анализ полученных значений показал, что предлагаемый метод дает значения неопределенности с достаточной точностью характеризующие область размытия значений измеряемого параметра.*

**Ключевые слова:** *неразрушающий многопараметровый вихретоковый контроль, пространственно-периодическая структура электромагнитного поля.*