



UDC 539.3

TRANSMISSION OF TORQUE FROM THE SYSTEM OF A HARD STAMPS TO THE CONTOUR OF A CIRCULAR HOLE IN AN INFINITE PLATE

Volodymyr Siaskyi

Rivne State University of Humanities, Rivne, Ukraine

Summary. Contact interaction of hard stamps with angular points and massive elastic bodies with circular cylindrical holes is investigated in this article. Refined interaction model considers the initial difference of curvature of contacting surfaces and features the transfer of torque from stamps to an elastic body by friction forces, which are set by Kulon's law. Based on the expressions for displacement of contour points of elastic body, the system of singular integral equations with logarithmic kernels was created. Solution of the equation system allows to determine the position and size of the contact zone, stress-strain state on the border of elastic body and value of clamping force in the system of stamps, which ensures the maximum torque transmission and ensures minimum crushing of material. Depending on the ratio between the curvature surfaces of contacting bodies, different options of interaction are analyzed.

Key words: hard stamp with angular points, friction, torque, contact stresses, singular integral equations with logarithmic kernels.

Received 27.10.2016

Introduction and problem setting. Calculating friction gears, brake systems for transport and lifting equipment, developing devices for fixing work pieces and cutting tools in manufacturing machine tools and fixing geophysical instruments and equipment in wells are widely used solutions of the pressure of a hard stamps with angular points on the circular surface a cylindrical hole in the massive body or on the lateral surface of the circular disk or shaft. The contact between the body and stamp is provided by the system of the balanced forces applied along the axes of the symmetry stamps, and the moment of the forces couple evenly distributed along all stamps. The torque transfer from the system stamps to the body is performed by the friction forces in the contact zone. It is crucial to research dependence of the stress-strain state of the elastic body on the geometrical parameters of friction in the contact zone. Determining of the distribution of contact stresses is vital to solve problems of the co-tangent bodies strength, their durability, thermal calculation of the rubbing surfaces and etc.

Analysis of recent research and publications. Smooth stamps indentation without angular points on the cylindrical surface of the elastic bodies when contacting curvature contours are close and with a solid contact zone are investigated in [1, 2]. The interaction of two rigid stamps with corner points of the elastic round disk or elastic plate with a circular cylindrical hole with equal contacting surfaces curvature radius are considered in [3]. Further research in this area involved the use of any number of identical symmetrical stamps with corner points [4]. These are the idealized objectives. In most technical applications there is stamps pressure on the bodies' surface with curvature radii which exceed any elastic deformation. In this case it is possible to consider the contacting surfaces as the ones devoid of roughness, and their curvatures are constant. An example of such technical problem is fixing of cutting tools (drills, mills) or blanks in the clamping chucks of the processing machines. A chuck with one set of clamping stamps is used for fixing tools or work pieces of different diameters. In this case it is crucial to establish the magnitude of clamping force in the chucks, which ensures maximum torque transmission and ensures minimum material crushing.

The purpose of the study is to build an improved model of the torque transfer system of hard stamps with angular points to a massive isotropic body with a circular cylindrical hole by frictional forces in general, when the radii of the curvature of the contacting surfaces differ by finite value.

Setting objectives. This is the case of massive elastic body, which is considered as an infinite isotropic plate with thickness of $2h$. In a circular cylindrical hole of the plate with radius $R=1$ evenly distributed N identical symmetric hard stamps with angular points supported by system of parallel rails (Figure 1). The shape and size of the stamps are characterized by the radius r of the contacting surface and the distance between the corner points $2d$. Generating surfaces of the interacting bodies are parallel, and the radii of curvature differ in a finite value that is of the order of elastic displacement. The contact between the plate and stamps is supported by the equilibrium forces P_0 acting along the axes of symmetry stamps. Progressive radial displacement of stamps is provided by a pair of parallel rails. There is no friction between the parallel rails and stamps side surfaces. All rails form a single rigid system, in the center of which some forces with moment M_0 are applied. The torque to the plate is transmitted through the stamps due to friction forces.

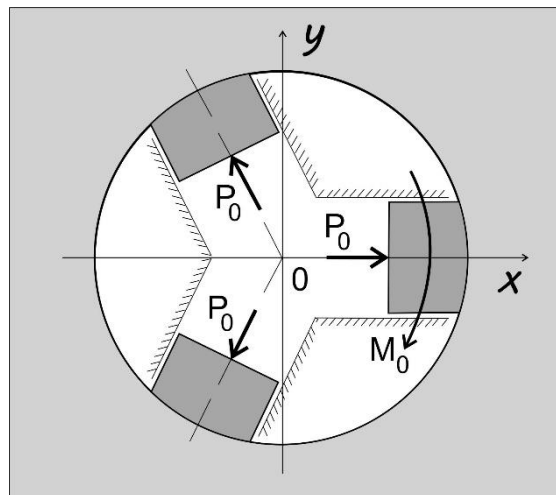

Figure 1. Scheme of the stamps and plate interaction

Since the radii of the stamps surfaces and the hole are different, the sizes of pre-contact sites are unknown and should be defined. The interaction of stamps and plates in the contact are normal T_ρ and tangential forces $S_{\rho\lambda}$ must be determined. The ring tension T_λ on the contour of the hole γ should be determined as well. Of special interest is the limit value of moment M_0 that can be transmitted to the plate without sliding at a given force P_0 and value of the forward stamps displacement.

It is believed that the system of the stamps plate is under generalized plane stress. This section examines the middle of interacting bodies. Depending on the ratio between the contacting surfaces radii there are two possibilities of plate and stamps interaction. The first option is when the radius of the stamps surfaces curvature is smaller than the radius of the elastic body surface curvature. In this case there is one contact area with the unknown boundaries in the vicinity of the stamp middle point. The second option is when the radius of curvature of the stamps surfaces is bigger than the radius of the curvature surface of the elastic body. In this case there will be two areas of contact with unknown internal limits that will apply from external corner points towards each other. Since the interaction of bodies is a torque

transmission by frictional forces, in both cases the contact areas are asymmetric in relation to the stamps symmetry axes.

Defining the system of equations of the mathematical model of the problem.

Firstly, we consider the case $r < R$. If the force P_0 does not provide full surfaces contact, we can talk about the contact problem for the stamps without corner points [1, 2].

The system of the rectangular and polar coordinates is entered so that its beginning O_1 coincides with the hole center in the plate, and the axis Ox coincides with the symmetry axis of the one of the stamps (Figure 2). Unsymmetrical contact zone of the single stamp is characterized by arc coordinates β_1, β_2 . The full contact zone follows

$$L \equiv [\beta_1; \beta_2] \cup \left[\frac{2\pi}{N} + \beta_1; \frac{2\pi}{N} + \beta_2 \right] \cup \dots \cup \left[\frac{2\pi(N-1)}{N} + \beta_1; \frac{2\pi(N-1)}{N} + \beta_2 \right].$$

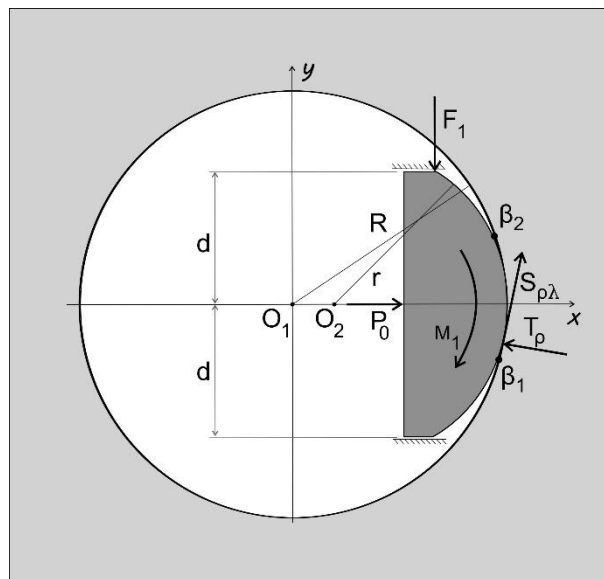

Figure 2. Calculation model for a single stamp

The torque transfer from the guides system to the stamp is performed by the reaction force F_1 at the point of the one of the guides which is in contact with the angular stamp point after its shift as a hard whole and the moment M_1 of a couple of forces. The force F_1 and the moment M_1 are unknown and to be defined.

The terms of the contact of the interacting bodies are elected as equity of the normal displacement of common points of the contacting surfaces. It is assumed that the contour plate points that are not in contact with stamps remain motionless. Due to the contact area geometry, and the friction forces according to Coulomb's law, boundary conditions of the problem can be defined as [3]

$$u(\lambda) + tg\lambda \cdot v(\lambda) = U_0 + \sqrt{r^2 - R^2 \sin^2 \lambda} - R \cos \lambda + R - r, \quad \lambda \in L; \tag{1}$$

$$S_{\rho\lambda}(\lambda) = f \cdot T_{\rho}(\lambda), \quad \lambda \in L. \tag{2}$$

Here $u(\lambda), v(\lambda)$ – the projection of the displacement vector of the contour points on the axes coordinate; f – Coefficient of sliding friction; U_0 – dimension of the stamp displacement as a hard whole.

The components of the vector displacement of plate contour points for a given load are determined by the formulas [3]

$$\begin{aligned} u(\lambda) &= \frac{1}{2Eh} \left[(1-\nu)f_1(\lambda) + \frac{1}{\pi} \int_{\beta_1}^{\lambda} f_2(t) \operatorname{ctg} \frac{\lambda-t}{2} dt + C_1 \right]; \\ v(\lambda) &= \frac{1}{2Eh} \left[(1-\nu)f_2(\lambda) - \frac{1}{\pi} \int_{\beta_1}^{\lambda} f_1(t) \operatorname{ctg} \frac{\lambda-t}{2} dt + C_2 \right], \end{aligned} \quad (3)$$

where $f_1(\lambda) + if_2(\lambda) = i \int_{\beta_1}^{\lambda} (T_{\rho}(t) + iS_{\rho\lambda}(t)) e^{it} dt$; E , ν – Young's modulus and Poisson's ratio of the plate material; C_1 , C_2 are steel actuals.

Considering functions properties $f_1(\lambda)$ and $f_2(\lambda)$ and terms of the problem frequency [4], equation (3) can be written as

$$\begin{aligned} u(\lambda) &= \frac{1}{2Eh} \cdot \left[(1-\nu) \int_{\beta_1}^{\lambda} f_1'(t) dt + \frac{2}{\pi} \int_{\beta_1}^{\beta_2} f_2'(t) \ln \left| \sin \frac{\lambda-t}{2} \right| dt + \right. \\ &\quad \left. + \frac{2}{\pi} \sum_{k=1}^{N-1} \int_{\beta_1}^{\beta_2} \left(f_1'(t) \sin \frac{2\pi k}{N} + f_2'(t) \cos \frac{2\pi k}{N} \right) \ln \left| \sin \left(\frac{\lambda-t}{2} - \frac{k\pi}{N} \right) \right| dt + C_1 \right]; \\ v(\lambda) &= \frac{1}{2Eh} \cdot \left[(1-\nu) \int_{\beta_1}^{\lambda} f_2'(t) dt - \frac{2}{\pi} \int_{\beta_1}^{\beta_2} f_1'(t) \ln \left| \sin \frac{\lambda-t}{2} \right| dt + \right. \\ &\quad \left. + \frac{2}{\pi} \sum_{k=1}^{N-1} \int_{\beta_1}^{\beta_2} \left(f_2'(t) \sin \frac{2\pi k}{N} - f_1'(t) \cos \frac{2\pi k}{N} \right) \ln \left| \sin \left(\frac{\lambda-t}{2} - \frac{k\pi}{N} \right) \right| dt + C_2 \right], \end{aligned} \quad (4)$$

where $C_1 = -\frac{(1-\nu)}{2} \cdot \left(f_1(\beta_2) - f_2(\beta_2) \operatorname{ctg} \frac{\pi}{N} \right)$; $C_2 = -\frac{(1-\nu)}{2} \cdot \left(f_2(\beta_2) + f_1(\beta_2) \operatorname{ctg} \frac{\pi}{N} \right)$.

Substitution (4) into the boundary conditions (1), (2) results in a system of two singular integral equations with logarithmic kernels to determine the functions $f_1'(\lambda)$ and $f_2'(\lambda)$. In this system limit equilibrium conditions of each stamp must be followed

$$f_2(\beta_2) = -P_0; \quad f_1(\beta_2) = -F_1; \quad \frac{F_1 \sqrt{r^2 - d^2} + M_1}{r} = \int_{\beta_1}^{\beta_2} S_{\rho\lambda}(t) dt = -\frac{M_0}{NR}, \quad (5)$$

which are used to determine the unknown quantities U_0 , F_1 , M_1 .

The construction of the resulting system of integral equations to the standard period of integration $[-1;1]$ is done by substitution of variables

$$\operatorname{tg} \frac{\lambda}{2} = \frac{b_2 - b_1}{2} x + \frac{b_2 + b_1}{2}; \quad \operatorname{tg} \frac{t}{2} = \frac{b_2 - b_1}{2} s + \frac{b_2 + b_1}{2};$$

$$b_1 = tg\left(\frac{\beta_1}{2}\right); \quad b_2 = tg\left(\frac{\beta_2}{2}\right), \quad \lambda, t \in [\beta_1; \beta_2], \quad x, s \in [-1; 1], \quad (6)$$

which leads to new unknown functions $\Phi_1(x)$ and $\Phi_2(x)$ and related to functions $f'_1(\lambda)$ and $f'_2(\lambda)$ relationships

$$\Phi_j(x) = f'_j(\lambda) \frac{4(b_2 - b_1)}{4 + ((b_2 - b_1)x + b_2 + b_1)^2}, \quad (j = 1, 2). \quad (7)$$

As a result, a system of singular integral equations with logarithmic kernels to determine the functions $\Phi_1(x)$ and $\Phi_2(x)$ has been constructed

$$\begin{aligned} & (1 - \nu) \int_{-1}^x \Phi_1(s) ds + \frac{2}{\pi} \int_{-1}^1 \Phi_2(s) \ln \left| (x-s) \frac{(b_2 - b_1)}{2} \cos \frac{\lambda}{2} \cos \frac{t}{2} \right| ds + \\ & + \frac{2}{\pi} \sum_{k=1}^{N-1} \int_{-1}^1 \left(\Phi_1(s) \sin \frac{2\pi k}{N} + \Phi_2(s) \cos \frac{2\pi k}{N} \right) \ln \left| \sin \left(\frac{\lambda - t}{2} - \frac{k\pi}{N} \right) \right| ds + \\ & + tg\lambda \cdot \left[(1 - \nu) \int_{-1}^x \Phi_2(s) ds - \frac{2}{\pi} \int_{-1}^1 \Phi_1(s) \ln \left| (x-s) \frac{(b_2 - b_1)}{2} \cos \frac{\lambda}{2} \cos \frac{t}{2} \right| ds + \right. \\ & \left. + \frac{2}{\pi} \sum_{k=1}^{N-1} \int_{-1}^1 \left(\Phi_2(s) \sin \frac{2\pi k}{N} - \Phi_1(s) \cos \frac{2\pi k}{N} \right) \ln \left| \sin \left(\frac{\lambda - t}{2} - \frac{k\pi}{N} \right) \right| ds \right] = \\ & = 2Eh \left(U_0 + \sqrt{r^2 - R^2 \sin^2 \lambda} - R \cos \lambda + R - r \right) - C_1 - C_2 \cdot tg\lambda; \end{aligned} \quad (8)$$

$$(1 - f \cdot tg\lambda)\Phi_1(x) + (tg\lambda + f)\Phi_2(x) = 0, \quad \lambda \in [\beta_1; \beta_2], \quad x \in [-1; 1]; \quad (9)$$

$$\int_{-1}^1 \Phi_2(s) ds = -P_0; \quad \int_{-1}^1 \Phi_1(s) ds = -F_1; \quad \frac{F_1 \sqrt{r^2 - d^2} + M_1}{r} = \int_{\beta_1}^{\beta_2} S_{\rho\lambda}(t) dt = -\frac{M_0}{NR}, \quad (10)$$

where
$$C_1 = \frac{(1 - \nu)}{2} \cdot \left(F_1 - P_0 ctg \frac{\pi}{N} \right); \quad C_2 = \frac{(1 - \nu)}{2} \cdot \left(P_0 + F_1 ctg \frac{\pi}{N} \right).$$

If the solution of the problem (8), (9), (10) becomes known, the components of the stress state on a path are determined by formulas [4]

$$T_\rho(\lambda) = \Phi_2(x) \cdot \frac{4 - ((b_2 - b_1)x + b_2 + b_1)^2}{4(b_2 - b_1)} - \Phi_1(x) \cdot \frac{(b_2 - b_1)x + b_2 + b_1}{b_2 - b_1};$$

$$S_{\rho\lambda}(\lambda) = f \cdot T_\rho(\lambda), \quad \lambda \in [\beta_1; \beta_2], \quad x \in [-1; 1];$$

$$T_\lambda(\lambda) = T_\rho(\lambda) - \frac{N}{\pi} \int_{\beta_1}^{\beta_2} T_\rho(t) dt + \frac{N \cdot f}{\pi} \int_{\beta_1}^{\beta_2} T_\rho(t) ctg \left(\frac{N(\lambda - t)}{2} \right) dt, \quad \lambda \in [0; 2\pi]. \quad (11)$$

Now we will consider the case $r > R$. If the force P_0 provides full contact of the surfaces, then we can talk about the contact problem for symmetric single tied stamps with

corner points [3, 4].

The system of the rectangular and polar coordinates is introduced as in the previous case (Figure 3). Internal limits of the asymmetrical contact zones are characterized arc coordinates β_1, β_2 . Then the complete contact zone can be defined as the following

$$L \equiv [-\alpha_0; \beta_1] \cup [\beta_2; \alpha_0] \cup \left[\frac{2\pi}{N} - \alpha_0; \frac{2\pi}{N} + \beta_1 \right] \cup \left[\frac{2\pi}{N} + \beta_2; \frac{2\pi}{N} + \alpha_0 \right] \cup \dots \cup \left[\frac{2\pi(N-1)}{N} - \alpha_0; \frac{2\pi(N-1)}{N} + \beta_1 \right] \cup \left[\frac{2\pi(N-1)}{N} + \beta_2; \frac{2\pi(N-1)}{N} + \alpha_0 \right].$$

Here $\alpha_0 = \arcsin(d/R)$ is the dimension of the polar angle point of the plate, which coincides with the corner point of the stamp.

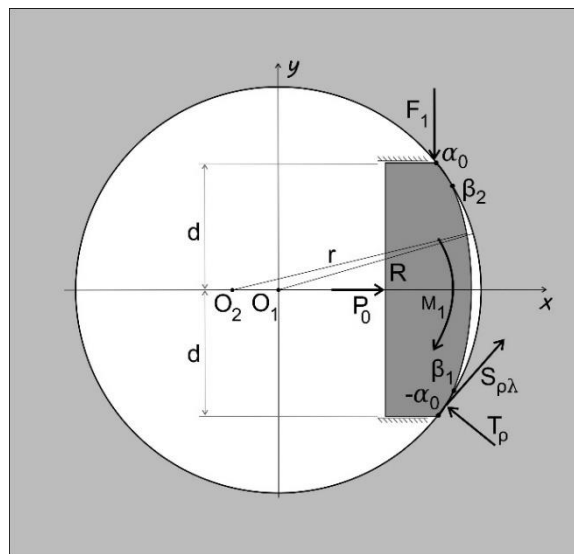

Figure 3. Calculation model for a single stamp

Transfer of the torque from the system is performed by the power of reaction F_1 in the extreme point of one of the guides corresponding to the outer limits of the contact α_0 , and moment M_1 of a force couple.

As in the previous case, the conditions of contact interacting bodies are elected as equity normal displacement of the common points of the contacting surfaces. Because of the assumption of real points γ of the circuit, which is not in contact with stamps, boundary condition (1) will look like

$$u(\lambda) + tg\lambda \cdot v(\lambda) = U_0 + \sqrt{r^2 - R^2 \sin^2 \lambda} - R \cos \lambda + R \cos \alpha_0 - \sqrt{r^2 - d^2}, \quad \lambda \in L. \quad (12)$$

Taking into account the nature of the contact the expressions for the components of the vector displacement of the plate contour points will have the same structure as the ratio (4). Substituting them into boundary conditions (12) considering (2) leads to a system of two singular integral equations with logarithmic kernels to determine the functions $f_1'(\lambda)$ and $f_2'(\lambda)$. Except for the system, limit equilibrium conditions of each stamp must be the following

$$f_2(\alpha_0) = \int_{-\alpha_0}^{\beta_1} f_2'(t)dt + \int_{\beta_2}^{\alpha_0} f_2'(t)dt = -P_0; \quad f_1(\alpha_0) = \int_{-\alpha_0}^{\beta_1} f_1'(t)dt + \int_{\beta_2}^{\alpha_0} f_1'(t)dt = -F_1;$$

$$\frac{F_1\sqrt{r^2 - d^2} + M_1}{r} = \int_{-\alpha_0}^{\beta_1} S_{\rho\lambda}(t)dt + \int_{\beta_2}^{\alpha_0} S_{\rho\lambda}(t)dt = -\frac{M_0}{NR}, \quad (13)$$

which are used to determine the unknown quantities U_0, F_1, M_1 .

The construction of the resulting system of integral equations to the standard period of integration $[-1;1]$ is realized through the substitution of variables

$$\begin{aligned} \operatorname{tg} \frac{\lambda}{2} &= \frac{b_1+a_0}{2} x + \frac{b_1-a_0}{2}; & \operatorname{tg} \frac{t}{2} &= \frac{b_1+a_0}{2} s + \frac{b_1-a_0}{2}; \\ \operatorname{tg} \frac{\tilde{\lambda}}{2} &= \frac{a_0-b_2}{2} \tilde{x} + \frac{a_0+b_2}{2}; & \operatorname{tg} \frac{\tilde{t}}{2} &= \frac{a_0-b_2}{2} \tilde{s} + \frac{a_0+b_2}{2}; \\ a_0 &= \operatorname{tg} \left(\frac{\alpha_0}{2} \right); & b_1 &= \operatorname{tg} \left(\frac{\beta_1}{2} \right); & b_2 &= \operatorname{tg} \left(\frac{\beta_2}{2} \right); \\ \lambda, t &\in [-\alpha_0; \beta_1]; & \tilde{\lambda}, \tilde{t} &\in [\beta_2; \alpha_0]; & x, s, \tilde{x}, \tilde{s} &\in [-1;1], \end{aligned} \quad (14)$$

which leads to new unknown functions $\Phi_1(x), \Phi_2(x), \tilde{\Phi}_1(\tilde{x}), \tilde{\Phi}_2(\tilde{x})$. These functions are defined in different parts of the contact area and relate to $f_1'(\lambda)$ and $f_2'(\lambda)$ by the relationships and

$$\begin{aligned} \Phi_j(x) &= f_j'(\lambda) \frac{4(b_1+a_0)}{4 + ((b_1+a_0)x + b_1 - a_0)^2}, \quad (j=1,2), \quad \lambda \in [-\alpha_0; \beta_1], \quad x \in [-1;1]; \\ \tilde{\Phi}_j(\tilde{x}) &= f_j'(\tilde{\lambda}) \frac{4(a_0-b_2)}{4 + ((a_0-b_2)\tilde{x} + a_0 + b_2)^2}, \quad (j=1,2), \quad \tilde{\lambda} \in [\beta_2; \alpha_0], \quad \tilde{x} \in [-1;1]. \end{aligned} \quad (15)$$

As a result, a system of singular integral equations with logarithmic kernels has been created to determine functions $\Phi_1(x), \Phi_2(x), \tilde{\Phi}_1(\tilde{x}), \tilde{\Phi}_2(\tilde{x})$

$$\begin{aligned} &(1-\nu) \int_{-1}^x \Phi_1(s)ds + \frac{2}{\pi} \int_{-1}^1 \Phi_2(s) \ln \left| (x-s) \frac{(b_1+a_0)}{2} \cos \frac{\lambda}{2} \cos \frac{t}{2} \right| ds + \\ &+ \frac{2}{\pi} \int_{-1}^1 \tilde{\Phi}_2(\tilde{s}) \ln \left| \left(\frac{b_1+a_0}{2} x + \frac{b_1-a_0}{2} - \frac{a_0-b_2}{2} \tilde{s} - \frac{a_0+b_2}{2} \right) \cos \frac{\lambda}{2} \cos \frac{\tilde{t}}{2} \right| d\tilde{s} + \\ &+ \frac{2}{\pi} \sum_{k=1}^{N-1} \int_{-1}^1 \left(\Phi_1(s) \sin \frac{2\pi k}{N} + \Phi_2(s) \cos \frac{2\pi k}{N} \right) \ln \left| \sin \left(\frac{\lambda-t}{2} - \frac{k\pi}{N} \right) \right| ds + \\ &+ \frac{2}{\pi} \sum_{k=1}^{N-1} \int_{-1}^1 \left(\tilde{\Phi}_1(\tilde{s}) \sin \frac{2\pi k}{N} + \tilde{\Phi}_2(\tilde{s}) \cos \frac{2\pi k}{N} \right) \ln \left| \sin \left(\frac{\lambda-\tilde{t}}{2} - \frac{k\pi}{N} \right) \right| d\tilde{s} + \end{aligned}$$

$$\begin{aligned}
 & + tg\lambda \cdot \left[(1-\nu) \int_{-1}^x \Phi_2(s) ds - \frac{2}{\pi} \int_{-1}^1 \Phi_1(s) \ln \left| (x-s) \frac{(b_2-b_1)}{2} \cos \frac{\lambda}{2} \cos \frac{t}{2} \right| ds - \right. \\
 & - \frac{2}{\pi} \int_{-1}^1 \tilde{\Phi}_1(\tilde{s}) \ln \left| \left(\frac{b_1+a_0}{2} x + \frac{b_1-a_0}{2} - \frac{a_0-b_2}{2} \tilde{s} - \frac{a_0+b_2}{2} \right) \cos \frac{\lambda}{2} \cos \frac{\tilde{t}}{2} \right| d\tilde{s} + \\
 & + \frac{2}{\pi} \sum_{k=1}^{N-1} \int_{-1}^1 \left(\Phi_2(s) \sin \frac{2\pi k}{N} - \Phi_1(s) \cos \frac{2\pi k}{N} \right) \ln \left| \sin \left(\frac{\lambda-t}{2} - \frac{k\pi}{N} \right) \right| ds + \\
 & + \frac{2}{\pi} \sum_{k=1}^{N-1} \int_{-1}^1 \left(\tilde{\Phi}_2(\tilde{s}) \sin \frac{2\pi k}{N} - \tilde{\Phi}_1(\tilde{s}) \cos \frac{2\pi k}{N} \right) \ln \left| \sin \left(\frac{\lambda-\tilde{t}}{2} - \frac{k\pi}{N} \right) \right| d\tilde{s} \Big] = \\
 & = 2Eh \left(U_0 + \sqrt{r^2 - R^2 \sin^2 \lambda} - R \cos \lambda + R \cos \alpha_0 - \sqrt{r^2 - d^2} \right) - C_1 - C_2 \cdot tg\lambda ;
 \end{aligned} \tag{16}$$

$$(1-f \cdot tg\lambda) \Phi_1(x) + (tg\lambda + f) \Phi_2(x) = 0, \quad \lambda \in [-\alpha_0; \beta_1], \quad x \in [-1; 1]; \tag{17}$$

$$\begin{aligned}
 & (1-\nu) \left(\int_{-1}^1 \Phi_1(s) ds + \int_{-1}^{\tilde{x}} \tilde{\Phi}_1(\tilde{s}) d\tilde{s} \right) + \frac{2}{\pi} \int_{-1}^1 \tilde{\Phi}_2(\tilde{s}) \ln \left| (\tilde{x}-\tilde{s}) \frac{(a_0-b_2)}{2} \cos \frac{\tilde{\lambda}}{2} \cos \frac{\tilde{t}}{2} \right| d\tilde{s} + \\
 & + \frac{2}{\pi} \int_{-1}^1 \Phi_2(s) \ln \left| \left(\frac{a_0-b_2}{2} \tilde{x} + \frac{a_0+b_2}{2} - \frac{b_1+a_0}{2} s - \frac{b_1-a_0}{2} \right) \cos \frac{\tilde{\lambda}}{2} \cos \frac{t}{2} \right| ds + \\
 & + \frac{2}{\pi} \sum_{k=1}^{N-1} \int_{-1}^1 \left(\Phi_1(s) \sin \frac{2\pi k}{N} + \Phi_2(s) \cos \frac{2\pi k}{N} \right) \ln \left| \sin \left(\frac{\tilde{\lambda}-t}{2} - \frac{k\pi}{N} \right) \right| ds + \\
 & + \frac{2}{\pi} \sum_{k=1}^{N-1} \int_{-1}^1 \left(\tilde{\Phi}_1(\tilde{s}) \sin \frac{2\pi k}{N} + \tilde{\Phi}_2(\tilde{s}) \cos \frac{2\pi k}{N} \right) \ln \left| \sin \left(\frac{\tilde{\lambda}-\tilde{t}}{2} - \frac{k\pi}{N} \right) \right| d\tilde{s} + \\
 & + \left[(1-\nu) \left(\int_{-1}^1 \Phi_2(s) ds + \int_{-1}^{\tilde{x}} \tilde{\Phi}_2(\tilde{s}) d\tilde{s} \right) - \frac{2}{\pi} \int_{-1}^1 \tilde{\Phi}_1(\tilde{s}) \ln \left| (\tilde{x}-\tilde{s}) \frac{(a_0-b_2)}{2} \cos \frac{\tilde{\lambda}}{2} \cos \frac{\tilde{t}}{2} \right| d\tilde{s} - \right. \\
 & - \frac{2}{\pi} \int_{-1}^1 \Phi_1(s) \ln \left| \left(\frac{a_0-b_2}{2} \tilde{x} + \frac{a_0+b_2}{2} - \frac{b_1+a_0}{2} s - \frac{b_1-a_0}{2} \right) \cos \frac{\tilde{\lambda}}{2} \cos \frac{t}{2} \right| ds + \\
 & + \frac{2}{\pi} \sum_{k=1}^{N-1} \int_{-1}^1 \left(\Phi_2(s) \sin \frac{2\pi k}{N} - \Phi_1(s) \cos \frac{2\pi k}{N} \right) \ln \left| \sin \left(\frac{\tilde{\lambda}-t}{2} - \frac{k\pi}{N} \right) \right| ds + \\
 & + \frac{2}{\pi} \sum_{k=1}^{N-1} \int_{-1}^1 \left(\tilde{\Phi}_2(\tilde{s}) \sin \frac{2\pi k}{N} - \tilde{\Phi}_1(\tilde{s}) \cos \frac{2\pi k}{N} \right) \ln \left| \sin \left(\frac{\tilde{\lambda}-\tilde{t}}{2} - \frac{k\pi}{N} \right) \right| d\tilde{s} \Big] \cdot tg\tilde{\lambda} = \\
 & = 2Eh \left(U_0 + \sqrt{r^2 - R^2 \sin^2 \tilde{\lambda}} - R \cos \tilde{\lambda} + R \cos \alpha_0 - \sqrt{r^2 - d^2} \right) - C_1 - C_2 \cdot tg\tilde{\lambda} ;
 \end{aligned} \tag{18}$$

$$(1-f \cdot tg\tilde{\lambda}) \tilde{\Phi}_1(\tilde{x}) + (tg\tilde{\lambda} + f) \tilde{\Phi}_2(\tilde{x}) = 0, \quad \tilde{\lambda} \in [\beta_2; \alpha_0], \quad \tilde{x} \in [-1; 1]; \tag{19}$$

$$\int_{-1}^1 \Phi_2(s) ds + \int_{-1}^1 \tilde{\Phi}_2(\tilde{s}) d\tilde{s} = -P_0; \quad \int_{-1}^1 \Phi_1(s) ds + \int_{-1}^1 \tilde{\Phi}_1(\tilde{s}) d\tilde{s} = -F_1;$$

$$\frac{F_1 \sqrt{r^2 - d^2} + M_1}{r} = \int_{-\alpha_0}^{\beta_1} S_{\rho\lambda}(t) dt + \int_{\beta_2}^{\alpha_0} S_{\rho\lambda}(t) dt = -\frac{M_0}{NR}, \quad (20)$$

where

$$C_1 = \frac{(1-\nu)}{2} \cdot \left(F_1 - P_0 \operatorname{ctg} \frac{\pi}{N} \right), \quad C_2 = \frac{(1-\nu)}{2} \cdot \left(P_0 + F_1 \operatorname{ctg} \frac{\pi}{N} \right).$$

The components of the stress state of the hole contour through functions $\Phi_1(x)$, $\Phi_2(x)$, $\tilde{\Phi}_1(\tilde{x})$, $\tilde{\Phi}_2(\tilde{x})$ are determined by formulas

$$T_\rho(\lambda) = \Phi_2(x) \cdot \frac{4 - ((b_1 + a_0)x + b_1 - a_0)^2}{4(b_1 + a_0)} - \Phi_1(x) \cdot \frac{(b_1 + a_0)x + b_1 - a_0}{b_1 + a_0}, \quad \lambda \in [-\alpha_0; \beta_1];$$

$$T_\rho(\tilde{\lambda}) = \tilde{\Phi}_2(\tilde{x}) \cdot \frac{4 - ((a_0 - b_2)\tilde{x} + a_0 + b_2)^2}{4(a_0 - b_2)} - \tilde{\Phi}_1(\tilde{x}) \cdot \frac{(a_0 - b_2)\tilde{x} + a_0 + b_2}{a_0 - b_2}, \quad \tilde{\lambda} \in [\beta_2; \alpha_0];$$

$$S_{\rho\lambda}(\lambda) = f \cdot T_\rho(\lambda), \quad \lambda \in [-\alpha_0; \beta_1] \cup [\beta_2; \alpha_0];$$

$$T_\lambda(\lambda) = T_\rho(\lambda) - \frac{N}{\pi} \left(\int_{-\alpha_0}^{\beta_1} T_\rho(t) dt + \int_{\beta_2}^{\alpha_0} T_\rho(t) dt \right) + \frac{N \cdot f}{\pi} \left(\int_{-\alpha_0}^{\beta_1} T_\rho(t) \operatorname{ctg} \left(\frac{N(\lambda - t)}{2} \right) dt + \int_{\beta_2}^{\alpha_0} T_\rho(t) \operatorname{ctg} \left(\frac{N(\lambda - t)}{2} \right) dt \right), \quad \lambda \in [0; 2\pi]. \quad (21)$$

Conclusions and recommendations for further research:

- the proposed model allows to solve practical problems for optimizing technical systems, which provide friction torque transfer from the system of hard stamps to elastic bodies of circular cylindrical surfaces;
- to clarify the boundary conditions of contact interacting bodies considers possible differences in curves of contacting surfaces and features of torque transfer;
- the constructed system of singular integral equations with logarithmic kernels can be solved by numerical and analytical methods, including the combined method of mechanical quadrature and collocation boundary;
- the implementation of numerical equations system allows to define: the position and size of the contact areas; components of the stress condition in the contour of the elastic body; limit value of torque transmitted by the friction without slippage for a given value clamping force; the value of the progressive stamps displacement.

References

1. Panasiuk V.V., Teplyi M.Y. Deiaki kontaktni zadachi teorii pruzhnosti. Kyiv, Nauk. dumka Publ., 1975. 195 p. [in Ukrainian].
2. Teplyi M.I. Kontaktnye zadachi dlya oblastej s krugovymi granicami. L'vov, Vishha shkola Publ., 1983. 176 p. [in Russian].
3. Siaskyi V.A. Vplyv tertia na rozpodil napruzen pry kontakti hladkykh tsylindrychnykh til i shtampiv z kutovymy tochkamy. Volynskiy matematychniy visnyk, 1999, no. 6, pp. 127 – 134. [in Ukrainian].
4. Siaskyi V. Modeliuvannya napruzeno-deformovanoho stanu v tsylindrychnykh tilakh, shcho vzaemodiut iz systemoiu zhorstkykh shtampiv pry naiavnosti syl tertia. Materialy 6 Vseukrainskoi naukovo-praktychnoi konferentsii "Informatsiini tekhnolohii v profesiinii diialnosti". Rivne, RDHU, 2012, p. 151 – 154. [in Ukrainian].

Список використаної літератури

1. Панасюк, В.В. Деякі контактні задачі теорії пружності [Текст] / В.В. Панасюк, М.Й. Теплий. – Київ: Наук. думка, 1975. – 195 с.
2. Теплый, М.И. Контактные задачи для областей с круговыми границами [Текст] / М.И. Теплый. – Львов: Выща школа, Изд-во при Львов. ун-те, 1983. – 176 с.
3. Сяський, В.А. Вплив тертя на розподіл напружень при контакті гладких циліндричних тіл і штампів з кутовими точками [Текст] / В.А. Сяський // Волинський математичний вісник. – 1999. – Вип. 6. – С. 127 – 134.
4. Сяський, В. Моделювання напружено-деформованого стану в циліндричних тілах, що взаємодіють із системою жорстких штампів при наявності сил тертя [Текст] / Володимир Сяський // «Інформаційні технології в професійній діяльності»: матеріали VI Всеукраїнської науково-практичної конференції. – Рівне: РВВ РДГУ. – 2012. – С. 151 – 154.

УДК 539.3

ПЕРЕДАЧА ОБЕРТАЛЬНОГО МОМЕНТУ ВІД СИСТЕМИ ЖОРСТКИХ ШТАМПІВ ДО КОНТУРУ КРУГОВОГО ОТВОРУ В НЕСКІНЧЕННІЙ ПЛАСТИНЦІ

Володимир Сяський

Рівненський державний гуманітарний університет, Рівне, Україна

Резюме. Досліджено контактну взаємодію системи жорстких штампів із кутовими точками та масивних пружних тіл із круговими циліндричними отворами. Уточнена модель взаємодії враховує початкову різницю кривин контактуючих поверхонь та особливості передавання обертального моменту від штампів до пружного тіла за рахунок сил тертя, заданих законом Кулона. На основі виразів для зміщення контурних точок пружного тіла побудовано систему сингулярних інтегральних рівнянь з логарифмічними ядрами. Розв'язок системи рівнянь дозволяє встановити положення і розмір зони контакту, напружено-деформований стан на контурі пружного тіла та величину притискового зусилля у системі штампів, яке забезпечує максимальне передавання обертального моменту і гарантує мінімальне змінання матеріалу. Розглянуто різні варіанти контактування тіл залежно від співвідношення між радіусами кривин їх поверхонь.

Ключові слова: жорсткий штамп з кутовими точками, сили тертя, обертальний момент, контактні напруження, сингулярні інтегральні рівняння з логарифмічними ядрами.

Отримано 27.10.2016