



UDC 621.865.8

THE ISSUE OF IMPROVE THE MANUFACTURABILITY OF DEVICES FOR MANIPULATING BY MINIATURE OBJECTS

Oleksii Samoilenko

National Technical University of Ukraine „Igor Sikorsky Kyiv Polytechnic Institute“, Kyiv, Ukraine

Summary. *The article discusses the creation of element base micromanipulators that meet certain requirements, such as manufacturability, handheld control, resistance to the adverse effects of the environment and the possibility of full or partial sterilization and protection from wrong actions of the operator. Proposed construction of micromanipulators using parts of the drive chains, commonly rolled sections, on the basis of compliant kinematical devices using a common rod and sheet materials. These proposals are illustrated by the author's own developments, which are protected by patents.*

Key words: *micromanipulator, manipulation, handheld control, guide mechanism, drive chain, rolling profile, compliant kinematical device, flexure hinge, degree of freedom (DOF), rod material, sheet material.*

Received 06.09.2017

Introduction. In recent years there is the miniaturization of techniques and technologies. Traditionally, it is necessary that in manipulating tiny objects are specific to industries such as precision engineering and instrumentation, electronic industry, scientific research in biology and medicine and so on.

One of the interesting areas of application of these micromanipulators is reproductive technologies of agricultural production. And not only in the context of research, but applied with the purpose the farms with different ownership.

For example, in the industrial beekeeping for breeding can be used instrumental artificial insemination of queens of honey bees. For the last almost 100 years using complex devices based on apparatus V. Vesely (Czech) [1] and [2]. The specified (or similar) apparatus is placed under the binocular stereoscopic microscope with a magnification of 8...16 times. The apparatus can be used to implementing the method [3].

Unquestionable advantage of this apparatus is its simplicity as design and procedures for using. However, work with apparatus requires highly skilled operator, and the positive result (the relative number of received fertile queen bees) is dependent subjectively on the precision movements of the operator. In addition, the apparatus can not provide all movements which are provided with more advanced and promising method [8]. Another defect of the device is its low productivity, through which during the working day you can make no more than 10...15 cycles, It may not be sufficient in conditions of large farms.

Professor Valerii D. Brovarkii (NULES of Ukraine, Kyiv) was proposed the concept of technological line [7] for multiple insemination of queen bees with the using of the set of satellite devices, which are equipped with queen bee holder and 3DOF micromanipulator for injector sting. According to the concept, the technological line is equipped with several dozens of satellite devices that are „traveling“ between technological areas.

Analysis of open source patent and scientific information indicates a very interesting and controversial situation. The majority of developments or patents are related to manipulate of macroobjects or submicro- and nano-objects. But the intermediate range – devices to manipulate tiny objects ($10^{-3} \dots 10^{-5} m$) are presented not enough.

In addition, in some cases, including and that described, strict adherence to circular or

linear trajectory of the working organ (e.g., injector sting) is not critical. It is acceptable approximation of the real to the ideal trajectory with deviations within acceptable limits.

Problem statement. The purpose of research is to review methods of creation elements and units of micromanipulators that correspond to the following requirements:

- sufficient precision to manipulate tiny objects under the naked eye and also in a low magnification in the 8x...20x (max 40x);
- high manufacturability and repair ability;
- possibility of handheld control and/or the possibility of applying in the field without quality electricity or no electricity;
- resistance to negative effect of external factors (vibrations and random shocks during transportation, dust, etc.) and negligence in maintenance (e.g., insufficient lubrication);
- the possibility of sterilization and disinfection of the whole mechanism by thermal and/or chemical treatment when fully immersed in the liquid;
- resistance to common organic solvents;
- protection against deliberately wrong actions of the operator during operation and maintenance;
- market attractiveness.

Main article. This purpose can be achieved in many ways, among which are the following:

- using common and cheap standardized parts, rolled profiles, etc. in the designs of micromechanism;
- replacing from the sliding or roller guides to guide mechanism (exact and/or approximate) with only rotational kinematical pairs;
- using of elastic kinematical devices.

An example of the using of standardized components and guiding mechanisms can be considered 3DOF micromanipulator [4], [5] and [6], which kinematical scheme includes two guide mechanism by using only rotational compounds of the components.

Using in the mechanism of the linear movement only of rotational kinematical pairs can improve the accuracy of working organ manipulation because the accuracy of the kinematical chain, in general, hardly depends on the accuracy of the individual elements of the kinematical pair, as occurs in a linear kinematical pair, and depend upon the needed center distance. Using in the mechanism of working organ inclination the double lever four-hinge mechanism, which levers are of equal length and in the neutral position are directed to the geometrical center of the manipulator, frees the geometric center of the manipulator from the hinges and approximate thereto working organ as far as it is caused by assignment of the manipulator, which also leads to an increase in precision manipulation. This double lever four-hinge mechanism in this case is an approximate radial guiding mechanism. However, at low angles of inclination of the working organ and at a certain ratio of the lengths of the mechanism links, it is possible to achieve a predetermined positioning accuracy of the working organ.

Reduce the cost of production of the manipulator is achieved by simplifying the kinematical scheme of the manipulator and the unification of its parts.

Using the several series-connected hinged parallelogram in the mechanism of the straight motion the working organ provides a plane-parallel motion the working organ. The use of additional elastic element is making an additional force limiting in the mechanism structure. It turns 2DOF (in the case of two parallelograms) mechanism to conventionally 1DOF mechanism while maintaining the parallel movement of the working organ, equivalent to more constructively complicated straight line guide mechanism.

Unification of parts can be achieved, for example, because the links of the tilt mechanism and a linear moving mechanism parallelograms can be formed as identical parts. Depending on the requirements for the accuracy of the manipulator links may be used, for

example, individual plates of available sleeve chains.

The essence of the design is explained by kinematical scheme (Fig. 1, *a*) of manipulator which is shown in the neutral position.

At least two series-connected parallelogram mechanism consisting of the links 6 and 7 as well as connecting rods 8 and 9 are connected to the upper portion of the L-shaped frame 5 by means of hinges. The connecting rod 9 of last parallelogram and the upper part of the L-shaped frames 5 are connected to an elastic element 10 which acts on the tensile force and introduces an additional a limitation in parallelogram mechanism, converting it into 1DOF mechanism. The action of linear displacement drive based on counteracting the force of contraction of the elastic element 10. The linear displacement drive may be performed, for example, as a hand screw mechanism 11 which is equipped with a hand wheel 12 and the heel 13, and creates at least 3DOF planar connection with L-shaped frame 5.

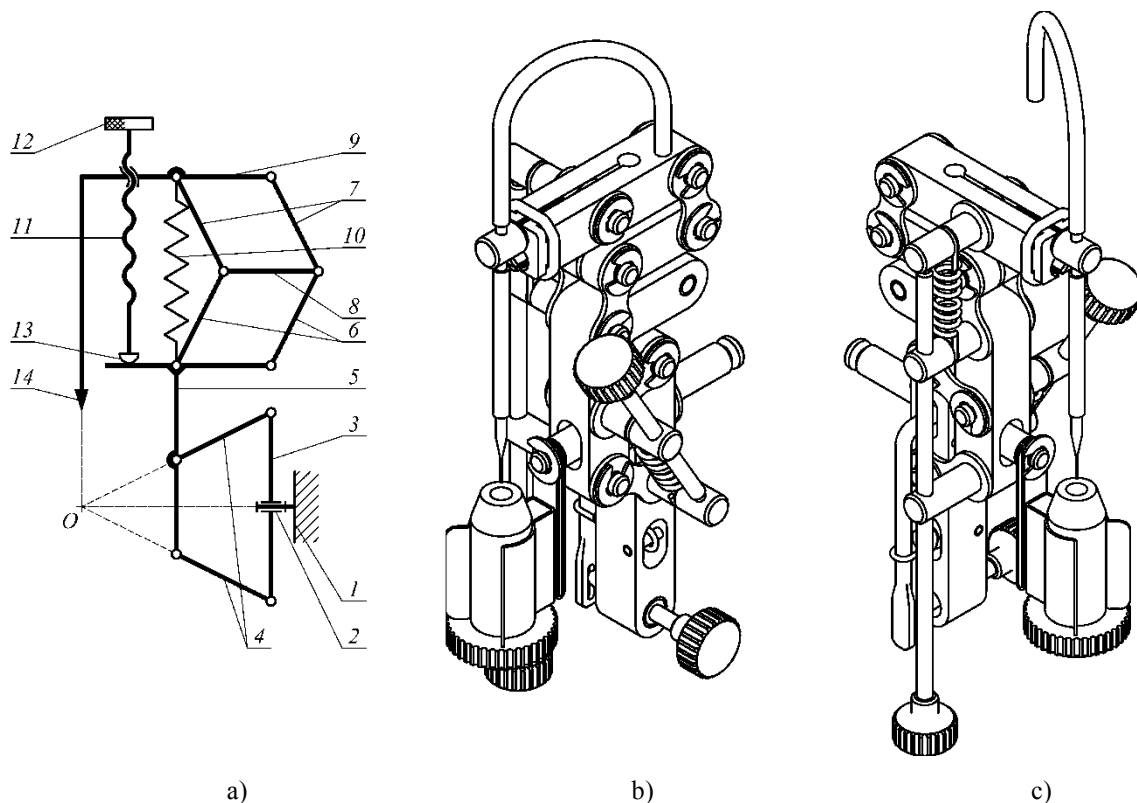

Figure 1. Micromanipulator based on the guide mechanisms

The working organ 14 (e.g., the microinjector capillary) is fixedly mounted on the connecting rod 9 and directed to the geometrical center *O* of the manipulator.

The design of the manipulator at least links 4 (4 pieces), 6 (3 pieces) and 7 (3 pieces) can be made equal, for example, in the form of links of sleeve or sleeve roller chains. Also expedient is manufacturing the link 8 from a chain links of the same size, thus reducing the range of parts.

The working organ rotation in a transverse vertical plane carried out by means a hinge 2 (the rotation drive is not shown) and requires no special explanation. The linear movement of working organ 14 is realized by rotation of hand wheel 12 from the screw mechanism 11. At this the working organ 14, which is mounted on the link 9 moves along a line passing through the geometric center *O* of the manipulator.

The inclination of working organ 14 is carried out by means of approaching or distancing the opposite hinge from four-link joints double lever mechanism which is made of

by a rotary frame 3, links 4 and the bottom of the L-shaped frames 5 (inclination drive is not shown).

Constructive realization of manipulator (as a satellite device for the method [7] and [8]) is shown in Fig. 1, *b* (the right front view) and *c* (the left front view) on which the chain links are well visible.

The use of commonly used rolling profiles and simplify the manufacturing process can be illustrated by a miniature guide for a straight motion [9].

The said miniature rectilinear guide includes an elongate tubular male and the female parts, which are interconnected with the possibility of mutual longitudinal motion only. The female part has at least one working portion formed in a regular triangular prism with a flat or concave faces. But a male part (in contact with the working portion of the female part) has a cross-sectional profile of a regular polyhedron with a number of sides that is a multiple of three.

Improving manufacturability of miniature straight guide is obtained at the expense of that one or more working parts of the female part may be formed by crimping a tubular work piece, for example, a self-centering three-jaw chuck (or other similar device), which are widely used in machine tools.

The male part, at least its working part, can be made from cold-hex calibrated rod. Thus, there is no need for additional parts that prevent mutual rotation of the male and female parts and simplifies the design and manufacturing of guide.

Improving the accuracy of positioning the working organ which is moved via guide, it is achieved by making the contacting surfaces of the male and female parts in the form of a right prism with a three multiples number of faces, which creates the effect of their self-centering.

Production of working portions of the female part by crimping create a smooth transition between the cylindrical and prismatic portions, reduces wear of working surfaces of parts during the operation of the guide, which also enhances the accuracy.

For cases where there is no need for any high precision, triangular prism faces of the female part 1 (Fig. 2, *a*) can be flat made. In this case the male 2 and female parts are aligned with a certain gap $\Delta \rightarrow 0$ between their faces.

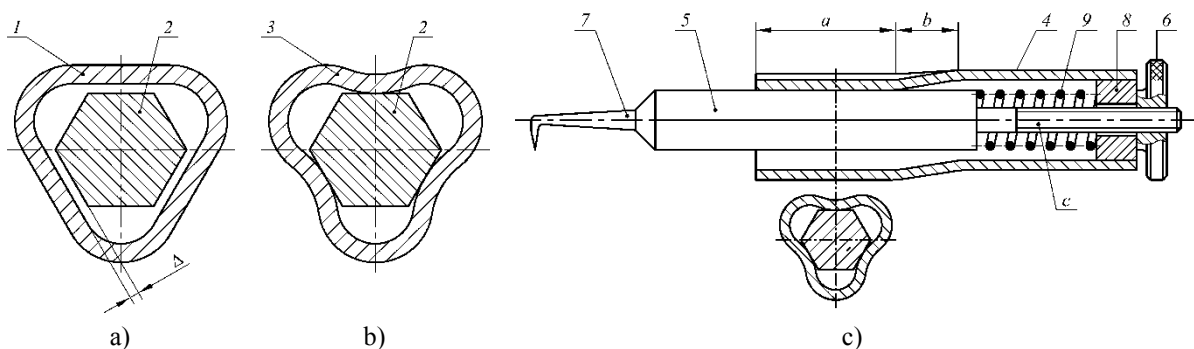

Figure 2. Miniature straight guide

To create accurate positioning triangular prism faces of the female part 3 (Fig. 2, *b*) can be made concave to create a pre-tension between the male 2 and female parts. Arising from this elastic force increase radial stiffness guide and give the effect of not only geometrical, but also force centering, this increases the overall accuracy of the positioning.

An example of the use of miniature linear guide may be a handheld straight motion mechanism (Fig. 2, *c*). The basis of the mechanism is the female part 4, which is formed of tubular work piece. The working surface is formed in the left side of her as a prism with concave faces on the portion *a*. The portion *b* is a transition between the cylindrical and prismatic

portions of the female part 4. The male part 5 is placed inside of the female part 4 with some preload, which is made of a hexagonal calibrated rolling profile (which is widely used in industry, such as making keys for screws with hexagon socket). In the right (rear) portion of the male part 5 is made a threaded portion c on which the sliding nut 6 is screwed. The left portion of the male part 5 is equipped with a working organ 7. The sliding nut 6 is in contact with bearing bush 8 on an end face, which is fixedly connected with the female part 4. Between the bearing bush 8 and working surface of the male part 5 is installed a coil spring 9 around the threaded portion.

The presence of the smooth transition b to avoid the intensive wear of the contacting surfaces of the parts 4 and 5, while improving the accuracy of the mechanism as a whole.

The using of elastic kinematical devices in micromechanism allows us to get some advantages:

- no clearance between the parts and caused by them dead zone;
- no friction surfaces and as a result, reducing abrade.

For example, 2DOF handheld micromanipulator [10] and [11] is based on compliant kinematical devices that is made from rod material. At low operating requirements of the micromanipulator as rod material can be used wedge key steel material. In micromanipulators flexure hinges are formed by removal of work piece material in designated places and subsequent plastic deformation to obtain the desired relative position of links.

Using as work piece material rod material with rectangular cross section can significantly simplify the design of the body of the device and improve its manufacturability. In this case, mechanical treatment is derived mainly to the cutting rod material, removal of work piece material to create areas of reduced rigidity, as well as some additional common operations, including cutting the thread. As the work piece can be used wedge key material with a square cross-section (up to 6 mm inclusive by most standards) or rectangular cross-section, and to create areas with reduced stiffness can be used milling operation to the passage, which also allows the processing simultaneously several pieces, which also improves manufacturability. The minimal cross size of the proposed micromanipulators are mainly determined by the size of the cross section of rod material.

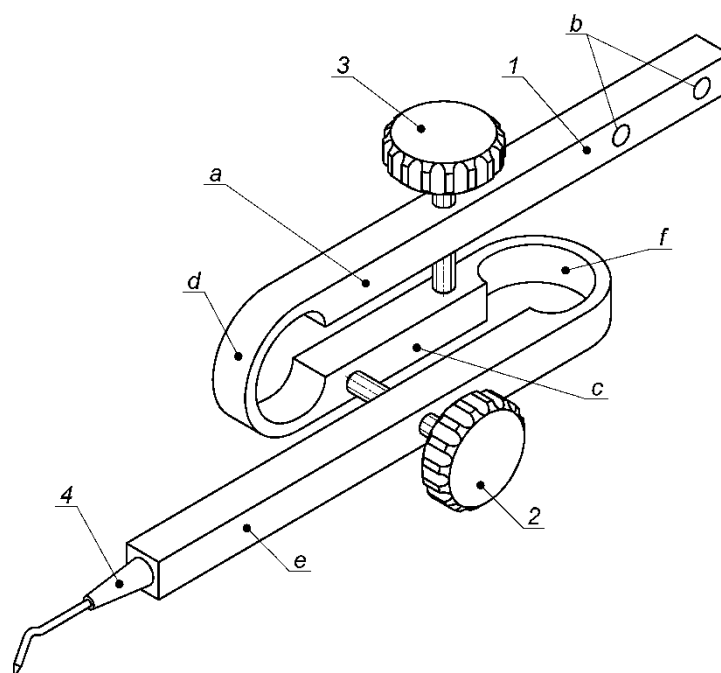

Figure 3. Orienting device (rod)

The basis of the micromanipulator is a body *l* (Fig. 3) which is made of rectangular rod material. The body contains the initial link *a*, in which has been processed the threaded hole for vertical movement screw 2, and fastening surface *b*, such as holes. An initial link *a* is connected to intermediaries link *c* with a flexure hinge *d*. An intermediate link *c* also is connected to the end link *e* with a flexure hinge *f*. End link *e* has a threaded hole for the horizontal displacement screw 3 and is equipped with a working organ 4. To the intermediate link *c* are touching the ends of screws 2 and 3. Areas of low stiffness are formed at a right angle to ensure the movement of working organ in two transverse directions.

After creating areas with reduced stiffness rods detail are bended on the midline these areas at an angle exceeding 180°, to the forming of irreversible plastic deformation. This is to ensure limited angular displacement respective links in the positive and negative directions relative to the neutral position, and to create tension and compensate for clearances in threaded and other contacting surfaces.

Micromanipulator works as follows. The working organ 4 is moved in a horizontal plane by a screw 2, and in the vertical plane by a screw 3, turning it in any direction. At small angular movements can be considered that working organ 4 has planar motion in a plane which is parallel to the axes of screws 2 and 3.

Also compliant kinematical element of the micromanipulator can be made of sheet material [10] and [12], which is widely used in industry for the manufacture of flat springs of devices, components of electrical automation and more.

Using a spring sheet material as the work piece material can significantly simplify the design of the body of the device and improve its manufacturability. In this case, mechanical treatment is derived mainly to contour cutting of sheet material that can be done by mechanical treatment (pressure or cutting) or physical-chemical methods (etching, electro erosion, radiation treatment, etc.).

The areas with reduced stiffness can be formed by one or more holes in the work piece material which are located such way that the cross section through the bending work piece is characterized by a significant twisting moment of inertia and relatively low moment of inertia relative to the fold.

Because the design of the device does not include translational kinematical pairs, then it is allowed a low accuracy of the shape, size and relative position of body contours of compliant kinematical device that increases the manufacturability of the design.

To increase the manufacturability of the device is advisable to use threaded rivets as threaded bushings which are widely available on the market. Threaded rivets are usually made of carbon steel, stainless steel and aluminum alloy.

The basis of the manipulator is a body *l* (Fig. 4) which is made of spring sheet material. The body contains the initial link *a*, in which the set threaded hub 6 for vertical movement screw 3 and is equipped with mounting surfaces *f*, such as holes. An initial link *a* is connected to intermediaries link *b* with a flexure hinge *e*. An intermediate link *b* also is connected to the end link *c* with a flexure hinge *d*.

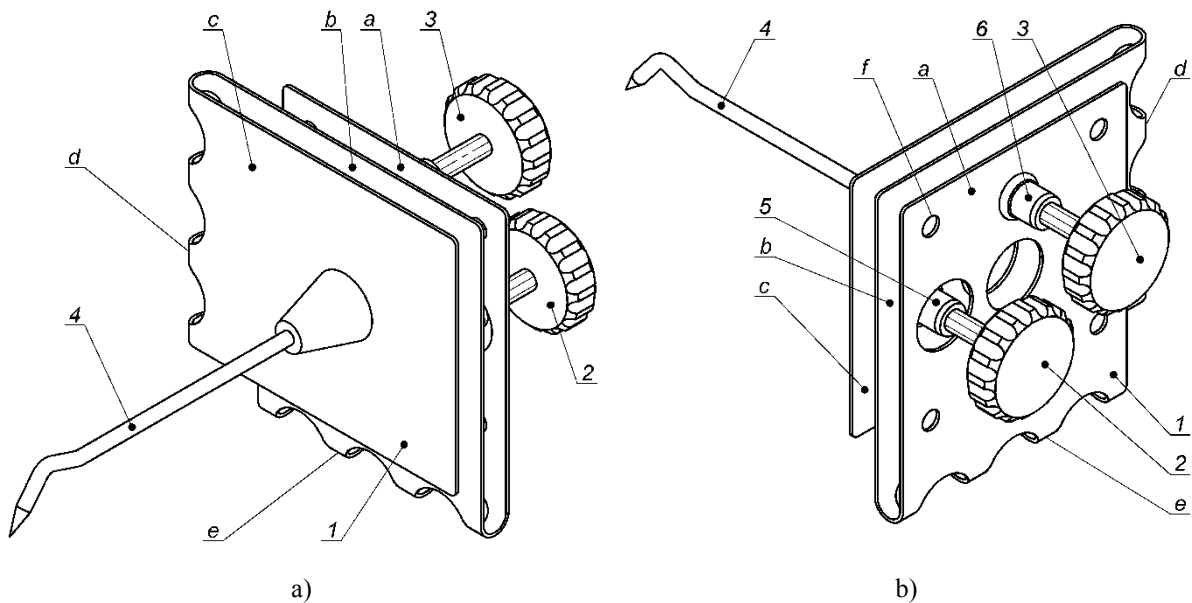

Figure 4. Orienting device (sheet)

In the end link *c* is set a threaded hub 5 for horizontal movement screw 2. End link *c* is also equipped with a working organ 4. To the intermediate link *b* are touching the ends of screws 2 and 3. Areas of low stiffness are formed at a right angle to ensure the movement of working organ in two transverse directions.

After creating areas with reduced stiffness rods detail are bended on the midline these areas at an angle exceeding 180° , to the forming of irreversible plastic deformation. This is to ensure limited angular displacement respective links in the positive and negative directions relative to the neutral position, and to create tension and compensate for clearances in threaded and other contacting surfaces. At small angular movements can be considered that working organ 4 has planar motion in a plane which is perpendicular to the axes of screws 2 and 3.

Presented micromanipulators with compliant kinematical devices, in addition to these advantages are quite insensitive to dust and other pollution. Also, they do not have the critical shortage or complete absence of lubricating friction surfaces.

Conclusions. Presented ways to create commercially attractive micromanipulators to manipulate tiny objects, including biological living objects, are not exhaustive. Great interest are the newest promising technologies, including 3D printing, including and the metallic.

However, even these several ways will develop to manufacture micromanipulators for any type of production.

A promising direction for further research and development is unification of parts (assembly units) and development of a modular principle of construction of technological equipment with the use presented micromechanisms.

In addition, in market economy and competition, it is appropriate not create inexpensive non-separable designs of micromanipulators with hidden structure.

References

1. Кеpeña Ladislav. Inseminácia včelích miatek veľkokapacitným insemináčným prístrojom. Bratislava, 1988. [In Czech].
2. Ruttner F. Instrumental'noe osemenenie pchelinyx matok. Per. s nem., izd. 2-e. Buxarest, Apimondiia, 1975, 128 p. [In Russian].
3. Brovarkii V. Sposib shtuchnoho osimeninnia bdzholynykh matok. Patent of Ukraine for invention

- no. 50846 IPC A01K 47/00. Request no. 2000031250 from 02.03.2000. Published 15.11.2002, Bulletin vol. 11. [In Ukrainian].
4. Samoilenko O. Trokhkoordinatnyi manipulator z vykorystanniam lantsiuhovykh lanok. Materialy Mizhnarodnoi naukovo-tekhnichnoi konferentsii „Problemy suchasnykh tekhnolohii vyhotovlennia ta nadiinosti peredach z hnuchkym zviazkom“, prysviachenoj pam'iaty ta 70-y richnytsi z dnia narodzhennia profesora Dubyniaka Stepana Andriiovycha. Ternopil, 2011, pp. 73 – 75. [In Ukrainian].
 5. Samoilenko O. Manipulator. Patent of Ukraine for utility model no. 59708 IPC B25J 1/00, B25J 7/00. Request no. u201013479 from 15.11.2010. Published 25.05.2011, Bulletin vol. 10/2011. [In Ukrainian].
 6. Samoilenko O. The device for artificial insemination of queen bees. XXXXIII International Apicultural Congress. Kyiv, 2013, pp. 313 – 314.
 7. Brovarskii V.D. Obgruntuvannia tekhnolohii reproduksii bdzholynykh matok. Diss. dokt. s.-h. nauk. Kyiv, 2006, 431 p. [In Ukrainian].
 8. Brovarskii V., Samoilenko O. Sposib otrymannia plidnykh bdzholynykh matok. Patent of Ukraine for invention no. 98425 IPC A01K 49/00, A01K 67/033, A61D 19/02. Request no. a201107077 from 06.06.2010. Published 10.05.2012, Bulletin vol. 9/2012. [In Ukrainian].
 9. Samoilenko O. Napriamna priamoliniina miniatiurna. Patent of Ukraine for utility model no. 60261 IPC F16C 29/00. Request no. u201015337 from 20.12.2010. Published 10.06.2011, Bulletin vol. 11/2011. [In Ukrainian].
 10. Samoilenko O. Low Cost Handheld Micromanipulators Based on Compliant Kinematic Devices. Technological complexes. Vol. 1/2 (12), 2015, pp. 26 – 32.
 11. Samoilenko O. Oriientuiuchy prystrii (prutkovyi). Patent of Ukraine for utility model no. 102100 IPC B25J 1/00, B25J 7/00. Request no. u201504934 from 20.05.2015. Published 12.10.2015, Bulletin vol. 19/2015. [In Ukrainian].
 12. Samoilenko O. Oriientuiuchy prystrii (lystovyi). Patent of Ukraine for utility model no. 102101 IPC B25J 1/00, B25J 7/00. Request no. u201504935 from 20.05.2015. Published 12.10.2015, Bulletin vol. 19/2015. [In Ukrainian].

Список використаної літератури

1. Керепа Ladislav. Inseminacia včelích miatek vel'kokapacitným inseminacným prístrojom. Bratislava, 1988.
2. Рутгнер, Ф. Инструментальное осеменение пчелиных маток [Текст] / Ф. Рутгнер, пер. с нем., изд. 2-е. – Бухарест: Изд-во Международного института технологии и экономики пчеловодства Апимондии, 1975. – 128 с.
3. Броварський, В.Д. Спосіб штучного осіменіння бджолиних маток [Текст] / В.Д. Броварський // Патент України на винахід №50846 МПК А01К 47/00; №2000031250 від 02.03.2000 р.; опубл. 15.11.2002 р., Бюл. №11.
4. Самойленко, О.В. Трьохкоординатний маніпулятор з використанням ланцюгових ланок [Текст] / О.В. Самойленко // Матеріали Міжнародної науково-технічної конференції «Проблеми сучасних технологій виготовлення та надійності передач з гнучким зв'язком», присвяченої пам'яті та 70-й річниці з дня народження професора Дубиняка Степана Андрійовича (Україна, м. Тернопіль, 19... 21 грудня, 2011 р.). – Тернопіль: Крок, 2011. – 126 с. – С. 73 – 75.
5. Самойленко, О.В. Маніпулятор [Текст] / О.В. Самойленко // Патент України на корисну модель №59708 МПК В25J 1/00, В25J 7/00; №u201013479 від 15.11.2010 р.; опубл. 25.05.2011, Бюл. №10/2011.
6. Samoilenko O. The device for artificial insemination of queen bees. XXXXIII International Apicultural Congress. Kyiv, 2013, pp. 313 – 314.
7. Броварський, В.Д. Обгрунтування технології репродукції бджолиних маток : дис. д-ра с.-г. наук: 06.02.04 [Текст] / В.Д. Броварський. – Національний аграрний ун-т. – К., 2006. – 431 с.
8. Броварський, В.Д. Спосіб отримання плідних бджолиних маток [Текст] / В.Д. Броварський, О.В. Самойленко // Патент України на винахід №98425 МПК А01К 49/00, А01К 67/033, А61D 19/02; №a201107077 від 06.06.2010 р.; опубл. 10.05.2012 р., Бюл. №9/2012.
9. Самойленко, О.В. Напрямна прямолинійна мініатюрна [Текст] / О.В. Самойленко // Патент України на корисну модель №60261 МПК F16C 29/00; №u201015337 від 20.12.2010 р.; опубл. 10.06.2011 р., Бюл. №11/2011.
10. Samoilenko O. Low Cost Handheld Micromanipulators Based on Compliant Kinematic Devices.

Technological complexes. Vol. 1/2 (12), 2015, pp. 26 – 32.

11. Самойленко, О.В. Орієнтуючий пристрій (прутковий) [Текст] / О.В. Самойленко // Патент України на корисну модель №102100 МПК В25J 1/00, В25J 7/00; №u201504934 від 20.05.2015 р.; опубл. 12.10.2015 р., Бюл. №19/2015.
12. Самойленко, О.В. Орієнтуючий пристрій (листовий) [Текст] / О.В. Самойленко // Патент України на корисну модель №102101 МПК В25J 1/00, В25J 7/00; №u201504935 від 20.05.2015 р.; опубл. 12.10.2015 р., Бюл. №19/2015.

УДК 621.865.8

ПИТАННЯ ПІДВИЩЕННЯ ТЕХНОЛОГІЧНОСТІ ПРИСТРОЇВ ДЛЯ МАНІПУЛЮВАННЯ МІНІАТЮРНИМИ ОБ'ЄКТАМИ

Олексій Самойленко

*Національний технічний університет України «Київський політехнічний
інститут імені Ігоря Сікорського», Київ, Україна*

Резюме. Розглянуто питання створення елементної бази мікроманіпуляторів, які б відповідали ряду вимог, зокрема технологічність, можливість ручного керування, стійкість до негативного впливу середовища, а також можливість повної або часткової стерилізації та захищеність від завідомо невірних дій оператора. Запропоновано побудову елементів мікроманіпуляторів із використанням ланок приводних ланцюгів, поширених прокатних профілів на основі пружних кінематичних пристроїв із використанням поширених пруткового та листового матеріалів. Означені пропозиції проілюстровано власними розробками автора, захищеними патентами.

Ключові слова: мікроманіпулятор, маніпулювання, ручне керування, направляючий механізм; приводний ланцюг, прокатний профіль, пружний кінематичний пристрій, пружний шарнір, ступені свободи, прутковий матеріал, листовий матеріал.

Отримано 06.09.2017