



UDC 621.9

## DECREASE OF SURFACES ROUGHNESS FOR PARTS PROCESSED WITH EDGE TOOL BY IMPROVEMENT OF THE LATHE WORKING COMPONENTS UNIFORM FEED

Yaroslav Stephyn; Valentyn Otamanskyi

*Zhytomyr State Technological University, Zhytomyr, Ukraine*

**Summary.** *The relative motion smoothness of the tool and processing workpiece has an essential influence on the quality of the edge tool processing. The analyses of the process of the surface roughness formation on the parts processed with an edge tool under the influence of vibration movement of the metal-cutting lathes working components is carried out in this paper. The methods of prediction of the geometric parameters of the part surface quality are considered. It is determined here that the intensity of non-uniform metal-cutting lathe slide movement depends on the guide operating mode, that is, the conditions under which the friction of two surfaces occurs at their relative movement. Mixed friction influences the working components uniform motion the most negatively. In order to improve the uniform metal-cutting lathe support movement at light (fine) feeds it is suggested to go into guide dry (limiting) friction performing the processing with the additional loading of the working component. The results of the researches carried out under the working component loading connected with the influence of non-uniform support feed on the processed surface roughness are described. It was determined during the investigations that the stick-slip motion at light feeds of metal-cutting lathes working components is less intensive and the surface roughness of processed parts is improved.*

**Key words:** *feed movement non-uniformity, surface roughness, edged tool processing, vibrations; friction; turning machine.*

*Received 14.11.2017*

**Statement of the problem.** The surface roughness significantly affects the parts operational capabilities. Production of necessary surfaces roughness of the parts processed on metal-cutting lathes is possible only by providing the cutting process consistency. Random variations in technological systems result in deterioration of the surface geometric quality.

One of the reasons for the rejection of the tool shaping motion in relation to the workpiece is the stick-slip motion of the metal cutting lathe support (table). While cutting, the stick-slip motion of the lathe working components changes the feed rate, hence affecting the processed surface roughness, increasing it in several times. The main factors which also influence the parts surfaces roughness are [1, 2, 3, 4]:

- geometric copying of the tool working part in the workpiece material;
- vibrational movement of the instrument relative to the workpiece;
- elastic-plastic deformation of the surface layer of the processed material;
- occasional discontinuities of the treated material from the treated surface;
- distortion of microirregularities by chips convergence.

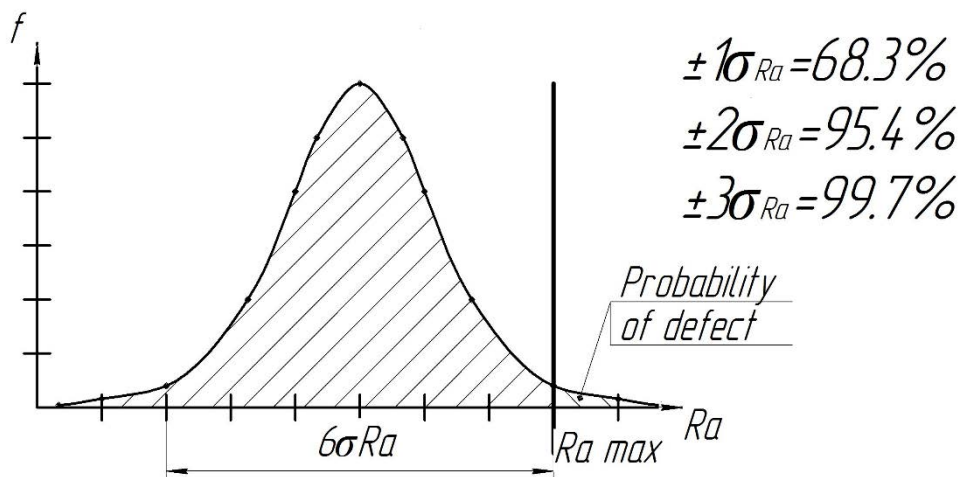
The main measures to reduce the working components non-uniform feed are as follows [4, 5, 6, 7]:

- operation at working component motion speeds which are much higher than critical speed;
- use of friction couple with favourable characteristics;
- use of special lubricants to reduce the difference between the coefficients of static and kinematic friction;
- unloading of sliding guides due to rollers and whippet tanks, hydraulic and pneumatic unloading;
- increase of the drive feed rigidity;

- use of special of precise microdisplacement drives allowing controlled microdisplacement.

**Analysis of available investigations and publications.** Determination of roughness parameters (for example: arithmetic mean deviation of profile –  $R_a$ ) according to DSTU 2413-94 is based on the profilograms processing. Usually the surface roughness is measured along and across the detail processing traces, and the values obtained are distributed in a certain quantities range. In fact, while processing the parts on metal-cutting lathes, the microirregularities height value depends on many probabilistic quantities. To analyze the surface roughness while processing several parts at different processing modes or under different processing conditions, it is efficient to use the magnitude normal distribution law.

Fig. 1 shows the curve of the roughness parameter  $R_a$  normal distribution. If the value  $R_{a\ max}$  is set by the designer according to the drawing specification, the condition  $R_a \leq R_{a\ max}$  is possible only with a certain probability determined by the area under the curve on the left to the value  $R_{a\ max}$ . Relatively the area of the right side determines the possibility of the defect [8].



**Figure 1.** The calculation of roughness defect possibility

As it is well-known [9, 6, 10, 11, 12], friction in sliding guides is one of the factors determining the load on all elements of the drive feed, the engine power, the accuracy and uniformity of the working components movement and the efficiency and durability of the guides themselves. Typically, the calculation of guides is carried out at the permissible values of the specific load and sliding velocity without actual friction conditions.

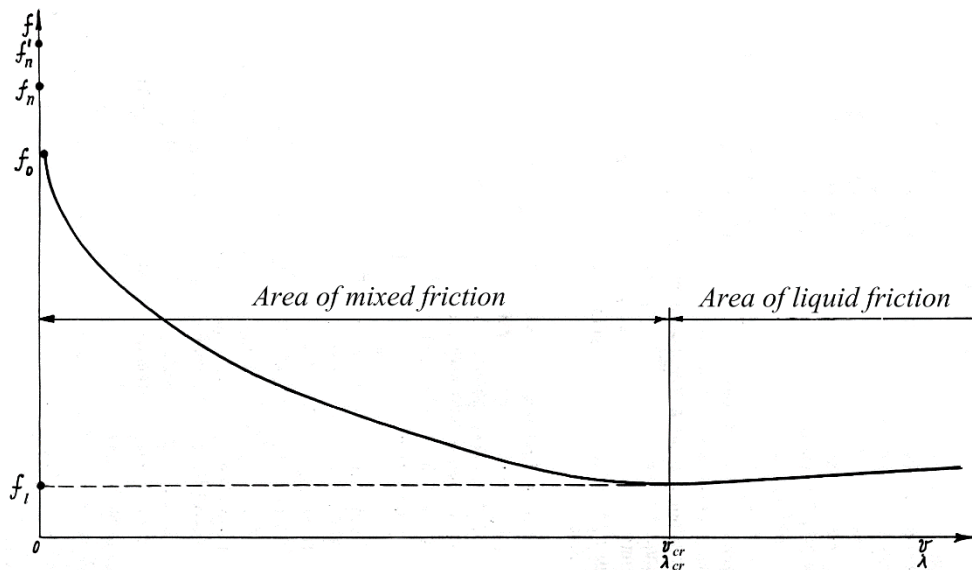
Sliding guides tend to work in the mixed friction mode where the lubricating fluid does not completely divide the rubbing surface. The area of mixed friction is characterized by a large variety of conditions of the surfaces operation under their relative displacement, depending on the proportion of dry, boundary and liquid friction. In the area of mixed friction a significant role is played by hydrodynamic phenomena. Therefore, increase of the slip speed, viscosity of the lubricant and reduction of the specific load result in the decrease of strength and friction coefficient.

At given  $\mu$  and  $\rho$  the critical characteristic of guides  $\lambda_{cr}$  operation at which guides start to operate in the liquid friction mode corresponds to critical speed  $\vartheta_{cr}$ . The conditions of the guides operation can be determined by the ratio  $\frac{\lambda}{\lambda_{cr}}$ , which shows how much the given mode of operation is close to the critical one.

$$\lambda = \frac{\mu \cdot \vartheta}{\rho}, \quad (1)$$

where  $\lambda$  – being the characteristic of the operating mode;  $\rho$  – being the average specific load;  $\vartheta$  – being the slip speed;  $\mu$  – being the lubricant viscosity.

To ensure the uniform movement of the lathe working components along the sliding guides the difference between static and dynamic friction coefficients should be as small as possible. For guides the kinematic coefficient of friction  $f$  depends on the operating mode characteristics according to the dependence shown in Fig. 2 [6], where:  $f_n$  – being the coefficient of friction of rest at the small time of the fixed contact;  $f'_n$  – being the coefficient of friction of rest at the long time of a fixed contact;  $f_0$  – being the coefficient of friction, which corresponds to the value of relatively low slip speed;  $f_l$  – being the coefficient of friction, which corresponds to the critical value of the operating mode characteristics  $\lambda_{cr}$  from which liquid friction occurs.

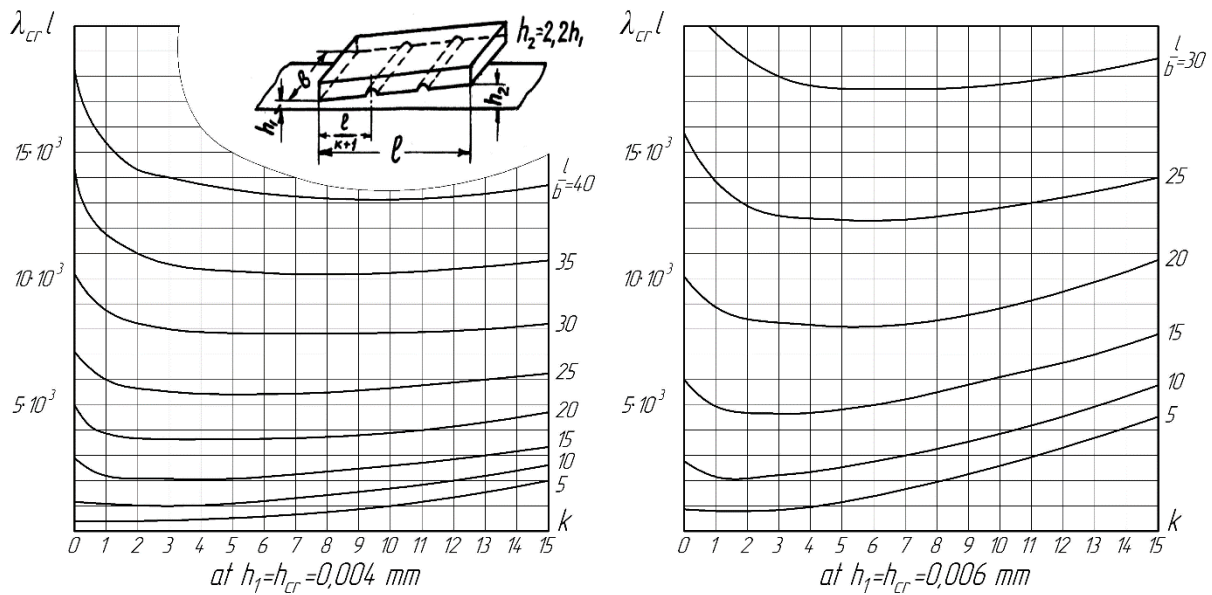


**Figure 2.** The curve of dependence of the coefficient of friction on the speed of sliding

When the speed value reaches the critical one, the friction coefficient reaches the minimum ( $f = f_l$ ). The value  $v_{cr}$  corresponds to the beginning of the boundary of liquid friction, which depends on the guides material and dimensions, the accuracy in the purity of the friction surfaces, the size and location of the displaced grooves, the viscosity of the lubricant, the specific load, etc.

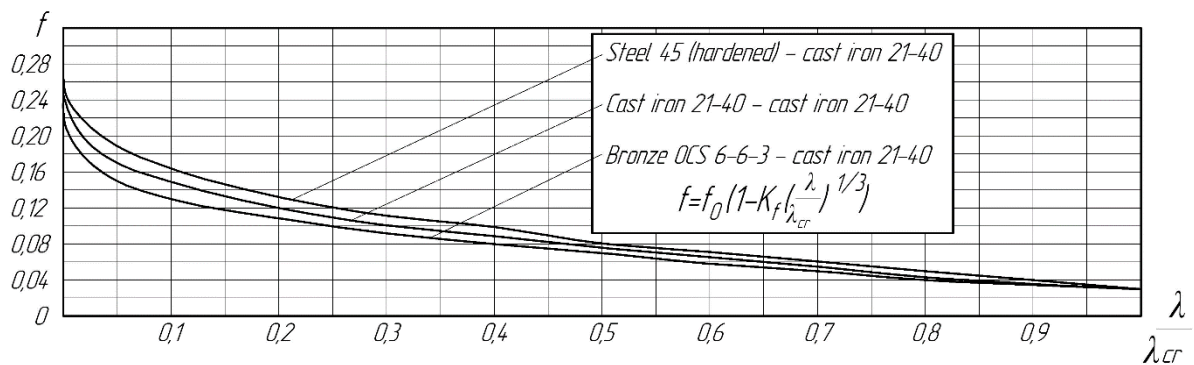
Reduction of the friction coefficient with slip speed increase is connected with the increase in hydrodynamic lift power [6, 7]. For the purpose of this force occurrence it is necessary to vary the thickness of the lubricating layer along the support length. It was proved experimentally that the main reason of the hydrodynamic pressure occurrence in the guides was small rotation of the table (support) in the vertical plane producing the wedge between the friction surfaces. This rotation occurs even when the load is located in the unfavourable position.

The critical characteristic  $\lambda_{cr}$  depends on the guides dimensions, the number of cross grooves and the thickness of the lubricant layer between the friction surfaces and can be determined by the graphs [6], (Fig. 3).



**Figure 3.** The dependence of  $\lambda_{cr} \cdot l$  on the number of cross grooves  $k$  on the guides for different ratio  $\frac{l}{b}$

The dependence of the friction coefficient  $f$  on the relative characteristics of the guides operation mode [6] is shown in Fig. 4.



**Figure 4.** The dependence of the friction rate on the relative characteristics of working conditions of the guides

Thus, the work of the sliding guides in the mixed friction mode in which the lubricant does not completely divide the rubbing surface, is not desirable, as it results in constant friction coefficient change and consequently the working component does not move uniformly. Therefore, the support should be either unloaded and transferred to the area of liquid friction or loaded and transferred to the area of dry friction.

In paper [7] Push V. Ye. suggests the formula for the critical velocity  $V_{cr}$  calculation, the slick-slip motion of the working component occurs below it:

$$V_{cr} = \frac{\Delta f \cdot N}{\sqrt{4 \cdot \pi \cdot \theta \cdot \sqrt{k \cdot m}}}, \quad (2)$$

where  $\Delta f = f_0 - f$  is the difference between coefficients of friction of rest and motion;  $N$  is the normal force on guides;  $4 \cdot \pi \cdot \theta$  - is the relative energy dissipation at oscillations;  $k$  is the drive rigidity;  $m$  is the mass of the moving unit.

As can be seen from the formula, the increase of the working component mass results in the decrease of the critical speed, in addition, the movement friction coefficient increases resulting in  $\Delta f$  decrease.

**Statement of the main material.** The purpose of this work is the investigation of the working component movement uniformity by its loading with additional effort. When the mass of the working component increases, the intensity of guides wear [11, 12, 13] increases. It is the negative feature of this method of the parts processing. It can be characterized by the formulas (3, 4 and 5):

$$U = k \cdot p^m \cdot v \cdot t - \text{surface linear wear,} \tag{3}$$

$$\gamma = U/t = k \cdot p^m \cdot v - \text{surface wear speed,} \tag{4}$$

where  $k$  is wear coefficient;  $p$  is pressure on the friction surface, Pa;  $v$  is the speed of relative sliding, m / s;  $t$  is operation time;  $m$  is the coefficient,  $m = 1$  for abrasive wear type.

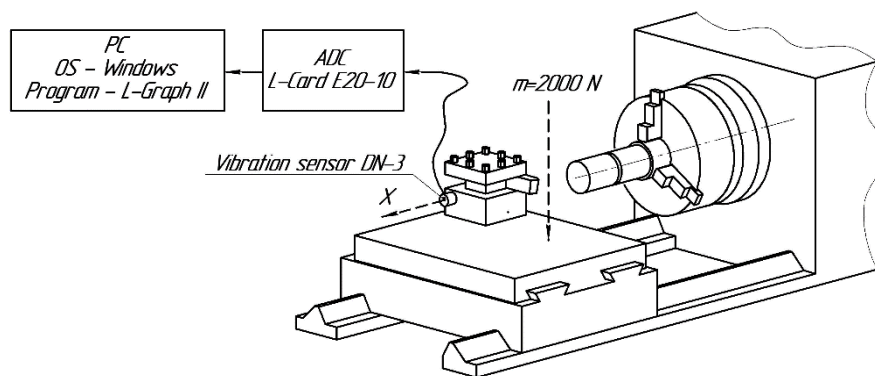
$$U(x) = k \cdot s \int_{l_1}^{l_2} \varphi(x - 1) \cdot f(l) dl . \tag{5}$$

$U(x)$  is the value of linear wear of guide racks in length  $x$  at  $0 \leq x \leq (L + l_0)$ ;  $L$  is the maximum support speed;  $l_0$  is the length of the support guides.

So this method should be used only at low speeds of the metal-cutting lathes support (table) where the stick-slip movement and unloading at high speeds and at accelerated working component movement take place.

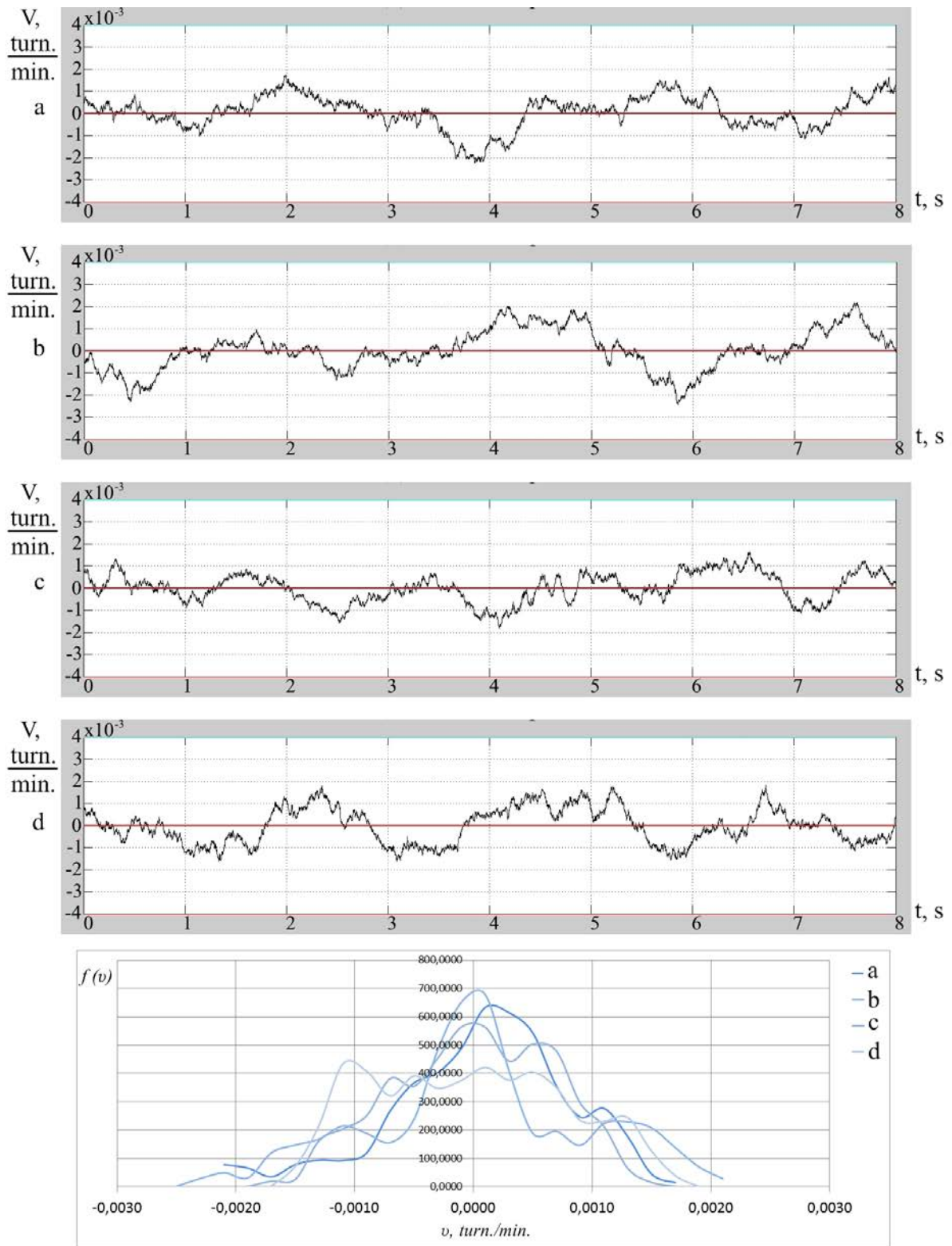
The research was carried out on a lathe-screw machine of the mod. KA-280. The experiment where the turning process of 2 groups of workpieces (Steel 40), 40 mm in diameter with cutting modes:  $n = 630$  rpm,  $S = 0,05$  mm / rev,  $t = 0,2$  mm was carried out. The first group of workpieces was turned without load, and the second - under the load of the support mass – 200 kg.

The control of research results was carried out using a set of devices including: piezoelectric vibration sensor DN-3; analogue-digital converter (ADC) E20-10 produced by the firm L-Card; personal computer with the installed L-Graph II program for recording and processing data.

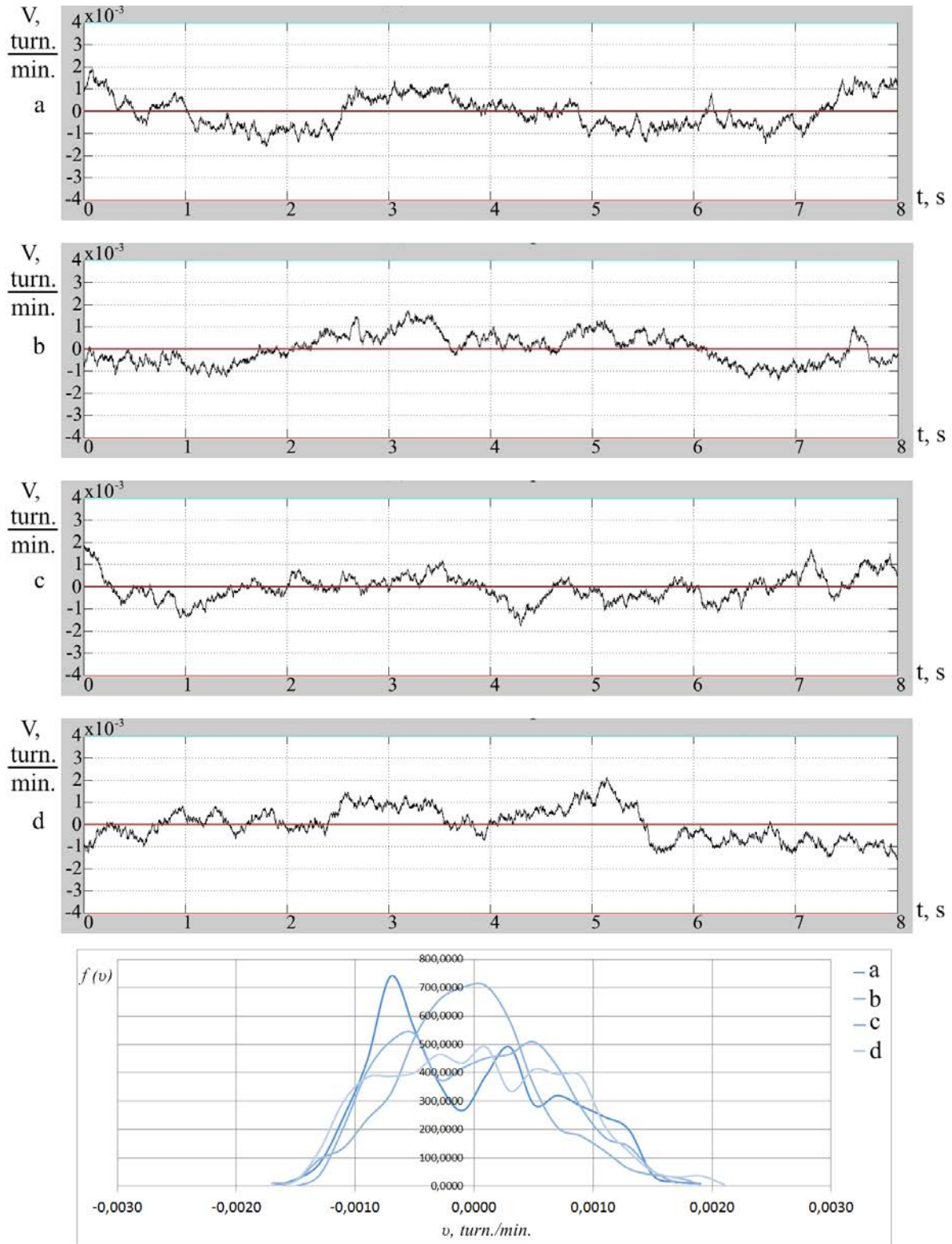


**Figure 5.** The diagram of the unit for researches

Mathematical model for recorded vibrations processing was developed using the SIMULINK visual simulation system in the MATLAB program. The test sample of the results is shown in Fig. 6 and Fig. 7 in the form of graphs of vibration speed.



**Figure 6.** The obtained diagrams of vibration speed (the load is 0 N)



**Figure 7.** The obtained diagrams of vibration speed (the load is 2000 N)

After the experiment the surface roughness was measured by means of Surtronic 10 profilometer, and the normal distribution curves without support (0 N) load and with additional support load of 2000 N were developed (Fig. 8).

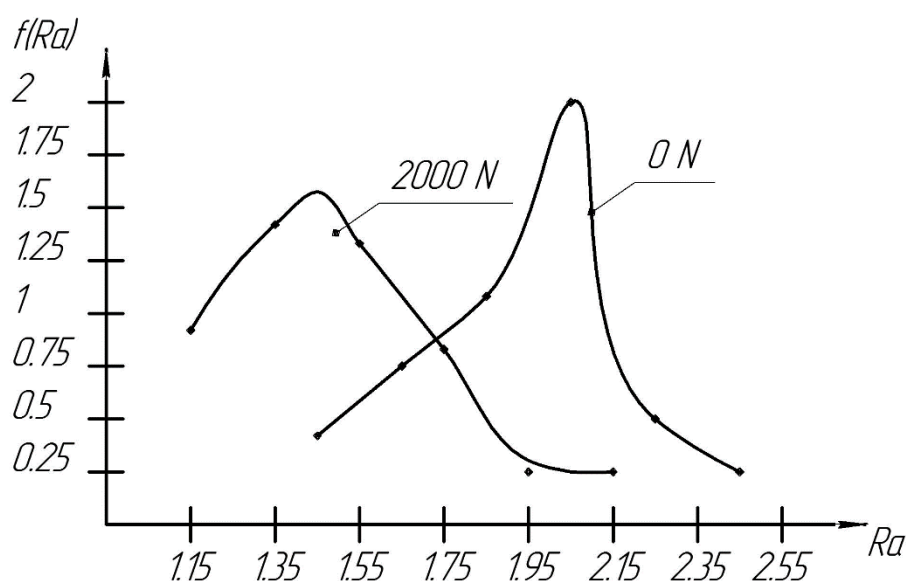


Figure 8. The scattering of the meanings of the surface roughness  $R_a$

From the obtained results it can be seen that when the weight of the support is increased by the additional mass, the uniformity of the movement is improved. The measured roughness of the obtained parts decreased by 30%, but the values scattering field increased by 25%.

**Conclusions.** A new method of processing is suggested: the working component loading by additional effort, which reduces the difference between static and dynamic coefficients of friction.

The developed curves of normal distribution proved that the processing parts roughness under the support load has decreased by 30%.

The method of the working component loading by additional effort should be used only at low speeds of the metal-cutting lathe support (table) where stick-slip movement occurs, and unloaded at high speeds and at the accelerated movement of the working component.

#### References

1. Klimenko S.A. Formirovanie mikronerovnostej poverxnosti pri obrabotke pokrytij lezviynym instrumentom. Sb. nauch. Tr., NAN Ukrainy. Institut sverxtverdyx materialov, Kiev, 1998, pp. 26 – 33 [in Russian].
2. Klimenko S.A. K voprosu o mexanizme formirovaniya mikrogeometrii poverxnosti pri lezviynoj obrabotke. Sverxtvyordye materialy, No. 5, 1997, pp. 43 – 53 [in Russian].
3. Suslov A.G. Teknologicheskoe obespechenie parametrov sostoyaniya poverxnostnogo sloya detalej, Moscow: Mashinostroenie, 1987. 208 p. [in Russian].
4. P.P. Melnichuk, O.O. Vynogradov, V.E. Loiev, V.V. Otamanskyi. Research was undertaken to study the influence of nonuniformity motion during supply to the surface roughness on details, processed with an edge tool, Visnyk ZhDTU. Tekhnichni nauky, 2015, Vol. 75, No. 4, pp. 13 – 22.
5. Belyakovskij V.P., Kipcharskij S.V. Analiz prichin, opredelyayushhix pogreshnosti pozicionirovaniya rabochix organov stankov s ChPU. Visnyk Pryazovskoho derzhavnogo tekhnichnoho universytetu : zb. naukovykh prats, PDTU, Mariupol, 2011, Vol. 23, No. 2, pp. 203 – 209 [in Russian].
6. Levit G.A., Lure B.G. Opredelenie poter v elementax privodov podach stankov i raschet napravlyayushhix skolzheniya po karakteristikam treniya. Rukovodyashhie materialy. Mossow: ENIMS, 1961, 89 p. [in Russian].
7. Push V.E. Malye peremeshheniya v stankax. Mossow: Mashgiz, 1961, 124 p. [in Russian].



8. Leonov S.L., Goncharov V.D. Metodologicheskie osnovy prognozirovaniya geometricheskikh parametrov kachestva poverkhnosti detail. Sborniki nauchnykh работ NTU "XPI": Suchasni tekhnolohii v mashynobuduvanni, No. 4, 2010, ISSN 2078-7499 [in Russian].
9. Gitis N.V., Chizhov N.C., Vliyanie kontaktnogo davleniya na antiskachkovye svoystva napravlyayushhix skol'zheniya, Stanki i instrument, No. 1, 1987, pp. 13 – 15 [in Russian].
10. Orlikov M.L. Dinamika stankov. Kyiv: Vyshcha shkola, 1980, 256 p. [in Russian].
11. Pronikov A.S., Proektirovanie metallorazreshhix stankov i stanochnykh sistem: Spravochnik-uchebnik. V 3-x t., Moscow: Mashinostroenie, 1994 [in Russian].
12. Push V.E. Konstruirovaniye metallorazreshhix stankov, Moscow: Mashinostroenie, 1987, 390 p. [in Russian].
13. Loiev V.Yu., Leshchenko B.M., Tymoshchuk A.M., Zv'язok mikroreliefu poverkhon par tertia z intensyvniстю yikh znoshuvannia pry nestatsionarnykh umovakh ekspluatatsii. Visnyk ZhDTU. Tekhnichni nauky, 2017, Vol. 79, No. 1, pp. 23 – 35 [in Ukrainian].

### Список використаної літератури

1. Клименко, С.А. Формирование микронеровностей поверхности при обработке покрытый лезвийным инструментом: сб. науч. тр. [Текст] / С.А. Клименко // НАН Украины. Институт сверхтвердых материалов. – Киев, 1998. – С. 26 – 33.
2. Клименко, С.А. К вопросу о механизме формирования микрогеометрии поверхности при лезвийной обработке, [Текст] / С.А. Клименко // Сверхтвердые материалы. – 1997. – № 5. – С. 43 – 53.
3. Суслов, А.Г. Технологическое обеспечение параметров состояния поверхностного слоя деталей [Текст] / А.Г. Суслов. – М.: Машиностроение, 1987. – 208 с.
4. Research was undertaken to study the influence of nonuniformity motion during supply to the surface roughness on details, processed with an edge tool / P.P. Melnichuk, O.O. Vynohradov, V.E. Loiev, V.V. Otamanskyi // Вісник ЖДТУ. – Технічні науки. – 2015. – № 4 (75). – Р. 13 – 22.
5. Беляковский, В.П. Анализ причин, определяющих погрешности позиционирования рабочих органов станков с ЧПУ, [Текст] / В.П. Беляковский, С.В. Кипчарский // Вісник Приазовського державного технічного університету : зб. наукових праць / ПДТУ. – Маріуполь, – 2011. – № 2 (23). – С. 203 – 209.
6. Левит, Г.А. Определение потерь в элементах приводов подач станков и расчет направляющих скольжения по характеристикам трения. Руководящие материалы [Текст] / Г.А. Левит, Б.Г. Лурье. – М.: ЭНИМС, 1961. – 89 с.
7. Пуш, В.Э. Малые перемещения в станках [Текст] / В.Э. Пуш. – М.: Машгиз, 1961. – 124 с.
8. Леонов, С.Л. Методологические основы прогнозирования геометрических параметров качества поверхности детали [Текст] / С.Л. Леонов, В.Д. Гончаров // Сборники научных работ НТУ "ХПИ": Сучасні технології в машинобудуванні. – № 4 – НТУ – "ХПИ", 2010.
9. Гитис, Н.В. Влияние контактного давления на антискачковые свойства направляющих скольжения [Текст] / Н.В. Гитис, Б.Н. Чижов // Станки и инструмент. – 1987. – № 1. – С. 13 – 15.
10. Орликов, М. Л. Динамика станков [Текст] / М.Л. Орликов. – К. : Вища школа, 1980. – 256 с.
11. Проников, А. С. Проектирование металлорежущих станков и станочных систем: Справочник-учебник. В 3-х т. [Текст] / А.С. Проников. – М.: Машиностроение, 1994.
12. Пуш, В.Э. Конструирование металлорежущих станков [Текст] / В.Э. Пуш. – М.: Машиностроение, 1987. – 390 с.
13. Лоев, В.Ю. Зв'язок мікрорельєфу поверхонь пар тертя з інтенсивністю їх зношування при нестационарних умовах експлуатації [Текст] / В.Ю. Лоев, Б.М. Лещенко, А.М. Тимошук // Вісник ЖДТУ. – Технічні науки. – 2017. – № 1 (79). – С. 23 – 35.

УДК 621.9

**ЗМЕНШЕННЯ ШОРСТКОСТІ ПОВЕРХОНЬ ДЕТАЛЕЙ,  
ОБРОБЛЕНИХ ЛЕЗОВИМ ІНСТРУМЕНТОМ ШЛЯХОМ  
ПОКРАЩЕННЯ РІВНОМІРНОСТІ  
ПОДАЧІ РОБОЧИХ ОРГАНІВ ВЕРСТАТІВ**

**Ярослав Степчин; Валентин Отаманський**

*Житомирський державний технологічний університет,  
Житомир, Україна*

***Резюме.** Виконано аналіз процесу утворення шорсткості поверхонь деталей, оброблених лезовим інструментом під впливом вібраційного переміщення робочих органів металорізальних верстатів. Розглянуто методи прогнозування геометричних параметрів якості поверхонь деталей. Визначено, що інтенсивність нерівномірного переміщення супорту (столу) металорізального верстата залежить від режиму роботи напрямних, тобто в яких умовах проходить тертя двох поверхонь при їх відносному переміщенні. Змішане тертя найбільш негативно впливає на рівномірність руху робочих органів. Для покращення рівномірності руху супорту (столу) металорізальних верстатів на малих (чистових) подачах запропоновано переходити в сухий (граничний) режим тертя напрямних, проводячи обробку з додатковим навантаженням робочого органу. Наведено результати проведених досліджень під навантаженням робочого органу, пов'язаних із впливом нерівномірності подач супорта (столу) на шорсткість обробленої поверхні. В ході досліджень встановлено, що стрибкоподібний рух на малих (чистових) подачах робочих органів металорізальних верстатів менш інтенсивний, тому шорсткість поверхні оброблених деталей покращується.*

***Ключові слова:** нерівномірність руху подачі, шорсткість поверхні, обробка лезовим інструментом, вібрації, тертя, токарний верстат.*

*Отримано 14.11.2017*