

НЕТРАДИЦІЙНІ ВИДИ ТРАНСПОРТУ. МАШИНИ ТА МЕХАНІЗМИ

UDC 621.867.21

V. M. BOHOMAZ^{1*}

^{1*}Dep. «Military training of specialists of the State special service of transport», Dnipropetrovsk National University of Railway Transport named after Academician V. Lazaryan, Lazaryan St., 2, Dnipropetrovsk, Ukraine, 49010, tel. +38 (056) 793 19 09, e-mail wbogomas@i.ua, ORCID 0000-0001-5913-2671

RESEARCH OF DEPENDENCE OF BELT CONVEYER DRIVE POWER ON ITS DESIGN PARAMETERS

Purpose. A drive is one of the basic elements of belt conveyers. To determine the drive power it is necessary to conduct calculations by standard methodologies expounded in modern technical literature. Such calculations demand a fair amount of time. The basic design parameters of a belt conveyer include type of load, design efficiency, geometrical dimensions and path configuration, operation conditions. The article aims to build the parametric dependence of belt conveyer drive power on its design parameters, that takes into account standard dimensions and parameters of belts, idlers and pulleys. **Methodology.** The work examines a belt conveyer with two areas: sloping and horizontal. Using the methodology for pulling calculation by means of belt conveyer encirclement, there are built parametric dependences of pull forces in the characteristic conveyer path points on the type of load, design efficiency, geometrical dimensions and path configuration, operation conditions. **Findings.** For the belt conveyers of the considered type there are built parametric dependences of drive power on type of load, design efficiency, geometrical dimensions and path configuration, operation conditions, taking into account the belt standard dimensions and corresponding assumptions in relation to idler and pulley types. **Originality.** This is the first developed parametric dependence of two-area (sloping and horizontal) belt conveyer drive power on type of load, design efficiency, geometrical dimensions and path configuration, operation conditions that takes into account standard dimensions and parameters of belts, idlers and pulleys. **Practical value.** Use of the built drive power dependences on design parameters for the belt conveyers with sloping and horizontal areas gives an opportunity of relatively rapid determination of drive power approximate value at the design stage. Also it allows quality selection of its basic elements at specific design characteristics and requirements. The offered dependences can be used for determination of general character of drive power dependence on the project efficiency.

Keywords: conveyer; belt; drive; power; efficiency; load

Introduction

Transporting machines are important elements of transport and industrial construction sector. Continuous-transport machines are the foundation of the comprehensive mechanization of cargo handling, industrial processes, they increase productivity and efficiency. The most common type of continuous transport is belt conveyers. Belt conveyers are the continuous-type machines, the main ele-

ment of which is vertically closed rubber belt that encircles the end pulleys, one of which is usually the drive one, the other – the idler one. Belt conveyers are widely used in the chemical, metallurgical, machine-building industry, for production of building materials, transport and industrial construction, at the coal preparation plants.

The main publications that describe the structure, design features, operational and design parameters of the conveyers are [4, 5, 6, 7, 8, 9, 10].

НЕТРАДИЦІЙНІ ВИДИ ТРАНСПОРТУ. МАШИНИ ТА МЕХАНІЗМИ

The analysis of publications shows that for determining the conveyor drive parameters, particularly its power, it is necessary to conduct calculation for its pulleys, pulling element (belt), pulling calculation and to select the basic drive elements. The procedure of these calculations is described in detail in [7, 8]. But the use of traditional conveyor drive calculation methods takes some time. Today, the constant development of almost all industries demands more rapid decision-making in the design of continuous-transport machines, which are elements of the production lines. Therefore, to improve the belt conveyor drive design process it is desirable to determine a scheme that allows using the more simple and quick calculations to determine the necessary value of the drive power depending on the design parameters. Such a scheme is proposed for elevators in [2, 3].

Purpose

The work aims to build the parametric dependence for drive power of the belt conveyor with sloping and horizontal areas on type of load, design efficiency, geometrical dimensions and path configuration, operation conditions.

Methodology

The value of belt conveyor drive power depends on many factors. The main parameters affecting its value are: type of load, design efficiency, load lifting height and conveying distance, required load transportation path configuration, conveyor operation conditions. The design diagram

of the conveyor under study and its approximate belt tension chart are shown in Figure 1.

Initial data for design calculations of the examined belt conveyor are as follows:

- Transported material;
- Conveyor efficiency;
- Height or angle of the conveyor sloping area, H or β respectively;
- Lengths of conveyor sections and radius: L_{12} , L_{34} , L_{56} , L_{r56} , L_{67} , L_{78} , R_1 m.

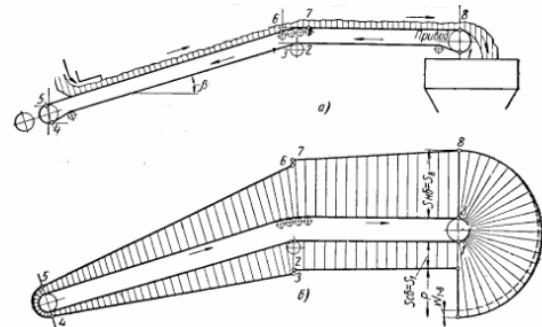

Fig. 1. Belt conveyor: a – design diagram; b – belt tension chart

For further study we determine that the conveyor has grooved three-roller idlers with 20° angle on the loaded belt and row straight idlers – on the return belt.

Taking into account the data of the tables 8.1 and 8.2 of [8] we present in Table 1 the basic properties of the load that are needed for further calculations:

Table 1

Belt speed and load properties

Bulk load	material density ρ , t/m ³	coefficient k_{cs}	Belt speed, m/s, at the width, mm				
			400	500 and 650	800...1 200	1 200... 1 600	1 800... 2 000
sand	1.4 – 1.65	470	1.3	1.5	2.6	3.3	5.5
peat	0.33 – 0.4	550	1.3	1.5	2.6	3.3	5.5
soil	1.1 – 1.6	470	1.3	1.5	2.6	3.3	5.5
gravel	1.5 – 1.9	470	1.1	1.3	1.8	2.6	3.6
stones	1.8 – 2.2	550	–	1.3	1.3	1.8	2.6
coal	0.8 – 1.0	470	1.1	1.3	1.4	1.8	–
cement	1.0 – 1.8	470	–	1.1	1.0	–	–
crushed stone	1.3 – 1.8	550	1.1	1.3	1.8	2.6	3.6

НЕТРАДИЦІЙНІ ВИДИ ТРАНСПОРТУ. МАШИНИ ТА МЕХАНІЗМИ

The belt speed values in Table 1 are counted as the mean in a given range of possible values for the set load.

The belt width required for the set efficiency E is calculated by the formula

$$B_e \geq 1,1 \left(\sqrt{\frac{E}{k_{cs} k_{\beta} \rho v}} + 0,05 \right), \quad (1)$$

where k_{cs} – cross-section coefficient of the material on belt (Table 1); k_{β} – coefficient for cross-section decrease of the material on belt due to its partial bulking into the side opposite to the travel direction (p. 403, [8]); ρ – bulk density of transported material (Table 1), t/m^3 .

The determined belt width value is rounded up to the nearest biggest number of a standard row of belt width: 400; 500; 650; 800; 1 000, 1 200 mm.

For convenience of further research, we will do some algebraic transformation in the expression (1). The result is as follows:

$$k_{cs} \rho v (0,91 B_e - 0,05)^2 \geq \frac{E}{k_{\beta}}. \quad (2)$$

For unambiguous determination of the required width to achieve the conveyor design efficiency the ratio E/k_{β} must appertain to some range of values. These ranges are shown in Table 2. The value E/k_{β} depends on the belt width, type of load and accepted load material density. The limit values of the ranges in Table 2 are calculated for the corresponding limit values of material density. For example, for sand and belt width $B = 400$ mm the range of variation is $E/k_{\beta} = 84.3 - 99.4$, herewith 84.3 corresponds to the sand density $1.4 t/m^3$ and 99.4 – to the sand density $1.65 t/m^3$.

Example of usage of Table 1: let the load be soil with the density $\rho = 1.6 t/m^3$, the angle $\beta = 22^\circ$ and the required efficiency $E = 64 t/h$. With the help of (p. 403 [8]) we get: $k_{\beta} = 0.76$. We calculate the ratio $E/k_{\beta} = 64/0.76 = 84.2 < 99.4$, thus, this value corresponds to the width of the belt $B = 400$ mm. This width is taken for further calculations.

It should also be noted that the inequality sign must be considered in the ratio (2) as follows: the

soil density $\rho = 1.6 t/m^3$ and belt width $B = 400$ mm go with the range of values E/k_{β} [0...96.4], $B = 500$ mm – the range E/k_{β} [96.4...185], $B = 650$ mm – the range E/k_{β} [185...330.7], $B = 800$ mm – the range E/k_{β} [330.7...898.8], $B = 1 000$ mm – the range E/k_{β} [898.8...1 446.1], $B = 1 200$ mm – the range E/k_{β} [1446.1...2 694.4]. Accordingly, the soil density $\rho = 1.1 t/m^3$ and belt width $B = 400$ mm go with the range of values E/k_{β} [0...66.3], $B = 500$ mm – the range E/k_{β} [66.3...127.2], $B = 650$ mm – the range E/k_{β} [127.2...227.4], $B = 800$ mm – the range E/k_{β} [227.4...617.9], $B = 1000$ mm – the range E/k_{β} [617.9...994.2], $B = 1200$ mm – the range E/k_{β} [994.2...1852.4]

For further calculation the conveyor pulling element circuit is divided into straight and curved sections (see Fig. 1a). To determine the belt tension we use the method of pulling calculation by circuit.

We adopt the conveyor drive with one driving pulley, the wrap angle of which is $\gamma = 180^\circ$. The pulley surface is lined with rubber.

The efforts in the belt entering the drive pulley are determined by Euler's formula:

$$S_{eb} = S_8 \leq S_1 e^{\mu \gamma}, \quad (3)$$

where μ – friction factor between the belt and the pulley surface; γ – belt wrap angle of drive pulley, radian; $e^{\mu \gamma}$ – pulling factor (Table 3).

There are two unknown terms S_1 and S_8 in the equation (3). To formulate the second equation it is necessary to encircle the pulling circuit from point 1 to point 8, expressing the tension at all points through the tension at point 1. The specific weight of the material on belt is determined by the formula

$$q_m = \frac{Eg}{3.6v} = \beta E, \quad (4)$$

where $\beta = \frac{g}{3.6v}$ – coefficient that depends on the belt speed, $N \cdot s/kg \cdot m$.

НЕТРАДИЦІЙНІ ВИДИ ТРАНСПОРТУ. МАШИНИ ТА МЕХАНІЗМИ

The specific weight of moving parts of upper and lower idlers is determined by formulas:

$$q_{ui} = G_i' / l_i' ; \quad (5)$$

$$q_{li} = G_i'' / l_i'' , \quad (6)$$

where G_i' , G_i'' – weight of rotating parts of upper and lower idlers respectively.

The spacing of upper and lower idlers l_i on the path is taken according to the table 8.3 [8]. The lower row idlers are arranged with the double l_i spacing.

Using the data from tables 8.3 – 8.5 [8] and the formulas (5) – (6) we calculate the specific weight of moving parts of upper and lower idlers. The following table shows the values of the specific weight of moving parts of upper and lower idlers depending on the belt width and load density.

Using the data in table 1 and the formula (4), we built dependence of the loaded material specific weight on the belt width and the conveyor efficiency. The resulted data are shown in Table 5.

Table 2

Ranges of ratio values E/k_B corresponding to type of load and belt width

Bulk load	material density ρ , t/m ³	Ranges of ratio values E/k_B , t/h, with the belt width, mm					
		400	500	650	800	1 000	1 200
sand	1.4 – 1.65	84,3-99,4	161,9-190,8	289,4-341,1	786,5-926,9	1265,3-1491,3	2357,6-2778,6
peat	0.33 – 0.4	23.3-28.2	44.6-54.1	79.8-96.7	216.9-262.9	349-423	650.3-788.3
soil	1.1 – 1.6	66.3-96.4	127.2-185	227.4-330.7	617.9-898.8	994.2-1446.1	1852.4-2694.4
grave l	1.5 – 1.9	76.5-96.9	150.3-190.4	268.7-340.4	583.3-738.9	938.5-1188.8	1990.2-2520.9
stone s	1.8 – 2.2	–	211.1-258	377.3-461.2	591.6-723.1	951.9-1163.4	1934.8-2364.8
coal	0.8 – 1.0	40.8-51	80.2-100.2	143.3-179.1	242-302.5	389.4-486.7	734.88-918.6
ce-ment	1.0 – 1.8	–	84.8-152.6	151.6-272.8	216.1-388.9	347.6-625.7	–
crush ed stone	1.3 – 1.8	77.6-107.4	152.5-211.1	272.6-377.4	591.6-819.2	951.9-1318	2018.5-2794.8

Table 3

Value of pulling factor $e^{\mu\gamma}$

μ	γ , grad (radian)				
	180 (3.14)	190 (3.22)	200 (3.50)	210 (3.67)	240 (4.19)
0.2 (without lining)	1.88	1.94	2.01	2.08	2.31
0.3 (with wood lining)	2.57	2.71	2.85	3.01	3.52
0.4 (with rubber lining)	3.52	3.78	4.05	4.34	5.35

Table 4

Specific weight of moving parts of upper and lower idlers

Belt width, mm	q_{ui} at load density ρ , N/m			q_{li} at load density ρ , N/m		
	up to 1 t/m ³	1...2 t/m ³	above 2 t/m ³	up to 1 t/m ³	1...2 t/m ³	above 2 t/m ³
400	66.7	71.4	76.9	20	21.5	23.1
500	76.7	82.1	88.5	25	26.8	28.9
650	89.3	96.2	104.2	37.5	40.4	43.8
800	157.1	169.2	183.3	61.1	71.2	77.1
1 000	192.3	208.3	227.3	84.6	91.7	100
1 200	223.1	241.7	263.6	96.2	104.2	113.7

Table 5

Dependence of loaded material specific weight q_m on belt width and conveyor efficiency

Bulk load	Belt width, mm				
	400	500 та 650	800...1200	1200...21600	1800...2000
sand	2.14E	1.85E	1.07E	0.84E	0.51E
peat	2.14E	1.85E	1.07E	0.84E	0.51E
soil	2.14E	1.85E	1.07E	0.84E	0.51E
gravel	2.53E	2.14E	1.54E	1.07E	0.77E
stones	–	2.14E	2.14E	1.54E	1.07E
coal	2.53E	2.14E	1.98E	1.54E	–
cement	–	2.53E	2.78E	–	–
crushed stone	2.53E	2.14E	1.54E	1.07E	0.77E

For clarity in subsequent calculations we adopt as a working element the conveyor fabric-ply belt by GOST 20-85 BKNL-150, whose gasket tensile strength $S_p = 150$ N/mm. In addition, further on we will assume that the conveyor operation conditions are heavy or very heavy.

The belt thickness is determined by the formula

$$\delta_b = \delta_o + i\delta_g + \delta_n, \quad (7)$$

where δ_o , δ_n – thickness of rubber gaskets from operating and non- operating belt sides; δ_g – thickness of one fabric gasket; $\delta_g = 1.6$ mm for BKNL-150-type belts.

The gasket thickness is selected subject to heavy operation conditions of the conveyor, so $\delta_o = 6$ mm, $\delta_n = 2$ mm, while

$$\delta_b = 6 + i \cdot 1.6 + 2 = 8 + i \cdot 1.6 \text{ mm.}$$

The belt running meter weight is calculated by the formula

$$q_b = 0.01B\delta_b, \quad (8)$$

where B and δ_b should be substituted in millimetres.

Using the formulas (7) – (8) we obtained the dependence of the belt linear weight value on the number of gaskets and the belt width (Table 6).

The basic principle of the encirclement method is to identify the specific points of the path, where there are changes of belt tension. Herewith the tension in the following $(i+1)$ point equals the sum of the belt tension in this (i) point and the belt transport resistance at the section between these points:

НЕТРАДИЦІЙНІ ВИДИ ТРАНСПОРТУ. МАШИНИ ТА МЕХАНІЗМИ

$$S_{i+1} = S_i + W_{i,i+1}. \quad (9)$$

Belt tension at point 2 is calculated by the formula

$$S_2 = S_1 + W_{12}, \quad (10)$$

where W_{12} – belt transport resistance at the section between the points 1 and 2;

$$W_{12} = wL_r (q_b + q_{li}). \quad (11)$$

where w – belt transport resistance (Table 7), which depends on the type of bearing, lubrication, sealing, dustiness of atmosphere and other conditions.

For further research it is assumed that $w = 0.03$ (operation conditions are heavy, lower idlers are straight, upper idlers are grooved). Using the tables 5 and 6, we obtained the expressions for tension force values at point 2, depending on the belt width and load density (Table 8).

Belt tension at point 3 is calculated by the formula

$$S_3 = k S_2, \quad (12)$$

where k – coefficient for increase in belt tension due to idler pulley rotating resistance (Table 9).

Table 6

Belt linear weight

Belt width B , mm	Belt linear weight at $i = 3$, N/m	Belt linear weight at $i = 4$, N/m	Belt linear weight at $i = 5$, N/m	Belt linear weight at $i = 6$, N/m
400	51.2	57.6	64	70.4
500	64	72	80	88
650	83.2	93.6	104	114.4
800	102.4	115.2	128	140.8
1 000	128	144	160	176
1 200	153.6	172.8	192	211.2

Table 7

Value of coefficient w

Conveyor operation conditions	Idlers	
	straight	grooved
Light	0.018	0.020
Average	0.022	0.025
Heavy, very heavy	0.030	0.030

Table 8

Belt tension at point 2

Belt width, mm	S_2 at load density ρ , N/m		
	up to 1 t/m ³	1...2 t/m ³	above 2 t/m ³
400	$S_1 + 0.03L_1(q_b + 20)$	$S_1 + 0.03L_1(q_b + 21.5)$	$S_1 + 0.03L_1(q_b + 23.1)$
500	$S_1 + 0.03L_1(q_b + 25)$	$S_1 + 0.03L_1(q_b + 26.8)$	$S_1 + 0.03L_1(q_b + 28.9)$
650	$S_1 + 0.03L_1(q_b + 37.5)$	$S_1 + 0.03L_1(q_b + 40.4)$	$S_1 + 0.03L_1(q_b + 43.8)$
800	$S_1 + 0.03L_1(q_b + 61.1)$	$S_1 + 0.03L_1(q_b + 71.2)$	$S_1 + 0.03L_1(q_b + 77.1)$
1 000	$S_1 + 0.03L_1(q_b + 84.6)$	$S_1 + 0.03L_1(q_b + 91.7)$	$S_1 + 0.03L_1(q_b + 100)$
1 200	$S_1 + 0.03L_1(q_b + 96.2)$	$S_1 + 0.03L_1(q_b + 104.2)$	$S_1 + 0.03L_1(q_b + 113.7)$

НЕТРАДИЦІЙНІ ВИДИ ТРАНСПОРТУ. МАШИНИ ТА МЕХАНІЗМИ

In the considered conveyor design the belt wrap angle of pulley is less than 90° (Fig. 1), thus $k=1.03$.

Table 9

Value of coefficient k	
Belt wrap angle of pulley, degrees	k
<90	1.03
90	1.04
180	1.05

Dependencies to determine the tension force value at point 3 by belt width and load density are shown in Table 10.

Belt tension at point 4 is calculated by the formula

$$S_4 = S_3 + W_{34}, \quad (13)$$

where W_{34} – belt transport resistance at the section between the points 3 and 4;

$$W_{34} = q_b L_{34} (w \cdot \cos \beta - \sin \beta) + q_{li} L_{34} w, \quad (14)$$

where w – belt transport resistance coefficient (Table 7).

If $w=0.03$ (operation conditions are heavy, lower idlers are straight), then the dependences for tension force values at point 4 by belt width and load density are shown in Table 11.

Belt tension at point 5 is calculated by the formula

$$S_5 = k S_4, \quad (15)$$

where k – coefficient for increase in belt tension due to idler pulley rotating resistance (Table 9).

In the considered conveyor design the belt wrap angle of pulley is 180° (Fig. 1), therefore, we assume that $k=1.05$.

Dependencies for tension force values at point 5 by belt width and load density are shown in Table 12.

Belt tension at point 6 is calculated by the formula

$$S_6 = S_5 + W_{56}, \quad (16)$$

where W_{56} – belt transport resistance at the section between the points 5 and 6;

$$W_{56} = (q_m + q_b) L_{56} (w \cdot \cos \beta + \sin \beta) + q_{ui} L_{56} w, \quad (17)$$

where w – belt transport resistance coefficient (Table 7).

If $w=0.03$ (operation conditions are heavy, upper idlers are grooved), then the dependences for tension force values at point 6 by belt width and load density are shown in Table 13.

Belt tension at point 7 is calculated by Euler's formula:

$$S_7 = S_6 e^{w\alpha}, \quad (18)$$

where w – friction factor between the belt and the idler surface; α – belt wrap angle of battery of idlers, radian.

Belt wrap angle of battery of idlers:

$$\alpha = \frac{L_{67}}{R_1}. \quad (19)$$

Dependencies for tension force values at point 7 by belt width and load density are shown in Table 14.

Table 10

Belt tension at point 3

Belt width, mm	S_3 at load density ρ , N/m		
	up to 1 t/m ³	1...2 t/m ³	above 2 t/m ³
400	1.03 $S_1 + 0.031L_1(q_b + 20)$	1.03 $S_1 + 0.031L_1(q_b + 21.5)$	1.03 $S_1 + 0.031L_1(q_b + 23.1)$
500	1.03 $S_1 + 0.031L_1(q_b + 25)$	1.03 $S_1 + 0.031L_1(q_b + 26.8)$	1.03 $S_1 + 0.031L_1(q_b + 28.9)$
650	1.03 $S_1 + 0.031L_1(q_b + 37.5)$	1.03 $S_1 + 0.031L_1(q_b + 40.4)$	1.03 $S_1 + 0.031L_1(q_b + 43.8)$
800	1.03 $S_1 + 0.031L_1(q_b + 61.1)$	1.03 $S_1 + 0.031L_1(q_b + 71.2)$	1.03 $S_1 + 0.031L_1(q_b + 77.1)$
1 000	1.03 $S_1 + 0.031L_1(q_b + 84.6)$	1.03 $S_1 + 0.031L_1(q_b + 91.7)$	1.03 $S_1 + 0.031L_1(q_b + 100)$
1 200	1.03 $S_1 + 0.031L_1(q_b + 96.2)$	1.03 $S_1 + 0.031L_1(q_b + 104.2)$	1.03 $S_1 + 0.031L_1(q_b + 113.7)$

Table 11

Belt tension at point 4

Belt width, mm	S_4 at load density ρ , N/m		
	up to 1 t/m ³	1...2 t/m ³	above 2 t/m ³
400	$1.03S_1+0.031 q_b(L_1+L_{34}\cos\beta-32.3L_{34}\sin\beta)+0.62(L_1+L_{34})$	$1.03S_1+0.031 q_b(L_1+L_{34}\cos\beta-32.3L_{34}\sin\beta)+0.66(L_1+L_{34})$	$1.03S_1+0.031 q_b(L_1+L_{34}\cos\beta-32.3L_{34}\sin\beta)+0.72(L_1+L_{34})$
500	$1.03S_1+0.031 q_b(L_1+L_{34}\cos\beta-32.3L_{34}\sin\beta)+0.77(L_1+L_{34})$	$1.03S_1+0.031 q_b(L_1+L_{34}\cos\beta-32.3L_{34}\sin\beta)+0.83(L_1+L_{34})$	$1.03S_1+0.031 q_b(L_1+L_{34}\cos\beta-32.3L_{34}\sin\beta)+0.9(L_1+L_{34})$
650	$1.03S_1+0.031 q_b(L_1+L_{34}\cos\beta-32.3L_{34}\sin\beta)+1.16(L_1+L_{34})$	$1.03S_1+0.031 q_b(L_1+L_{34}\cos\beta-32.3L_{34}\sin\beta)+1.25(L_1+L_{34})$	$1.03S_1+0.031 q_b(L_1+L_{34}\cos\beta-32.3L_{34}\sin\beta)+1.35(L_1+L_{34})$
800	$1.03S_1+0.031 q_b(L_1+L_{34}\cos\beta-32.3L_{34}\sin\beta)+2.1(L_1+L_{34})$	$1.03S_1+0.031 q_b(L_1+L_{34}\cos\beta-32.3L_{34}\sin\beta)+2.2(L_1+L_{34})$	$1.03S_1+0.031 q_b(L_1+L_{34}\cos\beta-32.3L_{34}\sin\beta)+2.39(L_1+L_{34})$
1 000	$1.03S_1+0.031 q_b(L_1+L_{34}\cos\beta-32.3L_{34}\sin\beta)+2.6(L_1+L_{34})$	$1.03S_1+0.031 q_b(L_1+L_{34}\cos\beta-32.3L_{34}\sin\beta)+2.84(L_1+L_{34})$	$1.03S_1+0.031 q_b(L_1+L_{34}\cos\beta-32.3L_{34}\sin\beta)+3.1(L_1+L_{34})$
1 200	$1.03S_1+0.031 q_b(L_1+L_{34}\cos\beta-32.3L_{34}\sin\beta)+2.98(L_1+L_{34})$	$1.03S_1+0.031 q_b(L_1+L_{34}\cos\beta-32.3L_{34}\sin\beta)+3.23(L_1+L_{34})$	$1.03S_1+0.031 q_b(L_1+L_{34}\cos\beta-32.3L_{34}\sin\beta)+3.5(L_1+L_{34})$

Table 12

Belt tension at point 5

Belt width, mm	S_5 at load density ρ , N/m		
	up to 1 t/m ³	1...2 t/m ³	above 2 t/m ³
400	$1.08S_1+0.033 q_b(L_1+L_{34}\cos\beta-32.3L_{34}\sin\beta)+0.65(L_1+L_{34})$	$1.08S_1+0.033 q_b(L_1+L_{34}\cos\beta-32.3L_{34}\sin\beta)+0.7(L_1+L_{34})$	$1.08S_1+0.033 q_b(L_1+L_{34}\cos\beta-32.3L_{34}\sin\beta)+0.75(L_1+L_{34})$
500	$1.08S_1+0.033 q_b(L_1+L_{34}\cos\beta-32.3L_{34}\sin\beta)+0.81(L_1+L_{34})$	$1.08S_1+0.033 q_b(L_1+L_{34}\cos\beta-32.3L_{34}\sin\beta)+0.87(L_1+L_{34})$	$1.08S_1+0.033 q_b(L_1+L_{34}\cos\beta-32.3L_{34}\sin\beta)+0.94(L_1+L_{34})$
650	$1.08S_1+0.033 q_b(L_1+L_{34}\cos\beta-32.3L_{34}\sin\beta)+1.23(L_1+L_{34})$	$1.08S_1+0.033 q_b(L_1+L_{34}\cos\beta-32.3L_{34}\sin\beta)+1.31(L_1+L_{34})$	$1.08S_1+0.033 q_b(L_1+L_{34}\cos\beta-32.3L_{34}\sin\beta)+1.42(L_1+L_{34})$
800	$1.08S_1+0.033 q_b(L_1+L_{34}\cos\beta-32.3L_{34}\sin\beta)+2.15(L_1+L_{34})$	$1.08S_1+0.033 q_b(L_1+L_{34}\cos\beta-32.3L_{34}\sin\beta)+2.31(L_1+L_{34})$	$1.08S_1+0.033 q_b(L_1+L_{34}\cos\beta-32.3L_{34}\sin\beta)+2.5(L_1+L_{34})$

НЕТРАДИЦІЙНІ ВИДИ ТРАНСПОРТУ. МАШИНИ ТА МЕХАНІЗМИ

End of table 12

Belt width, mm	S_5 at load density ρ , N/m		
	up to 1 t/m ³	1...2 t/m ³	above 2 t/m ³
1 000	$1.08S_1+0.033 q_b(L_1+L_{34}\cos\beta-32.3L_{34}\sin\beta)+2.75(L_1+L_{34})$	$1.08S_1+0.033 q_b(L_1+L_{34}\cos\beta-32.3L_{34}\sin\beta)+2.98(L_1+L_{34})$	$1.08S_1+0.033 q_b(L_1+L_{34}\cos\beta-32.3L_{34}\sin\beta)+3.25(L_1+L_{34})$
1 200	$1.08S_1+0.033 q_b(L_1+L_{34}\cos\beta-32.3L_{34}\sin\beta)+3.13(L_1+L_{34})$	$1.08S_1+0.033 q_b(L_1+L_{34}\cos\beta-32.3L_{34}\sin\beta)+3.39(L_1+L_{34})$	$1.08S_1+0.033 q_b(L_1+L_{34}\cos\beta-32.3L_{34}\sin\beta)+3.7(L_1+L_{34})$

Table 13

Belt tension at point 6

Belt width, mm	S_6 at load density ρ , N/m		
	up to 1 t/m ³	1...2 t/m ³	above 2 t/m ³
400	$1.08S_1+0.033 q_b(L_1+(L_{34}+L_{56})\cos\beta+32.3(L_{56}-L_{34})\sin\beta)+0.65(L_1+L_{34}+3.08 L_{56})+q_m L_{56} (0.03\cos\beta+\sin\beta)$	$1.08S_1+0.033 q_b(L_1+(L_{34}+L_{56})\cos\beta+32.3(L_{56}-L_{34})\sin\beta)+0.7(L_1+L_{34}+3.06 L_{56})+q_m L_{56} (0.03\cos\beta+\sin\beta)$	$1.08S_1+0.033 q_b(L_1+(L_{34}+L_{56})\cos\beta+32.3(L_{56}-L_{34})\sin\beta)+0.75(L_1+L_{34}+3.08 L_{56})+q_m L_{56} (0.03\cos\beta+\sin\beta)$
500	$1.08S_1+0.033 q_b(L_1+(L_{34}+L_{56})\cos\beta+32.3(L_{56}-L_{34})\sin\beta)+0.81(L_1+L_{34}+2.82 L_{56})+q_m L_{56} (0.03\cos\beta+\sin\beta)$	$1.08S_1+0.033 q_b(L_1+(L_{34}+L_{56})\cos\beta+32.3(L_{56}-L_{34})\sin\beta)+0.87(L_1+L_{34}+2.84 L_{56})+q_m L_{56} (0.03\cos\beta+\sin\beta)$	$1.08S_1+0.033 q_b(L_1+(L_{34}+L_{56})\cos\beta+32.3(L_{56}-L_{34})\sin\beta)+0.94(L_1+L_{34}+2.82 L_{56})+q_m L_{56} (0.03\cos\beta+\sin\beta)$
650	$1.08S_1+0.033 q_b(L_1+(L_{34}+L_{56})\cos\beta+32.3(L_{56}-L_{34})\sin\beta)+1.23(L_1+L_{34}+2.18 L_{56})+q_m L_{56} (0.03\cos\beta+\sin\beta)$	$1.08S_1+0.033 q_b(L_1+(L_{34}+L_{56})\cos\beta+32.3(L_{56}-L_{34})\sin\beta)+1.41(L_1+L_{34}+2.2 L_{56})+q_m L_{56} (0.03\cos\beta+\sin\beta)$	$1.08S_1+0.033 q_b(L_1+(L_{34}+L_{56})\cos\beta+32.3(L_{56}-L_{34})\sin\beta)+1.43(L_1+L_{34}+2.2 L_{56})+q_m L_{56} (0.03\cos\beta+\sin\beta)$
800	$1.08S_1+0.033 q_b(L_1+(L_{34}+L_{56})\cos\beta+32.3(L_{56}-L_{34})\sin\beta)+2.15(L_1+L_{34}+2.2 L_{56})+q_m L_{56} (0.03\cos\beta+\sin\beta)$	$1.08S_1+0.033 q_b(L_1+(L_{34}+L_{56})\cos\beta+32.3(L_{56}-L_{34})\sin\beta)+2.31(L_1+L_{34}+2.2 L_{56})+q_m L_{56} (0.03\cos\beta+\sin\beta)$	$1.08S_1+0.033 q_b(L_1+(L_{34}+L_{56})\cos\beta+32.3(L_{56}-L_{34})\sin\beta)+2.5(L_1+L_{34}+2.2 L_{56})+q_m L_{56} (0.03\cos\beta+\sin\beta)$
1 000	$1.08S_1+0.033 q_b(L_1+(L_{34}+L_{56})\cos\beta+32.3(L_{56}-L_{34})\sin\beta)+2.75(L_1+L_{34}+2.1 L_{56})+q_m L_{56} (0.03\cos\beta+\sin\beta)$	$1.08S_1+0.033 q_b(L_1+(L_{34}+L_{56})\cos\beta+32.3(L_{56}-L_{34})\sin\beta)+2.98(L_1+L_{34}+2.1 L_{56})+q_m L_{56} (0.03\cos\beta+\sin\beta)$	$1.08S_1+0.033 q_b(L_1+(L_{34}+L_{56})\cos\beta+32.3(L_{56}-L_{34})\sin\beta)+3.25(L_1+L_{34}+2.1 L_{56})+q_m L_{56} (0.03\cos\beta+\sin\beta)$
1 200	$1.08S_1+0.033 q_b(L_1+(L_{34}+L_{56})\cos\beta+32.3(L_{56}-L_{34})\sin\beta)+3.13(L_1+L_{34}+2.14 L_{56})+q_m L_{56} (0.03\cos\beta+\sin\beta)$	$1.08S_1+0.033 q_b(L_1+(L_{34}+L_{56})\cos\beta+32.3(L_{56}-L_{34})\sin\beta)+3.39(L_1+L_{34}+2.14 L_{56})+q_m L_{56} (0.03\cos\beta+\sin\beta)$	$1.08S_1+0.033 q_b(L_1+(L_{34}+L_{56})\cos\beta+32.3(L_{56}-L_{34})\sin\beta)+3.7(L_1+L_{34}+2.14 L_{56})+q_m L_{56} (0.03\cos\beta+\sin\beta)$

Table 14

Belt tension at point 7

Belt width, mm	S_7 at load density ρ , N/m		
	up to 1 t/m ³	1...2 t/m ³	above 2 t/m ³
400	$e^{w\alpha} [1.08S_1+0.033 q_b(L_1+(L_{34}+L_{56})\cos\beta+32.3(L_{56}-L_{34})\sin\beta)+0.65(L_1+L_{34}+3.08 L_{56})+q_m L_{56} (0.03\cos\beta+\sin\beta)]$	$e^{w\alpha} [1.08S_1+0.033 q_b(L_1+(L_{34}+L_{56})\cos\beta+32.3(L_{56}-L_{34})\sin\beta)+0.7(L_1+L_{34}+3.06 L_{56})+q_m L_{56} (0.03\cos\beta+\sin\beta)]$	$e^{w\alpha} [1.08S_1+0.033 q_b(L_1+(L_{34}+L_{56})\cos\beta+32.3(L_{56}-L_{34})\sin\beta)+0.75(L_1+L_{34}+3.08 L_{56})+q_m L_{56} (0.03\cos\beta+\sin\beta)]$
500	$e^{w\alpha} [1.08S_1+0.033 q_b(L_1+(L_{34}+L_{56})\cos\beta+32.3(L_{56}-L_{34})\sin\beta)+0.81(L_1+L_{34}+2.82 L_{56})+q_m L_{56} (0.03\cos\beta+\sin\beta)]$	$e^{w\alpha} [1.08S_1+0.033 q_b(L_1+(L_{34}+L_{56})\cos\beta+32.3(L_{56}-L_{34})\sin\beta)+0.87(L_1+L_{34}+2.84 L_{56})+q_m L_{56} (0.03\cos\beta+\sin\beta)]$	$e^{w\alpha} [1.08S_1+0.033 q_b(L_1+(L_{34}+L_{56})\cos\beta+32.3(L_{56}-L_{34})\sin\beta)+0.94(L_1+L_{34}+2.82 L_{56})+q_m L_{56} (0.03\cos\beta+\sin\beta)]$
650	$e^{w\alpha} [1.08S_1+0.033 q_b(L_1+(L_{34}+L_{56})\cos\beta+32.3(L_{56}-L_{34})\sin\beta)+1.23(L_1+L_{34}+2.18 L_{56})+q_m L_{56} (0.03\cos\beta+\sin\beta)]$	$e^{w\alpha} [1.08S_1+0.033 q_b(L_1+(L_{34}+L_{56})\cos\beta+32.3(L_{56}-L_{34})\sin\beta)+1.41(L_1+L_{34}+2.2 L_{56})+q_m L_{56} (0.03\cos\beta+\sin\beta)]$	$e^{w\alpha} [1.08S_1+0.033 q_b(L_1+(L_{34}+L_{56})\cos\beta+32.3(L_{56}-L_{34})\sin\beta)+1.43(L_1+L_{34}+2.2 L_{56})+q_m L_{56} (0.03\cos\beta+\sin\beta)]$
800	$e^{w\alpha} [1.08S_1+0.033 q_b(L_1+(L_{34}+L_{56})\cos\beta+32.3(L_{56}-L_{34})\sin\beta)+2.15(L_1+L_{34}+2.2 L_{56})+q_m L_{56} (0.03\cos\beta+\sin\beta)]$	$e^{w\alpha} [1.08S_1+0.033 q_b(L_1+(L_{34}+L_{56})\cos\beta+32.3(L_{56}-L_{34})\sin\beta)+2.31(L_1+L_{34}+2.2 L_{56})+q_m L_{56} (0.03\cos\beta+\sin\beta)]$	$e^{w\alpha} [1.08S_1+0.033 q_b(L_1+(L_{34}+L_{56})\cos\beta+32.3(L_{56}-L_{34})\sin\beta)+2.5(L_1+L_{34}+2.2 L_{56})+q_m L_{56} (0.03\cos\beta+\sin\beta)]$
1 000	$e^{w\alpha} [1.08S_1+0.033 q_b(L_1+(L_{34}+L_{56})\cos\beta+32.3(L_{56}-L_{34})\sin\beta)+2.75(L_1+L_{34}+2.1 L_{56})+q_m L_{56} (0.03\cos\beta+\sin\beta)]$	$e^{w\alpha} [1.08S_1+0.033 q_b(L_1+(L_{34}+L_{56})\cos\beta+32.3(L_{56}-L_{34})\sin\beta)+2.98(L_1+L_{34}+2.1 L_{56})+q_m L_{56} (0.03\cos\beta+\sin\beta)]$	$e^{w\alpha} [1.08S_1+0.033 q_b(L_1+(L_{34}+L_{56})\cos\beta+32.3(L_{56}-L_{34})\sin\beta)+3.25(L_1+L_{34}+2.1 L_{56})+q_m L_{56} (0.03\cos\beta+\sin\beta)]$
1 200	$e^{w\alpha} [1.08S_1+0.033 q_b(L_1+(L_{34}+L_{56})\cos\beta+32.3(L_{56}-L_{34})\sin\beta)+3.13(L_1+L_{34}+2.14 L_{56})+q_m L_{56} (0.03\cos\beta+\sin\beta)]$	$e^{w\alpha} [1.08S_1+0.033 q_b(L_1+(L_{34}+L_{56})\cos\beta+32.3(L_{56}-L_{34})\sin\beta)+3.39(L_1+L_{34}+2.14 L_{56})+q_m L_{56} (0.03\cos\beta+\sin\beta)]$	$e^{w\alpha} [1.08S_1+0.033 q_b(L_1+(L_{34}+L_{56})\cos\beta+32.3(L_{56}-L_{34})\sin\beta)+3.7(L_1+L_{34}+2.14 L_{56})+q_m L_{56} (0.03\cos\beta+\sin\beta)]$

Belt tension at point 8 is calculated by the formula

$$S_8 = S_7 + W_{78}, \quad (20)$$

where W_{78} – belt transport resistance at the section between the points 7 and 8;

$$W_{78} = (q_m + q_b + q_{ui}) L_{78} w, \quad (21)$$

where w – belt transport resistance coefficient (Table 7).

If $w = 0.03$ (operation conditions are heavy, upper idlers are grooved), then the dependences for tension force values at point 8 by belt width and load density are shown in Table 15.

Table 15

Belt tension at point 8

Belt width, mm	S_8 at load density ρ , N/m		
	up to 1 t/m ³	1...2 t/m ³	above 2 t/m ³
400	$e^{w\alpha}[1.08S_1+0.033 q_b(L_1+(L_{34}+L_{56})\cos\beta+32.3(L_{56}-L_{34})\sin\beta+L_{78}/e^{w\alpha})+0.65(L_1+L_{34}+3.08(L_{56}+L_{78}/e^{w\alpha}))+q_m(L_{56}(0.03\cos\beta+\sin\beta)+0.03L_{78}/e^{w\alpha})]$	$e^{w\alpha}[1.08S_1+0.033 q_b(L_1+(L_{34}+L_{56})\cos\beta+32.3(L_{56}-L_{34})\sin\beta+L_{78}/e^{w\alpha})+0.7(L_1+L_{34}+3.06(L_{56}+L_{78}/e^{w\alpha}))+q_m(L_{56}(0.03\cos\beta+\sin\beta)+0.03L_{78}/e^{w\alpha})]$	$e^{w\alpha}[1.08S_1+0.033 q_b(L_1+(L_{34}+L_{56})\cos\beta+32.3(L_{56}-L_{34})\sin\beta+L_{78}/e^{w\alpha})+0.75(L_1+L_{34}+3.08(L_{56}+L_{78}/e^{w\alpha}))+q_m(L_{56}(0.03\cos\beta+\sin\beta)+0.03L_{78}/e^{w\alpha})]$
500	$e^{w\alpha}[1.08S_1+0.033 q_b(L_1+(L_{34}+L_{56})\cos\beta+32.3(L_{56}-L_{34})\sin\beta+L_{78}/e^{w\alpha})+0.81(L_1+L_{34}+2.82(L_{56}+L_{78}/e^{w\alpha}))+q_m(L_{56}(0.03\cos\beta+\sin\beta)+0.03L_{78}/e^{w\alpha})]$	$e^{w\alpha}[1.08S_1+0.033 q_b(L_1+(L_{34}+L_{56})\cos\beta+32.3(L_{56}-L_{34})\sin\beta+L_{78}/e^{w\alpha})+0.87(L_1+L_{34}+2.84(L_{56}+L_{78}/e^{w\alpha}))+q_m(L_{56}(0.03\cos\beta+\sin\beta)+0.03L_{78}/e^{w\alpha})]$	$e^{w\alpha}[1.08S_1+0.033 q_b(L_1+(L_{34}+L_{56})\cos\beta+32.3(L_{56}-L_{34})\sin\beta+L_{78}/e^{w\alpha})+0.94(L_1+L_{34}+2.82(L_{56}+L_{78}/e^{w\alpha}))+q_m(L_{56}(0.03\cos\beta+\sin\beta)+0.03L_{78}/e^{w\alpha})]$
650	$e^{w\alpha}[1.08S_1+0.033 q_b(L_1+(L_{34}+L_{56})\cos\beta+32.3(L_{56}-L_{34})\sin\beta+L_{78}/e^{w\alpha})+1.23(L_1+L_{34}+2.18(L_{56}+L_{78}/e^{w\alpha}))+q_m(L_{56}(0.03\cos\beta+\sin\beta)+0.03L_{78}/e^{w\alpha})]$	$e^{w\alpha}[1.08S_1+0.033 q_b(L_1+(L_{34}+L_{56})\cos\beta+32.3(L_{56}-L_{34})\sin\beta+L_{78}/e^{w\alpha})+1.31(L_1+L_{34}+2.2(L_{56}+L_{78}/e^{w\alpha}))+q_m(L_{56}(0.03\cos\beta+\sin\beta)+0.03L_{78}/e^{w\alpha})]$	$e^{w\alpha}[1.08S_1+0.033 q_b(L_1+(L_{34}+L_{56})\cos\beta+32.3(L_{56}-L_{34})\sin\beta+L_{78}/e^{w\alpha})+1.43(L_1+L_{34}+2.2(L_{56}+L_{78}/e^{w\alpha}))+q_m(L_{56}(0.03\cos\beta+\sin\beta)+0.03L_{78}/e^{w\alpha})]$
800	$e^{w\alpha}[1.08S_1+0.033 q_b(L_1+(L_{34}+L_{56})\cos\beta+32.3(L_{56}-L_{34})\sin\beta+L_{78}/e^{w\alpha})+2.15(L_1+L_{34}+2.2(L_{56}+L_{78}/e^{w\alpha}))+q_m(L_{56}(0.03\cos\beta+\sin\beta)+0.03L_{78}/e^{w\alpha})]$	$e^{w\alpha}[1.08S_1+0.033 q_b(L_1+(L_{34}+L_{56})\cos\beta+32.3(L_{56}-L_{34})\sin\beta+L_{78}/e^{w\alpha})+2.31(L_1+L_{34}+2.2(L_{56}+L_{78}/e^{w\alpha}))+q_m(L_{56}(0.03\cos\beta+\sin\beta)+0.03L_{78}/e^{w\alpha})]$	$e^{w\alpha}[1.08S_1+0.033 q_b(L_1+(L_{34}+L_{56})\cos\beta+32.3(L_{56}-L_{34})\sin\beta+L_{78}/e^{w\alpha})+2.51(L_1+L_{34}+2.2(L_{56}+L_{78}/e^{w\alpha}))+q_m(L_{56}(0.03\cos\beta+\sin\beta)+0.03L_{78}/e^{w\alpha})]$
1 000	$e^{w\alpha}[1.08S_1+0.033 q_b(L_1+(L_{34}+L_{56})\cos\beta+32.3(L_{56}-L_{34})\sin\beta+L_{78}/e^{w\alpha})+2.75(L_1+L_{34}+2.1(L_{56}+L_{78}/e^{w\alpha}))+q_m(L_{56}(0.03\cos\beta+\sin\beta)+0.03L_{78}/e^{w\alpha})]$	$e^{w\alpha}[1.08S_1+0.033 q_b(L_1+(L_{34}+L_{56})\cos\beta+32.3(L_{56}-L_{34})\sin\beta+L_{78}/e^{w\alpha})+2.98(L_1+L_{34}+2.1(L_{56}+L_{78}/e^{w\alpha}))+q_m(L_{56}(0.03\cos\beta+\sin\beta)+0.03L_{78}/e^{w\alpha})]$	$e^{w\alpha}[1.08S_1+0.033 q_b(L_1+(L_{34}+L_{56})\cos\beta+32.3(L_{56}-L_{34})\sin\beta+L_{78}/e^{w\alpha})+3.25(L_1+L_{34}+2.1(L_{56}+L_{78}/e^{w\alpha}))+q_m(L_{56}(0.03\cos\beta+\sin\beta)+0.03L_{78}/e^{w\alpha})]$
1 200	$e^{w\alpha}[1.08S_1+0.033 q_b(L_1+(L_{34}+L_{56})\cos\beta+32.3(L_{56}-L_{34})\sin\beta+L_{78}/e^{w\alpha})+3.13(L_1+L_{34}+2.14(L_{56}+L_{78}/e^{w\alpha}))+q_m(L_{56}(0.03\cos\beta+\sin\beta)+0.03L_{78}/e^{w\alpha})]$	$e^{w\alpha}[1.08S_1+0.033 q_b(L_1+(L_{34}+L_{56})\cos\beta+32.3(L_{56}-L_{34})\sin\beta+L_{78}/e^{w\alpha})+3.39(L_1+L_{34}+2.14(L_{56}+L_{78}/e^{w\alpha}))+q_m(L_{56}(0.03\cos\beta+\sin\beta)+0.03L_{78}/e^{w\alpha})]$	$e^{w\alpha}[1.08S_1+0.033 q_b(L_1+(L_{34}+L_{56})\cos\beta+32.3(L_{56}-L_{34})\sin\beta+L_{78}/e^{w\alpha})+3.7(L_1+L_{34}+2.14(L_{56}+L_{78}/e^{w\alpha}))+q_m(L_{56}(0.03\cos\beta+\sin\beta)+0.03L_{78}/e^{w\alpha})]$

Findings

For convenience of further research we depict the dependencies of the table 15 in the following form:

$$S_8 = 1.08e^{w\alpha}S_1 + F_{B,\rho}(q_b, L_1, L_{34}, L_{56}, L_{78}, \beta, q_m(E)).$$

Solving the system of equations for the limiting state, in which there is no pulley slipping, we get:

НЕТРАДИЦІЙНІ ВИДИ ТРАНСПОРТУ. МАШИНИ ТА МЕХАНІЗМИ

$$S_8 = e^{\mu\gamma} S_1;$$

$$S_8 = 1.08e^{w\alpha} S_1 + F_{B,p}(q_b, L_1, L_{34}, L_{56}, L_{78}, \beta, q_m(E)). \quad (22)$$

Now equating the right parts of expressions (22), we get:

$$e^{\mu\gamma} S_1 = 1.08e^{w\alpha} S_1 + F_{B,p}(q_b, L_1, L_{34}, L_{56}, L_{78}, \beta, q_m(E)).$$

Using algebraic manipulations we obtain:

$$S_1 = \frac{F_{B,p}(q_b, L_1, L_{34}, L_{56}, L_{78}, \beta, q_m(E))}{(e^{\mu\gamma} - 1.08e^{w\alpha})}; \quad (23)$$

$$S_8 = e^{\mu\gamma} \frac{F_{B,p}(q_b, L_1, L_{34}, L_{56}, L_{78}, \beta, q_m(E))}{(e^{\mu\gamma} - 1.08e^{w\alpha})}. \quad (24)$$

The pulling effort considering the drive pulley rotation resistance is determined by the formula

$$F_o = S_8 - S_1 + (k' - 1)(S_8 + S_1), \quad (25)$$

where $k' = 1.08$ – drive pulley rotation resistance coefficient.

Substituting the expressions (23) and (24) into the formula (25) we get:

$$F_o = (1.08e^{\mu\gamma} - 0.92) \times \frac{F_{B,p}(q_b, L_1, L_{34}, L_{56}, L_{78}, \beta, q_m(E))}{(e^{\mu\gamma} - 1.08e^{w\alpha})}.$$

The belt conveyor drive is more often designed with cylindrical double reduction gear. The kinematic diagram of the drive is shown in Fig. 2.

Rated motor power is calculated by the formula

$$P_p = F_o v / 1000 \eta, \quad (26)$$

where F_o should be substituted in Newton; v – in meters per second; η – drive efficiency factor.

The drive efficiency factor is determined by the formula:

$$\eta = \eta_r \eta_c, \quad (27)$$

where $\eta_r = 0.96$ – reduction gear efficiency factor; $\eta_c = 0.98$ – coupling efficiency factor.

Thus

$$\eta = \eta_r \eta_c = 0.96 \cdot 0.98 = 0.94.$$

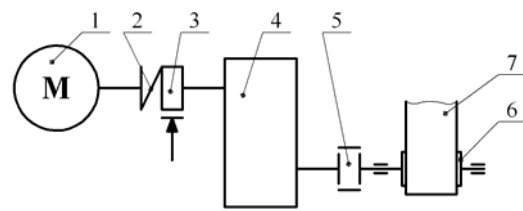

Fig. 2. Belt conveyor drive diagram:
1 – motor; 2 – elastic coupling; 3 – brakes;
4 – reduction gear; 5 – gear coupling;
6 – drive pulley; 7 – belt

The installed motor power (kW) is calculated by the formula

$$P_o = n_i P_r, \quad (28)$$

where $n_i = 1.1 \dots 1.2$ – power reserve factor.

Choosing $n_i = 1.2$ we determine the installed motor power by the formula:

$$P_i = \frac{F_o v}{833.3 \eta}. \quad (29)$$

Dependencies for the motor power value by belt width and load density are shown in Table 16.

Table 16

Calculated drive power

Belt width, mm	P_i at load density ρ , N/m		
	up to 1 t/m ³	1...2 t/m ³	above 2 t/m ³
400	$[v(1.08e^{\mu\gamma} - 0.92)e^{w\alpha}/833.3\eta(e^{\mu\gamma} - 1.08e^{w\alpha})][0.033 q_b(L_1 + (L_{34} + L_{56})\cos\beta + 32.3(L_{56} - L_{34})\sin\beta + L_{78}/e^{w\alpha}) + 0.65(L_1 + L_{34} + 3.08(L_{56} + L_{78}/e^{w\alpha})) + q_m(L_{56}(0.03\cos\beta + \sin\beta) + 0.03L_{78}/e^{w\alpha})]$	$[v(1.08e^{\mu\gamma} - 0.92)e^{w\alpha}/833.3\eta(e^{\mu\gamma} - 1.08e^{w\alpha})][0.033 q_b(L_1 + (L_{34} + L_{56})\cos\beta + 32.3(L_{56} - L_{34})\sin\beta + L_{78}/e^{w\alpha}) + 0.7(L_1 + L_{34} + 3.06(L_{56} + L_{78}/e^{w\alpha})) + q_m(L_{56}(0.03\cos\beta + \sin\beta) + 0.03L_{78}/e^{w\alpha})]$	$[v(1.08e^{\mu\gamma} - 0.92)e^{w\alpha}/833.3\eta(e^{\mu\gamma} - 1.08e^{w\alpha})][0.033 q_b(L_1 + (L_{34} + L_{56})\cos\beta + 32.3(L_{56} - L_{34})\sin\beta + L_{78}/e^{w\alpha}) + 0.75(L_1 + L_{34} + 3.08(L_{56} + L_{78}/e^{w\alpha})) + q_m(L_{56}(0.03\cos\beta + \sin\beta) + 0.03L_{78}/e^{w\alpha})]$

Belt width, mm	P_i at load density ρ , N/m		
	up to 1 t/m ³	1...2 t/m ³	above 2 t/m ³
500	$[\nu(1.08e^{\mu\gamma}-0.92)e^{w\alpha}/833.3\eta(e^{\mu\gamma}-1.08e^{w\alpha})][0.033q_b(L_1+(L_{34}+L_{56})\cos\beta+32.3(L_{56}-L_{34})\sin\beta+L_{78}/e^{w\alpha})+0.81(L_1+L_{34}+2.82(L_{56}+L_{78}/e^{w\alpha}))+q_m(L_{56}(0.03\cos\beta+\sin\beta)+0.03L_{78}/e^{w\alpha})]$	$[\nu(1.08e^{\mu\gamma}-0.92)e^{w\alpha}/833.3\eta(e^{\mu\gamma}-1.08e^{w\alpha})][0.033q_b(L_1+(L_{34}+L_{56})\cos\beta+32.3(L_{56}-L_{34})\sin\beta+L_{78}/e^{w\alpha})+0.87(L_1+L_{34}+2.84(L_{56}+L_{78}/e^{w\alpha}))+q_m(L_{56}(0.03\cos\beta+\sin\beta)+0.03L_{78}/e^{w\alpha})]$	$[\nu(1.08e^{\mu\gamma}-0.92)e^{w\alpha}/833.3\eta(e^{\mu\gamma}-1.08e^{w\alpha})][0.033q_b(L_1+(L_{34}+L_{56})\cos\beta+32.3(L_{56}-L_{34})\sin\beta+L_{78}/e^{w\alpha})+0.94(L_1+L_{34}+2.82(L_{56}+L_{78}/e^{w\alpha}))+q_m(L_{56}(0.03\cos\beta+\sin\beta)+0.03L_{78}/e^{w\alpha})]$
650	$[\nu(1.08e^{\mu\gamma}-0.92)e^{w\alpha}/833.3\eta(e^{\mu\gamma}-1.08e^{w\alpha})][0.033q_b(L_1+(L_{34}+L_{56})\cos\beta+32.3(L_{56}-L_{34})\sin\beta+L_{78}/e^{w\alpha})+1.23(L_1+L_{34}+2.18(L_{56}+L_{78}/e^{w\alpha}))+q_m(L_{56}(0.03\cos\beta+\sin\beta)+0.03L_{78}/e^{w\alpha})]$	$[\nu(1.08e^{\mu\gamma}-0.92)e^{w\alpha}/833.3\eta(e^{\mu\gamma}-1.08e^{w\alpha})][0.033q_b(L_1+(L_{34}+L_{56})\cos\beta+32.3(L_{56}-L_{34})\sin\beta+L_{78}/e^{w\alpha})+1.31(L_1+L_{34}+2.2(L_{56}+L_{78}/e^{w\alpha}))+q_m(L_{56}(0.03\cos\beta+\sin\beta)+0.03L_{78}/e^{w\alpha})]$	$[\nu(1.08e^{\mu\gamma}-0.92)e^{w\alpha}/833.3\eta(e^{\mu\gamma}-1.08e^{w\alpha})][0.033q_b(L_1+(L_{34}+L_{56})\cos\beta+32.3(L_{56}-L_{34})\sin\beta+L_{78}/e^{w\alpha})+1.43(L_1+L_{34}+2.2(L_{56}+L_{78}/e^{w\alpha}))+q_m(L_{56}(0.03\cos\beta+\sin\beta)+0.03L_{78}/e^{w\alpha})]$
800	$[\nu(1.08e^{\mu\gamma}-0.92)e^{w\alpha}/833.3\eta(e^{\mu\gamma}-1.08e^{w\alpha})][0.033q_b(L_1+(L_{34}+L_{56})\cos\beta+32.3(L_{56}-L_{34})\sin\beta+L_{78}/e^{w\alpha})+2.15(L_1+L_{34}+2.2(L_{56}+L_{78}/e^{w\alpha}))+q_m(L_{56}(0.03\cos\beta+\sin\beta)+0.03L_{78}/e^{w\alpha})]$	$[\nu(1.08e^{\mu\gamma}-0.92)e^{w\alpha}/833.3\eta(e^{\mu\gamma}-1.08e^{w\alpha})][0.033q_b(L_1+(L_{34}+L_{56})\cos\beta+32.3(L_{56}-L_{34})\sin\beta+L_{78}/e^{w\alpha})+2.31(L_1+L_{34}+2.2(L_{56}+L_{78}/e^{w\alpha}))+q_m(L_{56}(0.03\cos\beta+\sin\beta)+0.03L_{78}/e^{w\alpha})]$	$[\nu(1.08e^{\mu\gamma}-0.92)e^{w\alpha}/833.3\eta(e^{\mu\gamma}-1.08e^{w\alpha})][0.033q_b(L_1+(L_{34}+L_{56})\cos\beta+32.3(L_{56}-L_{34})\sin\beta+L_{78}/e^{w\alpha})+2.51(L_1+L_{34}+2.2(L_{56}+L_{78}/e^{w\alpha}))+q_m(L_{56}(0.03\cos\beta+\sin\beta)+0.03L_{78}/e^{w\alpha})]$
1 000	$[\nu(1.08e^{\mu\gamma}-0.92)e^{w\alpha}/833.3\eta(e^{\mu\gamma}-1.08e^{w\alpha})][0.033q_b(L_1+(L_{34}+L_{56})\cos\beta+32.3(L_{56}-L_{34})\sin\beta+L_{78}/e^{w\alpha})+2.75(L_1+L_{34}+2.1(L_{56}+L_{78}/e^{w\alpha}))+q_m(L_{56}(0.03\cos\beta+\sin\beta)+0.03L_{78}/e^{w\alpha})]$	$[\nu(1.08e^{\mu\gamma}-0.92)e^{w\alpha}/833.3\eta(e^{\mu\gamma}-1.08e^{w\alpha})][0.033q_b(L_1+(L_{34}+L_{56})\cos\beta+32.3(L_{56}-L_{34})\sin\beta+L_{78}/e^{w\alpha})+2.98(L_1+L_{34}+2.1(L_{56}+L_{78}/e^{w\alpha}))+q_m(L_{56}(0.03\cos\beta+\sin\beta)+0.03L_{78}/e^{w\alpha})]$	$[\nu(1.08e^{\mu\gamma}-0.92)e^{w\alpha}/833.3\eta(e^{\mu\gamma}-1.08e^{w\alpha})][0.033q_b(L_1+(L_{34}+L_{56})\cos\beta+32.3(L_{56}-L_{34})\sin\beta+L_{78}/e^{w\alpha})+3.25(L_1+L_{34}+2.1(L_{56}+L_{78}/e^{w\alpha}))+q_m(L_{56}(0.03\cos\beta+\sin\beta)+0.03L_{78}/e^{w\alpha})]$
<i>l</i>	2	3	4
1 200	$[\nu(1.08e^{\mu\gamma}-0.92)e^{w\alpha}/833.3\eta(e^{\mu\gamma}-1.08e^{w\alpha})][0.033q_b(L_1+(L_{34}+L_{56})\cos\beta+32.3(L_{56}-L_{34})\sin\beta+L_{78}/e^{w\alpha})+3.13(L_1+L_{34}+2.14(L_{56}+L_{78}/e^{w\alpha}))+q_m(L_{56}(0.03\cos\beta+\sin\beta)+0.03L_{78}/e^{w\alpha})]$	$[\nu(1.08e^{\mu\gamma}-0.92)e^{w\alpha}/833.3\eta(e^{\mu\gamma}-1.08e^{w\alpha})][0.033q_b(L_1+(L_{34}+L_{56})\cos\beta+32.3(L_{56}-L_{34})\sin\beta+L_{78}/e^{w\alpha})+3.39(L_1+L_{34}+2.14(L_{56}+L_{78}/e^{w\alpha}))+q_m(L_{56}(0.03\cos\beta+\sin\beta)+0.03L_{78}/e^{w\alpha})]$	$[\nu(1.08e^{\mu\gamma}-0.92)e^{w\alpha}/833.3\eta(e^{\mu\gamma}-1.08e^{w\alpha})][0.033q_b(L_1+(L_{34}+L_{56})\cos\beta+32.3(L_{56}-L_{34})\sin\beta+L_{78}/e^{w\alpha})+3.7(L_1+L_{34}+2.14(L_{56}+L_{78}/e^{w\alpha}))+q_m(L_{56}(0.03\cos\beta+\sin\beta)+0.03L_{78}/e^{w\alpha})]$

Originality and practical value

We developed parametric dependence of drive power of the belt conveyer with sloping and horizontal areas on type of load, design efficiency, geometrical dimensions and path configuration, operation conditions that takes into account standard

dimensions and parameters of belts, idlers and pulleys.

Use of the built dependences gives an opportunity of relatively rapid determination of approximate value of the drive power for the belt conveyers of considered design, as well as it allows qual-

НЕТРАДИЦІЙНІ ВИДИ ТРАНСПОРТУ. МАШИНИ ТА МЕХАНІЗМИ

ity selection of its basic elements at specific design characteristics and requirements.

The proposed dependences can be used for determination of general impact of the design efficiency and other parameters on the conveyor drive power.

Conclusions

For belt conveyors with sloping and horizontal areas we built parametric dependence of drive power on the design parameters: type of load, design efficiency, geometrical dimensions and path configuration, operation conditions. Such dependences allow calculating the required drive power value, taking into account the type and the physical and mechanical properties of load, the lifting height value, the transport length and design efficiency, using only one formula, chosen depending on design characteristics.

LIST OF REFERENCE LINKS

1. Александров, М. П. Подъемно-транспортные машины : учебник / М. П. Александров. – Москва : Высш. шк., 2000. – 522 с.
2. Богомаз, В. М. Аналіз впливу проектних характеристик елеватору на параметри його приводу / В. М. Богомаз // Наука та прогрес транспорту. – 2015. – № 3 (57). – С. 162–175. doi: 10.15802/stp2015/46076.
3. Богомаз, В. М. Дослідження впливу проектної продуктивності елеватору на потужність його приводу / В. М. Богомаз, К. Ц. Главацький, О. А. Мазур // Наука та прогрес транспорту. – 2015. – № 2 (56). – С. 189–206. doi: 10.15802/stp2015/42178.
4. Зенков, Р. Л. Машины непрерывного транспорта : учебник / Р. Л. Зенков, И. И. Ивашков, Л. Н. Колобов. – Москва : Машиностроение, 1987. – 432 с.
5. Иванченко, Ф. К. Подъемно-транспортные машины : учебник / Ф. К. Иванченко. – Киев : Вища шк., 1993. – 413 с.
6. Катрюк, И. С. Машины непрерывного транспорта. Конструкции, проектирование и эксплуатация: учеб. пособие / И. С. Катрюк, Е. В. Мусяченко. – Красноярск : ИПЦ КГТУ, 2006. – 266 с.
7. Кузьмин, А. В. Справочник по расчетам механизмов подъемно-транспортных машин : учебн. пособие / А. В. Кузьмин. – Минск : Вышэйшая школа, 1983. – 350 с.
8. Підйомно-транспортні машини: розрахунки підймальних і транспортувальних машин : підручник / В. С. Бондарев, О. І. Дубинець, М. П. Колісник [та ін.]. – Київ : Вища шк., 2009. – 734 с.
9. Расчет и проектирование транспортнх средств непрерывного действия : научное пособие для вузов / А. И. Барышев, В. А. Будишевский, А. А. Сулима, А. М. Ткачук. – Донецк : Норд-Пресс, 2005. – 689 с.
10. Ромакин, Н. Е. Машины непрерывного транспорта : учебн. пособие / Н. Е. Ромакин. – Москва : Академия, 2008. – 432 с.
11. Jamaludin, J. Development of a self-tuning fuzzy logic controller for intelligent control of elevator systems / J. Jamaludin, N. A. Rahim, W. P. Hew // Engineering Applications of Artificial Intelligence. – 2009. – Vol. 22. – Iss. 8. – P. 1167–1178. doi: 10.1016/j.engappai.2009.04.006.
12. Kim, C. S. Nonlinear robust control of a hydraulic elevator: experiment-based modeling and two-stage Lyapunov redesign / C. S. Kim, K. S. Hong, M. K. Kim // Control Engineering Practice. – 2005. – Vol. 13. – Iss. 6. – P. 789–803. doi: 10.1016/j.conengprac.2004.09.003.
13. Strakosch, G. R. The Vertical Transportation Handbook / G. R. Strakosch, R. S. Caporale. – New York : John Wiley&Sons, 2010. – 610 p. doi: 10.1002/9780470949818.

В. М. БОГОМАЗ^{1*}

^{1*}Каф. «Військова підготовка спеціалістів Державної спеціальної служби транспорту», Дніпропетровський національний університет залізничного транспорту імені академіка В. Лазаряна, вул. Лазаряна, 2, Дніпропетровськ, Україна, 49010, тел. +38 (056) 793 19 09, ел. пошта wbogomas@i.ua, ORCID 0000-0001-5913-2671

ДОСЛІДЖЕННЯ ЗАЛЕЖНОСТІ ПОТУЖНОСТІ ПРИВОДУ СТРІЧКОВОГО КОНВЕЄРУ ВІД ЙОГО ПРОЕКТНИХ ПАРАМЕТРІВ

Мета. Привід є одним із основних елементів стрічкових конвеєрів. Для визначення потужності приводу необхідно провести розрахунки за стандартними методиками, які викладені в сучасній технічній літературі. Для таких розрахунків потрібно витратити достатньо багато часу. Основними проектними параметрами

НЕТРАДИЦІЙНІ ВИДИ ТРАНСПОРТУ. МАШИНИ ТА МЕХАНІЗМИ

стрічкового транспортера є: тип вантажу, проектна продуктивність, геометричні розміри та конфігурація траси, умови роботи. В статті необхідно побудувати параметричну залежність потужності приводу стрічкового конвеєру від проектних параметрів, яка враховувала б стандартні розміри і параметри стрічок, роликкоопор та барабанів. **Методика.** Розглядається стрічковий конвеєр із двома ділянками: похилою та горизонтальною. Використовуючи методику тягового розрахунку способом обходу по контуру стрічкових конвеєрів, побудовано параметричні залежності сил натягу в характерних точках траси конвеєру від типу вантажу, проектної продуктивності, геометричних розмірів та конфігурації траси конвеєру, умов роботи. **Результати.** Для стрічкових конвеєрів розглянутого типу з врахуванням стандартних розмірів стрічки та відповідними припущеннями щодо типу роликкоопор та барабанів побудовано параметричні залежності потужності приводу від типу вантажу, проектної продуктивності, геометричних розмірів і конфігурації траси конвеєру, умов роботи. **Наукова новизна.** Вперше побудована параметрична залежність потужності приводу стрічкових конвеєрів із двома ділянками (похилою та горизонтальною) від типу вантажу, проектної продуктивності, геометричних розмірів та конфігурації траси конвеєру, умов роботи. Вона враховує стандартні розміри та параметри стрічок, роликкоопор і барабанів. **Практична значимість.** Використання побудованих залежностей потужності приводу стрічкових конвеєрів із похилою та горизонтальною ділянками від проектних параметрів дає можливість відносно швидкого визначення приблизного значення потужності приводу на стадії проектування. Також можливим є виконання якісного підбору його основних елементів при конкретних проектних характеристиках та вимогах. Запропоновані залежності можуть бути використані для визначення загального характеру залежності потужності приводу від проектної продуктивності.

Ключові слова: конвеєр; стрічка; привід; потужність; продуктивність; вантаж

В. Н. БОГОМАЗ^{1*}

^{1*}Каф. «Военная подготовка специалистов Государственной специальной службы транспорта», Днепропетровский национальный университет железнодорожного транспорта имени академика В. Лазаряна, ул. Лазаряна, 2, Днепропетровск, Украина, 49010, тел. +38 (056) 793 19 09, эл. почта wbogomas@i.ua, ORCID 0000-0001-5913-2671

ИССЛЕДОВАНИЕ ЗАВИСИМОСТИ МОЩНОСТИ ПРИВОДА ЛЕНТОЧНОГО КОНВЕЙЕРА ОТ ЕГО ПРОЕКТНЫХ ПАРАМЕТРОВ

Цель. Привод является одним из основных элементов ленточных конвейеров. Для определения мощности привода необходимо провести расчеты по стандартным методикам, которые изложены в современной технической литературе. Для таких расчетов нужно потратить достаточно много времени. Основными проектными параметрами ленточных транспортеров являются: тип груза, проектная производительность, геометрические размеры и конфигурация трассы, условия работы. В статье необходимо построить параметрическую зависимость мощности привода ленточного конвейера от его проектных параметров, которая учитывала б стандартные размеры и параметры лент, роликкоопор и барабанов. **Методика.** Рассматривается ленточный конвейер с двумя участками: наклонным и горизонтальным. Используя методику тягового расчета способом обхода по контуру ленточных конвейеров, построены параметрические зависимости сил натяжения в характерных точках трассы конвейера от типа груза, проектной производительности, геометрических размеров и конфигурации трассы, условий работы. **Результаты.** Для ленточных конвейеров рассмотренного типа с учетом стандартных размеров ленты и соответствующими предположениями относительно типов роликкоопор и барабанов построены параметрические зависимости мощности привода от типа груза, проектной производительности, геометрических размеров и конфигурации трассы, условий работы. **Научная новизна.** Впервые построена параметрическая зависимость мощности привода ленточных конвейеров с двумя участками (наклонной и горизонтальной) от типа груза, проектной производительности, геометрических размеров и конфигурации трассы, условий работы. Она учитывает стандартные размеры и параметры ленты, роликкоопор и барабанов. **Практическая значимость.** Использование построенных зависимостей мощности привода ленточных конвейеров с наклонным и горизонтальным участками дает возможность относительно быстрого определения приблизительного значения мощности привода на стадии проектирования. Также возможным является выполнение качественного подбора его основных элементов при конкретных проектных характеристиках и требованиях. Предложенные зависимости могут быть использованы для определения общего характера зависимости мощности привода от проектной производительности.

Ключевые слова: конвейер; лента; привод; мощность; производительность; груз

REFERENCES

1. Aleksandrov M.P. *Podemno-transportnyye mashiny* [Lifting and transport machines]. Moscow, Vysshaya shkola Publ., 2000. 522 p.
2. Bohomaz V.M. Analiz vplyvu proektnykh kharakterystyk elevatoru na parametry yoho pryvodu [Influence analyses of designed characteristics of the elevator to the parameters of its drive]. *Nauka ta prohres transportu – Science and Transport Progress*, 2015, no. 3 (57), pp. 162-175. doi: 10.15802/stp2015/46076.
3. Bohomaz V.M., Hlavatskyi K.Ts., Mazur O.A. Doslidzhennia vplyvu proektnoi produktyvnosti elevatoru na potuzhnist yoho pryvodu [Research of influencing of project descriptions of elevator on parameters of its drive]. *Nauka ta prohres transportu – Science and Transport Progress*, 2015, no. 2 (56), pp. 189-206. doi: 10.15802/stp2015/42178.
4. Zenkov R.L., Ivashkov I.I., Kolobov L.N. *Mashiny nepreryvnogo transporta* [Machines of continuous transport]. Moscow, Mashinostroeniye Publ., 1987. 432 p.
5. Ivanchenko F.K. *Pidiomno-transportni mashyny* [Lifting and transport machines]. Kyiv, Vyshcha shkola Publ., 1993. 413 p.
6. Katryuk I.S., Musiyachenko Ye.V. *Mashiny nepreryvnogo transporta. Konstruktsii, proyektirovaniye i ekspluatatsiya* [Machines of continuous transport. Construction, design and operation]. Krasnoyarsk, IPTs KGTU Publ., 2006. 266 p.
7. Kuzmin, A.V. *Spravochnik po raschetam mekhanizmov podemno-transportnykh mashin* [Manual of calculation mechanisms of lifting and transport machines]. Minsk, Vysheyshaya shkola Publ., 1983. 350 p.
8. Bondariyev V.S., Dubynets O.I., Kolisnyk M.P. *Pidiomno-transportni mashyny: rozrakhunky pidiimalnykh i transportovalnykh mashyn* [Lifting and transport machines: calculations of hoisting and conveying machines]. Kyiv, Vyshcha shkola Publ., 2009. 734 p.
9. Baryshev A. I., Budishevskiy V. A., Sulima A. A., Tkachuk A. M. *Raschet i proyektirovaniye transportnykh sredstv nepreryvnogo deystviya* [Calculation and design of continuous action vehicles]. Donetsk, Nord-Press Publ., 2005. 689 p.
10. Romakin N.Ye. *Mashiny nepreryvnogo transporta* [Machines of continuous transport]. Moscow, Akademiya Publ., 2008. 432 p.
11. Jamaludin J., Rahim N.A., Hew W.P. Development of a self-tuning fuzzy logic controller for intelligent control of elevator systems. *Engineering Applications of Artificial Intelligence*, 2009, vol. 22, issue 8, pp. 1167-1178. doi: 10.1016/j.engappai.2009.04.006.
12. Kim C.S., Hong K.S., Kim M.K. Nonlinear robust control of a hydraulic elevator: experiment-based modeling and two-stage Lyapunov redesign. *Control Engineering Practice*, 2005, vol. 13, issue 6, pp. 789-803. doi: 10.1016/j.conengprac.2004.09.003.
13. Strakosch G.R., Caporale R.S. *The Vertical Transportation Handbook*. New York, John Wiley&Sons Publ., 2010. 610 p. doi: 10.1002/9780470949818.

Prof. S. V. Raksha, Sc. Tech. (Ukraine); Assos. Prof. S. V. Shatov, Sc. Tech. (Ukraine) recommended this article to be published

Accessed: Nov., 20. 2015

Received: Jan., 15. 2016