

УДК 621.318

**EMF ATTRACTION OF THIN-WALLED SHEET METAL**

**Yu. Batygin, Professor, Doctor of Technical Science,  
A. Hnatov, Professor, Doctor of Technical Science,  
E. Chaplygin, Assistant Professor, Candidate of Technical Sciences, KhNAHU**

***Abstract.** The work is dedicated to EMF attraction processes which can deform both ferromagnetic and non-ferromagnetic sheet metal materials using low frequency discharges. The analytical models of both tooling configurations are based upon the solution of Maxwell equations in axially symmetrical formulation. The concept of attraction in this inductor system is based upon inducing currents flowing in the same directions in the screen and in the sheet metal blank.*

***Key words:** electroforming, metal forming, tool*

**МАГНІТНО-ІМПУЛЬСНЕ ПРИТЯГАННЯ ТОНКОСТІННИХ ЛІСТОВИХ МЕТАЛІВ**

**Ю.В. Батигін, професор, д.т.н., А.В. Гнатів, професор, д.т.н.,  
Є.О. Чаплигін, доцент, к.т.н., ХНАДУ**

***Анотація.** Робота присвячена магнітно-імпульсному притяганню, за допомогою якого при досить низьких робочих частотах можливе деформування як ферромагнітних, так і неферромагнітних металів. Застосовані в розрахунках аналітичні моделі засновані на розв'язку рівнянь Максвелла в ідеалізації аксіальної симетрії.*

***Ключові слова:** електроформовка, обробка металів, інструмент.*

**МАГНІТНО-ИМПУЛЬСНОЕ ПРИТЯЖЕНИЕ ТОНКОСТЕННЫХ ЛИСТОВЫХ МЕТАЛЛОВ**

**Ю.В. Батыгин, профессор, д.т.н., А.В. Гнатив, профессор, д.т.н.,  
Е.А. Чаплыгин, доцент, к.т.н., ХНАДУ**

***Аннотация.** Работа посвящена магнитно-импульсному притяжению, с помощью которого при достаточно низких рабочих частотах возможно деформирование как ферромагнитных, так и неферромагнитных металлов. Применяемые в расчётах аналитические модели основаны на решении уравнений Максвелла в идеализации аксиальной симметрии.*

***Ключевые слова:** электроформовка, обработка металлов, инструмент.*

**Introduction**

Electromagnetic forming, crimping, welding and cutting are well known in industry since 1960s. A comprehensive review of these technologies was published by Psyk et al. (2011) [1]. All these processes are based upon repelling Lorentz forces between the EMF coil and the conductive blank. In such a configuration, the coil and the tool (the

forming die or the mandrel to which the blank is welded or crimped, or the shearing die with sharp cutting edges) are positioned from the opposite sides of the blank. In addition to such repelling processes, another configuration of EMF processes is possible where the blank is attracted to the coil. The objective of this paper is to introduce a new manufacturing process of the thin-walled metal sheets attraction using low frequency discharges.

## EMF attraction process for ferromagnetic materials

The objective of this part is to describe the concept, provide a simplified mathematical model predicting attracting electromagnetic forces for ferromagnetic materials and illustrate this concept with experimental results supporting the major conclusions of the analytical study.

### Analytical model of the process and numerical examples

The initial experiments described in details in Batygin (2013) [2] illustrated that the effect of attraction is possible only for the low frequencies, when

$$\omega \ll \frac{1}{\mu \cdot \gamma \cdot d^2} \quad (1)$$

where  $\omega = 2\pi \cdot f$ ,  $f$  – is the working frequency,  $\mu$  – is the permeability of metal,  $\gamma$  – is the electric conductivity of sheet metal, and  $d$  – is the sheet metal thickness.

The interaction between a single turn inductor and a ferromagnetic sheet metal blank is being analyzed. The schematic of the process is shown in Fig. 1.

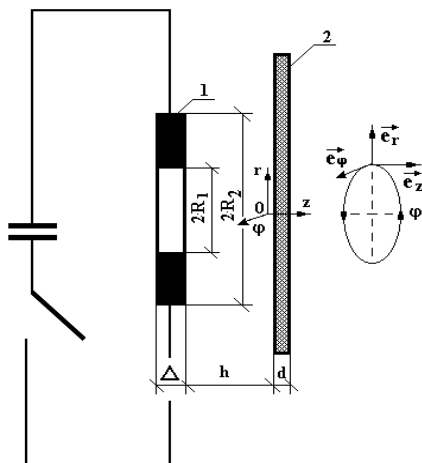

Fig. 1. The schematic of the single turn inductor (1) interacting with ferromagnetic sheet metal blank (2), where  $\vec{e}_r, \vec{e}_\phi, \vec{e}_z$  – are the unit vectors in the cylindrical coordinate system

The following assumptions were made in order to simplify the mathematical model of the process:

1) the single turn inductor is sufficiently thin (its

thickness  $\rightarrow 0$ ) and “transparent” for the acting fields, so its metal has no effect on considered electromagnetic processes;

2) the process is considered quasi stationary according to the criterion  $\omega/c \cdot \ell \ll 1$ , where  $\omega$  – is the cyclic frequency of the process,  $c$  – is the light velocity for vacuum,  $\ell$  – is the greatest typical dimension of the system under consideration;

3) the system has an axial symmetry, so  $\partial/\partial\phi=0$  ( $\phi$  – is the polar angle);

4) the sheet metal blank is sufficiently thin, and its radial dimension is sufficiently large, so  $d/R_{1,2} \ll 1$  and  $\omega \cdot \tau \ll 1$  ( $\tau = \mu_1 \cdot \gamma \cdot d^2$ ,  $\gamma, d$  – are conductivity and thickness of the sheet metal blank,  $R_{1,2}$  – are the internal and external radii of the inductor);

5) the permeability of the sheet metal is constant and is equal to  $\mu_1$ ,  $\mu_1 = \mu_0 \mu_r$ ,  $\mu_0$  and  $\mu_r$  – are the vacuum permeability and the relative permeability of metal accordingly;

6) reproduction of the mutual inductance of tool coil and work piece is neglected;

7) the sheet metal's motion is not taken into account;

8) nonlinear behavior of ferromagnetic saturation is neglected considering an average value of magnetic permeability;

9) variability of conductivity as a consequence of temperature rise due to Joule heating as well as due to magnetization is neglected;

10) reversion of magnetization is not taken into account.

The Maxwell equations were solved with usage of the Laplace and Fourier-Bessel integral transforms with zero initial conditions for the non-trivial components of the electromagnetic field vector ( $E_\phi \neq 0, H_{r,z} \neq 0$ ) in limits of the formulated assumptions.

The detailed discussion of the mathematical procedures was provided by Batygin et al (2013). The resulting parameter is an integrated average force applied to the circular area of the sheet metal blank. It was calculated through integration of pressure through the radial coordinate and time and then averaging its value

through the time period of the acting field. This averaged force is analyzed as a function of the discharge frequency to provide the recommendations for the pulse generator.

The numerical calculations were performed for the single turn coil –  $R_1=0,025\text{m}$ ,  $R_2=0,03\text{m}$ ; insulating gap –  $h=0,0005\text{m}$ . The sheet metal blank:  $\gamma=0,4\cdot 10^7$  1/(Ohm·m),  $\mu_r\approx 2,5$ ,  $d=0,00075\text{m}$ . The amplitude of the discharge current was  $I_m=50\text{kA}$ , and the frequency was  $f=2\dots 8\text{kHz}$ . The results of calculations are presented in Figure 2.

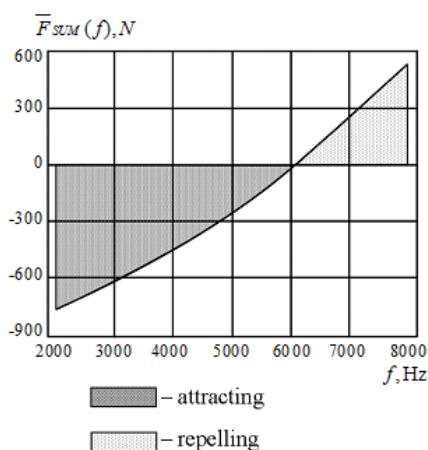

Fig. 2. An average integral force acting on the thin-walled ferromagnetic sheet as a function of the frequency of acting field

According to Fig. 2, reducing the discharge frequency below the some critical value of  $\sim 6$  kHz leads to change of the direction of the integrated force: below the marked critical frequency  $\sim 6$  kHz thin-walled sheet ferromagnetic metal is being attracted to the inductor: above the frequency of  $\sim 6$  kHz, the sheet metal blank is being repelled. For the frequency range  $f \in [2,8]$  kHz the applied electromagnetic force acting on the sheet ferromagnetic metal was changing its direction: for  $f > 6$  kHz repelling took place, but for  $f < 6$  kHz attraction was displayed.

### Experimental validation

Experimental validation of the proposed concept was done with the intent of practical application of the proposed process to dent removal from automotive exterior panels manufactured from steel. The experimental setup is shown in Figure 3.

The single turn massive inductor with the working zone diameter of 40 mm was connected to the pulse generator via current pulse transformer

with the coefficient of transformation of five. The discharge frequency was measured as 1,9 kHz. The amplitude of electric current flowing through the coil was 38 kA.

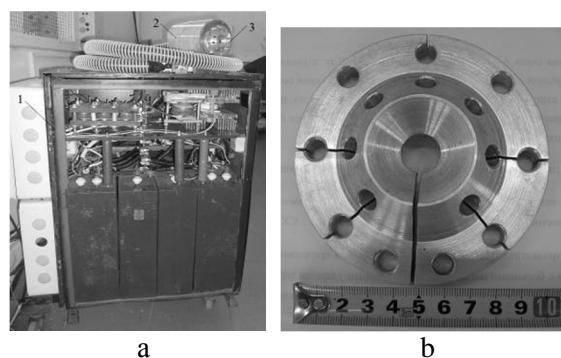

Fig. 3. The experimental setup: a – the laboratory equipment for EMF attraction processes with maximum charging voltage of 2kV and accumulated energy of 2kJ: 1 – pulse generator; 2 – pulsed current transformer; 3 – single turn inductor; b – the single turn massive inductor

The DDQ (Deep Drawing Quality) flat sheet steel samples 0,8 mm thick (the steel DDQ yield strength is equaled to 180 MPa, stainless steel – 350...300 MPa) were positioned next to the single turn coil. The sample was insulated from the coil with  $\sim 1$  mm layer of insulation. Initially flat samples were bulged by attraction inside the working zone of the single turn coil. The bulge was axisymmetric and had the maximum height of 1,5 mm at the axis of symmetry of the coil.

After the initial bulge was produced on a flat blank using the described process of electromagnetic attraction, it was flipped over, and dent removal process was physically simulated by pulling the bulge back with the electromagnetic attraction process. The experimental sample is shown on Figure 4. The dent was successfully removed which confirmed the suggested concept.

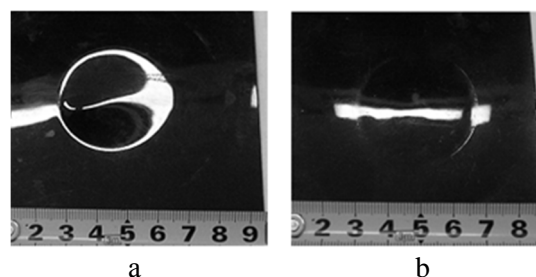

Fig. 4. The experimental DDQ steel sample: a – after producing the dent; b – after removing the dent

### EMF attraction process for non-magnetic materials

The objective of this part is to describe the concept and provide a simplified mathematical model of pulsed electromagnetic attraction of non-magnetic materials in the “Inductor System with an Attracting Screen” as well as to illustrate the experimental results supporting the suggested concept and the major conclusions of the analytical study.

#### Theoretical analysis, numerical calculations

The schematic of the proposed process of sheet metal attraction is employing an Inductor System with Attracting Screen (ISAS) shown in Fig. 5.

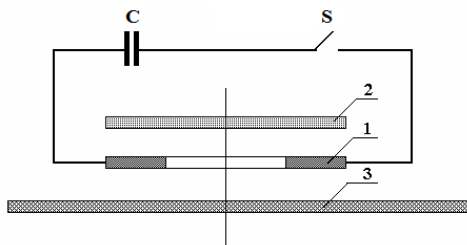

Fig. 5. Schematic of ISAS: 1 – is the single-turn inductor; 2 – is the auxiliary attracting screen; 3 – is the sheet metal blank; C – is the bank of capacitors; S – is the switch of the discharge circuit

When the switch (S) gets into a closed position by a special ignition circuit not shown in Figure 5, the preliminary charged capacity storage (C) starts discharging through the single-turn inductor (1) with the internal radius  $R_1$ , the external radius  $R_2$  and rather small thickness. The discharge current is inducing the unidirectional eddy currents in the attractive screen (2) and sheet metal blank (3) both made of similar non-ferromagnetic sheet material. If the screen (2) is rigidly mounted on an insulated plate of the tool, it remains stationary during the discharge process while the sheet metal blank (3) will be attracted to the working surface of the inductor (1) in accordance to Ampere law. The suggested system is working in the low frequency range specified by inequality (1).

The analytical solution of this problem is described by Batygin et al. (2014) [3].

The numerical calculations were performed for an experimental inductor system where single-turn

inductors with different internal and external diameters. The screen and the sheet metal blank are identical thin-walled sheets with the thickness  $d=0,001$  m from the non-magnetic metal with the specific conductivity  $\gamma=0,4 \cdot 10^7$  1/(Ohm·m). They are located symmetrically relatively to the plane of the single-turn inductor at a distance  $h=1,5$  mm from each other. In the conducted experiments, the electric current amplitude in the inductor was  $I_m=40$  kA, and the frequency of the pulse was  $f=2$  kHz. The relative damping coefficient was calculated as the damping coefficient divided by the cyclic frequency and was equal to  $\delta_0=0,3$ . The predicted distribution of the attracting specific forces is illustrated in Figure 6. The integrated attracting force is illustrated in Figure 7 as a function of the radius of the circular window of the coil.

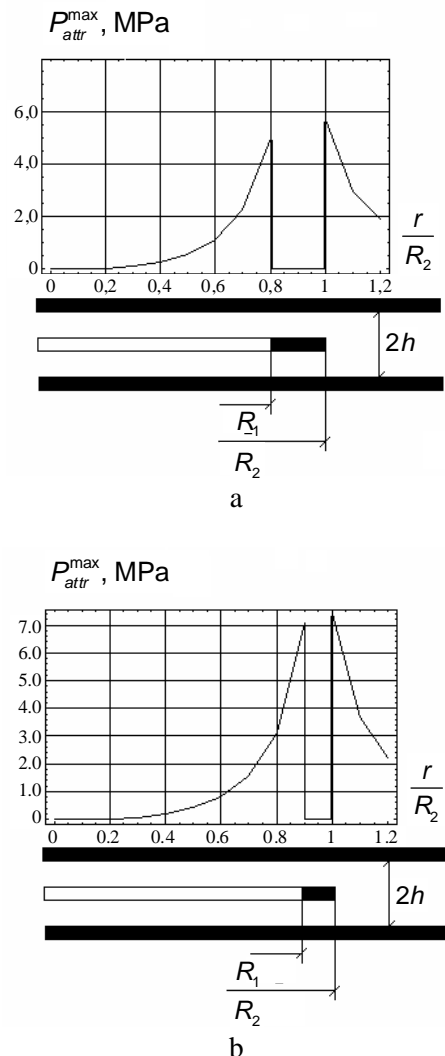

Fig. 6. The distribution of the density of attraction forces at the time moment when they have their maximum values for the following combinations of the dimensions of the inductor: a –  $R_1=0,035$  m,  $R_2=1/0,8 \cdot R_1$ ; b –  $R_1=0,035$  m,  $R_2=1/0,9 \cdot R_1$

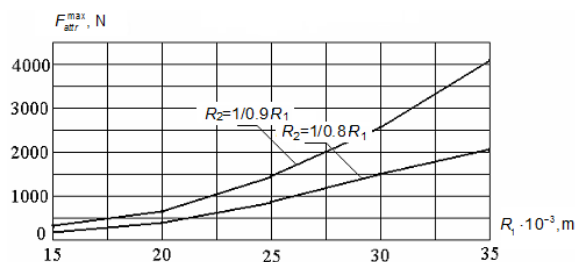

Fig. 7. The effect of the inner radius of the inductor on the attracting force between the screen and the blank

The main results of this analysis can be formulated the following way: in the suggested ISAS, substantial amplitudes of the attraction forces are achievable: their densities can reach  $\sim 7,0 \dots 8,0$  MPa (Fig. 6) and their integral values can reach  $\sim 4000$  N (Fig. 7) for the coil with 35 mm radius of the inner window.

### Experimental validation

The laboratory version of the ISAS is shown in Fig. 8 a.

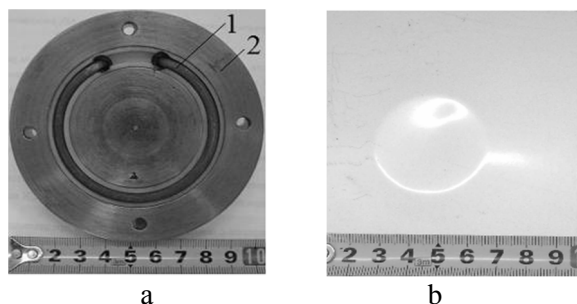

Fig. 8. The laboratory version of the ISAS (a, 1 – is the inductor, 2 – is the screen) and result of the EMF attraction of the part of the stainless steel sheet (b)

Structurally, the thin flat screen is fulfilled from 1mm sheet of stainless steel.

The material had the following properties: yield stress was 310 MPa; specific conductivity was  $0,4 \cdot 10^7$  1/Ohm·m. The sheet metal screen was rigidly mounted on a surface of a massive dielectric plate preventing deformation of the screen. A sin-

gle-turn inductor with the inner diameter of 60 mm was mounted on top of the screen and was covered by an insulating plate 1 mm thick. The blank was made from the same 1 mm stainless steel sheet. The working zone of the investigated inductor system is the round opening with diameter 45 mm in the insulating plate on the inductor. The part of the sheet metal blank positioned against the opening in the insulating plate was expected to be deformed by the EMF attraction forces. The amplitude of the electric current running through the coil was  $J_m = 39,2$  kA, and the frequency of the discharge was  $f = 2$  kHz. The relative damping coefficient was  $\delta_0 = 0,3$ . After eight discharges, the sheet metal blank was attracted into the inner opening of the working zone: the dent had a diameter of 40 mm and a the depth of 1mm formed on the surface of sheet metal blank (Fig. 8b).

### Conclusions

The conducted theoretical analysis and experiments confirmed the proposed concepts of the inductor systems for ferromagnetic and non-ferromagnetic blank materials. The tools for both versions of the EMF attraction require the low frequency discharge when repulsion caused by the Lorentz forces is negligible compared to the attraction forces.

### References

1. Psyk, V.; Risch, D.; Kinsey, B.L.; Tekkayaa, A.E.; Kleiner, M.: Electromagnetic forming – A review. *Journal of Materials Processing Technology* 211, 2011, p.787-829.
2. Batygin Y. V.; Golovashchenko S.F.; Gnatov A.V.: Pulsed Electromagnetic Attraction of Sheet Metals – Fundamentals and Perspective Applications. *Journal of Materials Processing Technologies*. 213, 2013, p. 444-452.
3. Batygin Y. V.; Golovashchenko S.F.; Gnatov A.V.: Pulsed Electromagnetic Attraction of non-magnetic Sheet Metals. Applications. *Journal of Materials Processing Technologies*. 214, 2014, p. 390-401.